



Government of Western Australia
Department of Mines, Industry Regulation and Safety



Dear industry stakeholder

Product Safety Recall – Faulty Swimming Pool Gate Latch Assemblies

Building and Energy is highlighting the product safety recall of some faulty gate latch assemblies used in glass pool fencing and gates.

Building and Energy understands that these latches, made by Aristo Glass Products Pty Ltd, were available between 1 August 2021 and 3 March 2022 from a number of glass fencing retailers and installers.

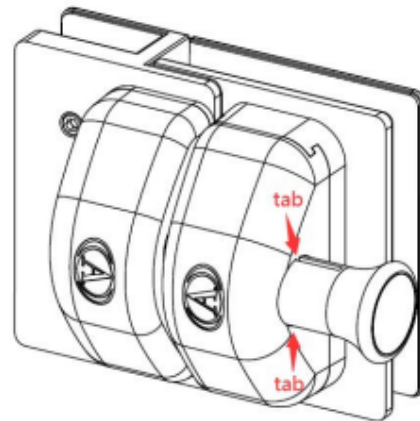

Identification

The gate latches have a polymer plastic cover with an 'A' logo, and have guide tabs on two sides of the engagement pin. The following models are part of the recall:

- SLP2011 - 180° Glass to Glass Latch
- SLP2012 - Glass to Wall Latch
- SLP2013 - 90° Outswing Glass to Glass Latch
- SLP2014 - 90° Inswing Glass to Glass Latch
- SLP2015 - Glass to Round Post Latch
- SLP2007 - 135° Glass to Glass Latch

The problem

The **recall notice** advises that the gate latch guide tabs may break, stopping the engagement pin from retracting and connecting securely with the magnetic keeper. This can result in the gate not latching properly.

If the gate latch does not operate correctly, the gate may remain unlatched. The gate will then be ineffective in restricting children from entering a pool or spa area, posing a drowning risk.

Consumers should ensure the gate is secured until a replacement latch has been installed.

Consumers should contact Aristo Glass Products Pty Ltd on 08 9418 8914 or email admin@aristogroup.com.au for a replacement latch.

More information on the product safety recall can be found at the Product Safety Australia [website](#).

Pool barrier inspectors

It is suggested that local government pool inspectors look out for these types of gate latch assemblies when conducting their regular inspection duties. If an inspector identifies one of these latches, they should advise the property owner and occupier of the issue, and suggest that they keep the gate secure until a replacement gate latch can be installed. It should be noted that even if the gate latch seems to be working properly, consumers should replace the recalled models anyway.

Gates are a high-risk area, and a pivotal point of compliance:

- The [Royal Life Saving Society Western Australia's 10-year analysis of toddler drownings](#) indicates that the majority of young children who drowned in private swimming pools gained access through the pool gate.
- Additionally, an [Ombudsman WA report](#) found that problems with gate latches were the most common reason that swimming pool barriers did not comply with the Building Regulations 2012 on initial inspection.

Building and Energy contact: Martin Roddis 08 6251 1012

Contact us:

Department of Mines, Industry Regulation and Safety
Locked Bag 100, East Perth WA 6892 | T: 6251 1900

be.publications@dmirs.wa.gov.au | www.dmirs.wa.gov.au/building-and-energy

You have received this email because you are licensed
or you have subscribed to industry mail-outs.