

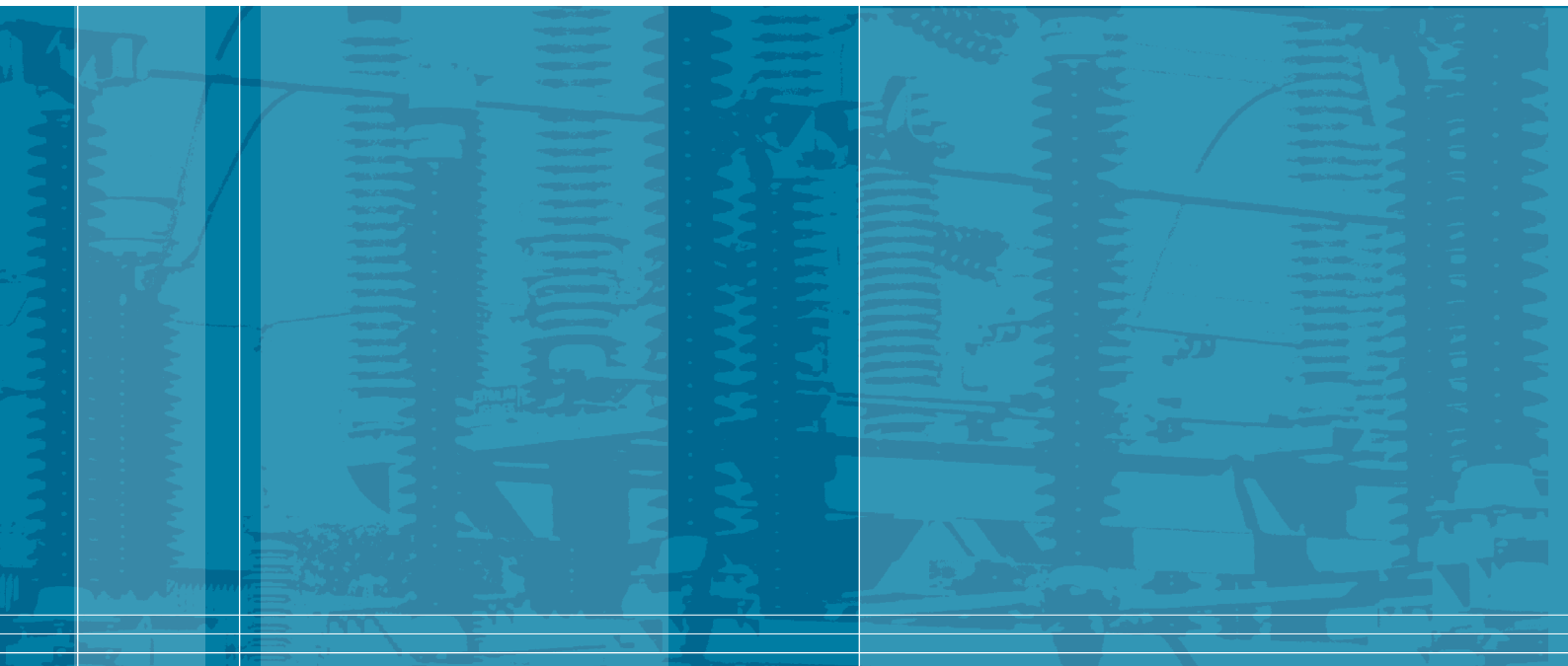

Government of **Western Australia**  
Department of **Commerce**  
*EnergySafety*



# WA Electrical Requirements

Published by the Director of Energy Safety of *EnergySafety* WA  
Under the provisions of the Electricity (Licensing) Regulations 1991

July 2008

## Preface

Energy Safety Division (*EnergySafety*) of the Department of Commerce, following consultations with network operators and electrical contracting industry groups in Western Australia, issued this updated version of the Western Australian Electrical Requirements (WAER).

Electrical installation designs begun after 1 July 2008 must comply with this June 2008 version. Designs started before 1 July 2008, and projects under construction at that date, may comply with the earlier September 2005 version and will be accepted until 31 December 2008. The application of WAER and subsequent amendments is not retrospective.

The publication is based on information in the September 2005 version, revised to reflect the State's electricity industry restructure on 1 April 2006. The latest version also includes more detail concerning high voltage installations and multiple points of supply.

The document provides an authoritative reference for the safe and efficient connection of consumer's installations to electricity networks. Mandatory safety and technical requirements applicable to all networks are set out in Sections 1 to 12. Section 12 requirements are additional to, or override, Australian Standards. These apply also, where relevant, to consumers' electrical installations not connected to a network. Section 13 lists requirements applicable to particular electricity supply networks (or directs the reader to where they may be viewed).

The WAER is made a mandatory guideline under Regulation 49 of the Western Australian *Electricity (Licensing) Regulations 1991*. The WAER should be read with the *Electricity Regulations 1947, Part VIII*, and the *Electricity (Licensing) Regulations 1991*. Both sets of regulations take precedence.

Section 12 lists several mandatory Australian Standards. As a general rule, nothing in those Standards is replicated in the WAER. The reader needs to refer to the Standards.

The requirements within Sections 1 to 12 are mandatory unless the Director of Energy Safety grants a prior written exemption. Failure to comply with a requirement may result in prosecution under the *Electricity (Licensing) Regulations 1991*. It may also cause electricity connection delays.

A review committee assesses the WAER document regularly to ensure it remains up to date. The committee comprises representatives from *EnergySafety*, network operators and the National Electrical Communications Association of WA.

Amendments will be issued as necessary and published in the Energy Bulletin. The latest version of the WAER and Energy Bulletins may be read and downloaded from *EnergySafety's* website (<http://www.energysafety.wa.gov.au>).



**K BOWRON**

Director of Energy Safety

Comments and suggestions on this document may be forwarded to:  
Principal Engineer Electricity Utilisation  
*EnergySafety* WA  
303 Sevenoaks Street, CANNINGTON, Western Australia 6107  
fax (08 9422 5244) or email ([energysafety@commerce.wa.gov.au](mailto:energysafety@commerce.wa.gov.au)).

# Table of Contents

Preface.....	ii
<b>1 Introduction .....</b>	<b>4</b>
<b>2 Definitions.....</b>	<b>5</b>
<b>3 General Requirements.....</b>	<b>9</b>
3.1 Supply Arrangements .....	9
3.2 Earthing System.....	9
3.3 Power Factor.....	9
3.4 Permanently Installed Stand-Alone Generating Sets .....	10
3.5 Loads Affecting Other Customers .....	10
3.6 Point of Supply (Underground) .....	11
3.7 Removal of Existing Overhead Service.....	16
3.8 Labelling .....	16
3.9 Multiple Points of Supply.....	17
<b>4 LV Overhead Network.....</b>	<b>24</b>
4.1 Connection .....	24
4.2 Route & Point of Attachment.....	24
4.3 Crossing an Adjoining Property.....	24
4.4 Aerial Consumers Mains .....	24
4.5 Spans and Clearances.....	24
4.6 Point of Attachment .....	25
4.7 Consumer and Point of Attachment Poles .....	26
<b>5 LV Underground Network.....</b>	<b>27</b>
5.1 Connection .....	27
5.2 Cables and Enclosures .....	27
5.3 Service Connection Devices .....	27
5.4 Building Entry.....	28
5.5 Other Services .....	31
5.6 Network Operator's On-site Substation.....	31
5.7 Contractor Termination of Consumers Mains .....	31

## Table of Contents (continued)

<b>6</b>	<b>Metering and Service Equipment</b> .....	32
6.1	Basic Requirements .....	32
6.2	Responsibilities .....	32
6.3	Location and Accessibility .....	33
6.4	Unsuitable Locations .....	35
6.5	Protection .....	36
6.6	Metering Configurations .....	36
6.7	Neutral Link .....	38
6.8	Service Protection Devices .....	38
6.9	Energisation .....	40
<b>7</b>	<b>High Voltage Installations</b> .....	41
7.1	Design .....	41
7.2	Basic Requirements .....	41
7.3	Consumer's High Voltage Electrical Installation .....	41
7.4	Submission of Proposal .....	42
7.5	Earthing .....	43
<b>8</b>	<b>Special LV Supply Arrangements</b> .....	44
8.1	Standby/Emergency Supply .....	44
8.2	Standby Generators .....	44
8.3	Common Loads .....	46
8.4	Short Term Events .....	46
8.5	Un-metered Supply .....	47
<b>9</b>	<b>Embedded Generators Connected to Networks</b> .....	48
9.1	Basic Requirements .....	48
9.2	Safety .....	49
9.3	Protection, Monitoring and Control .....	49
<b>10</b>	<b>Construction Sites</b> .....	50

## Table of Contents (continued)

<b>11</b>	<b>Emergency Conditions</b> .....	51
11.1	Damaged Installations.....	51
11.2	Emergency Disconnection .....	51
11.3	Defective Main Switch or Boundary Fuse.....	51
11.4	Consumers Mains Failure.....	51
11.5	Mains Connection Box Failure.....	52
11.6	Warning Notices.....	52
12.1	Application of Wiring Rules Part 1 .....	53
<b>12</b>	<b>Additional Requirements</b> .....	53
12.2	Consumers Mains.....	55
12.3	Current-Carrying Capacity of Cables .....	55
12.4	Consumers Mains in Wall Cavities.....	55
12.5	Equi-potential Bonding in Shower Recesses and Bathrooms.....	55
12.6	Earth Electrodes .....	56
12.7	Segregation of Electrical Installations .....	56
12.8	Minimum Cross-sectional Area of Conductors .....	56
12.9	Jointing Consumers Mains.....	56
12.10	Isolated Networks Supplied by Diesel or Gas Power Stations .....	56
12.11	Applicable Standards.....	57
12.12	Part 1 Design and Verification Certificate .....	58
<b>13</b>	<b>Network Operators</b> .....	60
13.1	Introduction.....	60
13.2	Western Power – The Southwest Interconnected System .....	60
13.3	Horizon Power .....	61
13.4	Rio Tinto Iron Ore.....	63
13.5	BHP Billiton Limited.....	65

# 1 Introduction

While the WAER refers to responsibilities of consumers (the owners/operators of electrical installations), in many instances these are carried out by a licensed electrical contractor or other authorised person, under instruction of and on behalf of the consumer.

Upon written application, the Director of Energy Safety may exempt in writing any network operator or other person from complying with a requirement set out in Sections 1 to 12, or to vary the application of any requirements, subject to any conditions the Director stipulates.

As a general rule, the Director will not consider an exemption from the normal requirements set out in this document unless the applicant clearly demonstrates in writing the special circumstances that may justify such an action.

Nothing in Sections 1 to 11 and 13 may be used or interpreted to vary any of the requirements for a consumer installation specified in any of the Australian Standards prescribed in Section 12, unless:

- (a) details of such variation(s) are set out in this document; or
- (b) the relevant Standard has a specific provision for varying the prescribed requirements (for the matter in question), at the discretion of the network operator.

Where it is found that the requirements of this publication have not been followed, any person aware of such a contravention should report their concern(s) to the Director of Energy Safety immediately.

## 2 Definitions

**The Act:** *The Electricity Act 1945*;

**AMR System:** Automated Meter Reading (AMR) system also known as a remote reading system.

**C(b)1:** Guidelines for the Maintenance of Overhead Distribution and Transmission Lines, as published by Energy Networks Australia.

**Connection Point:** That point defined in an access contract or, where there is no specific access contract, the upstream terminals of the consumer's main switch.

**Consumer Pole:** A pole supplied, installed and maintained by the consumer, on the consumer's property, to provide ground clearance for the network operator's overhead service cables (Figure 2.2).

**Consumer Pole (Point of Attachment):** A pole, complying with AS/NZS 3000, supplied, installed and maintained by the consumer, on the consumer's property, used to terminate the network operator's overhead service cable on the consumer's mains (Figure 2.3). A main switchboard enclosure containing a Service Protection Device (SPD) and meter may be mounted on this pole.

**Customer (consumer):** A legal entity to which electricity is sold for the purposes of consumption.

**A1 Consumer Installation:** An assembly of electrical wiring, components and equipment downstream from the point of supply, excluding network operator's metering equipment, and includes all types of assemblies, such as those in domestic residences and commercial, industrial and institutional premises where persons use electricity in appliances and electrical equipment.

**Cyclonic Area:** All of Western Australia's coastline north of Kalbarri and the immediate hinterland within 200 kilometres of the coast.

**Distribution system:** Any apparatus, equipment, plant or buildings used, or to be used, for, or in connection with, the transportation of electricity at nominal voltages of less than 66 kV.

**Director:** The Director of Energy Safety, as defined in the *Energy Coordination Act 1994*.

**Freehold Title Lot:** (Formerly known as green title) A defined portion of land depicted on a plan or diagram for which a separate Crown Grant or Certificate of Title has been or can be issued as defined by the *Planning and Development Act*.

**Load:** The total maximum electrical power demanded by a consumer's installation, measured in Amperes or Watts. This is the maximum demand defined and calculated according to AS/NZS 3000.

**Network operator:** Means a supply authority and any person lawfully operating transmission or distribution works, and service apparatus, but does not include the owner of premises to which electricity is supplied who distributes the electricity to a person occupying part or all of the premises.

**Network:** Includes service apparatus but does not include any other part of a consumer installation.

**Point of Supply:** The location at which the consumers mains are connected to the network operator's supply system.

## 2 Definitions (continued)

**Property boundary:** A surveyed line or border of a freehold title lot.

**Regulations:** Regulations made under the *Electricity Act 1945*, (*Electricity Regulations 1947* and *Electricity (Licensing) Regulations 1991*);

**Retailer:** A body holding a retail licence or an integrated regional licence under the *Electricity Industry Act 2004*.

**Strata Title:** Lots and common property forming part of a strata plan or survey strata plan under the *Strata Title Act 1985*.

**A1 Service apparatus:** Any electrical equipment which is or is capable of being or is intended to be used for the purpose of conveying, measuring, or controlling electricity supplied from any transmission or distribution works to the position on any premises at which delivery of the electricity is, is capable of being, or is intended to be, made to the consumer, and includes any part of the service apparatus, and any other equipment or plant used in conjunction therewith, whether or not the property of a supply authority or network operator;.

**Service Protection Device (SPD):** A fuse, circuit breaker or other device on which the consumers mains are terminated and which limits fault current into a consumer's installation, provides overload protection for the consumers mains and metering equipment and enables the installation to be disconnected from the network operator's supply.

**Small Country Town, Rural, Semi Rural, Major Regional Centre an or Metropolitan region:** As defined by the Western Australian Planning Commission (WAPC).

**Wiring Rules:** The current edition of AS/NZS 3000 as published by Standards Australia.



### Typical Supply Connection Arrangements

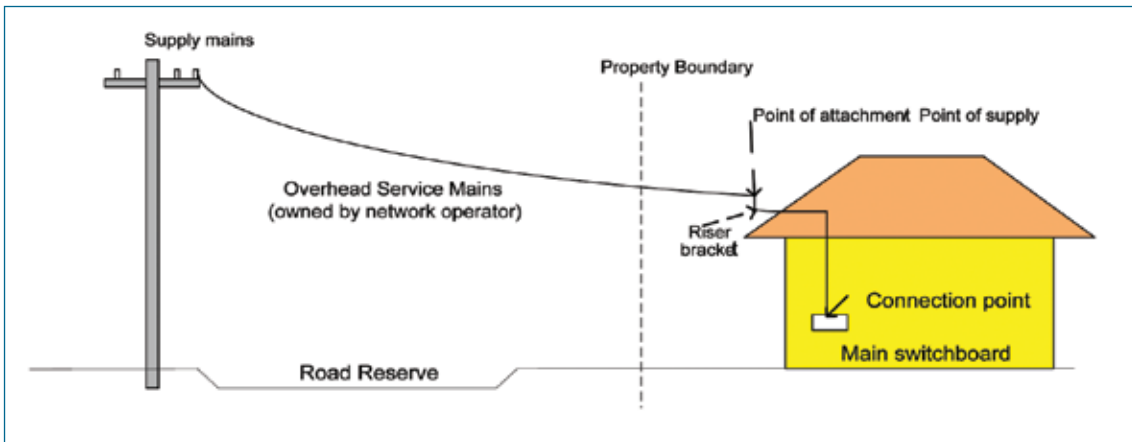

Figure 2.1 Overhead service

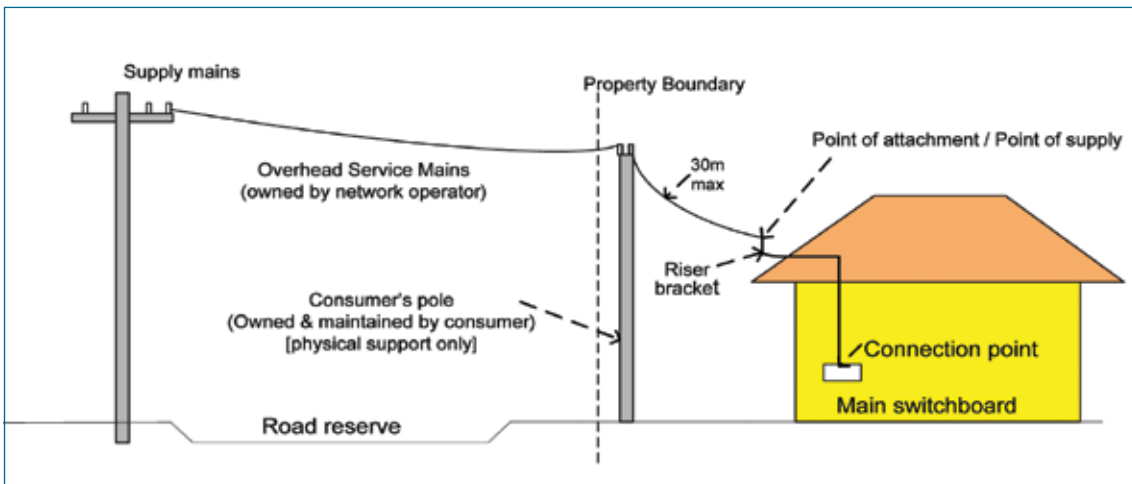

Figure 2.2 Overhead service with consumer pole

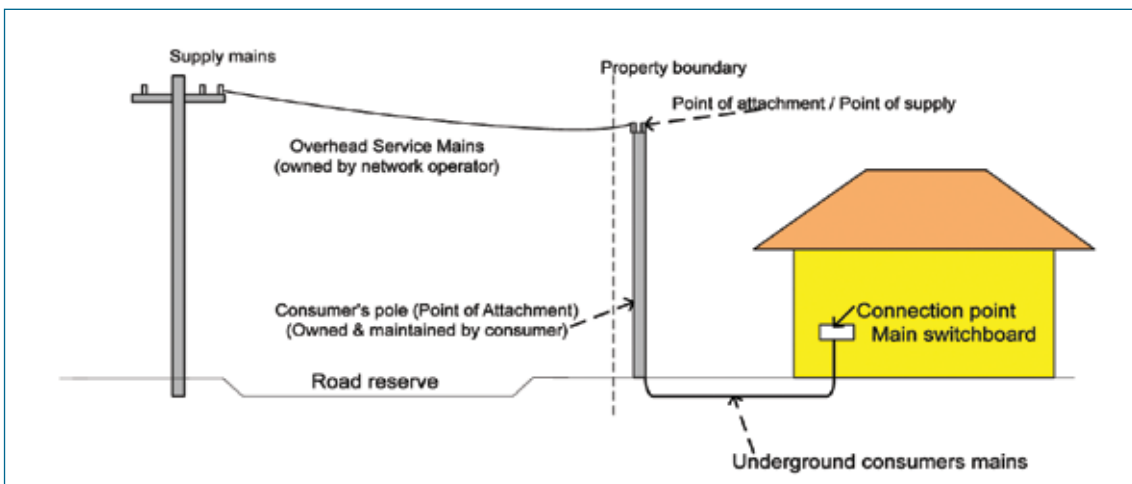

Figure 2.3 Overhead service and underground consumers mains

2 Definitions (continued)

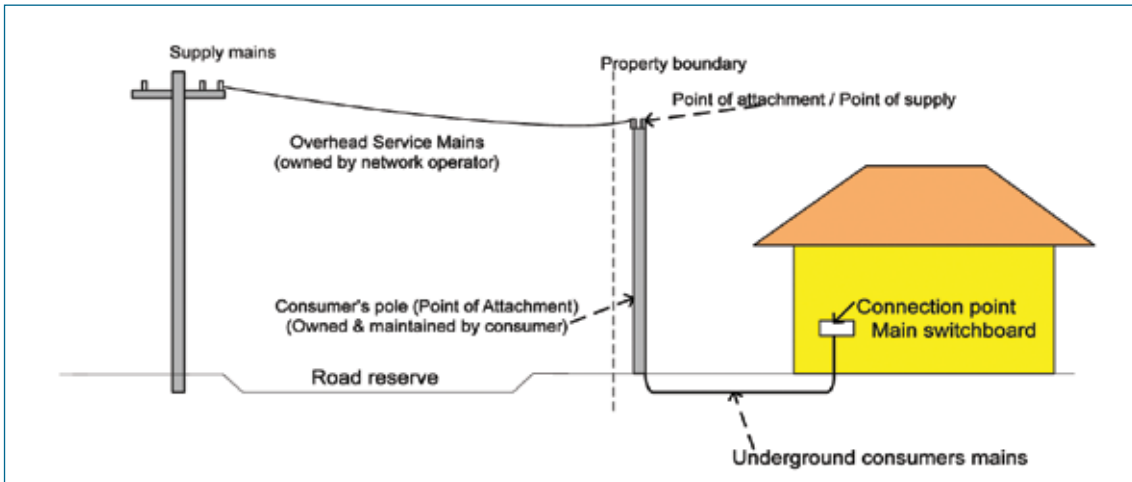

Figure 2.4 Overhead street mains and underground consumers mains (Version 1)

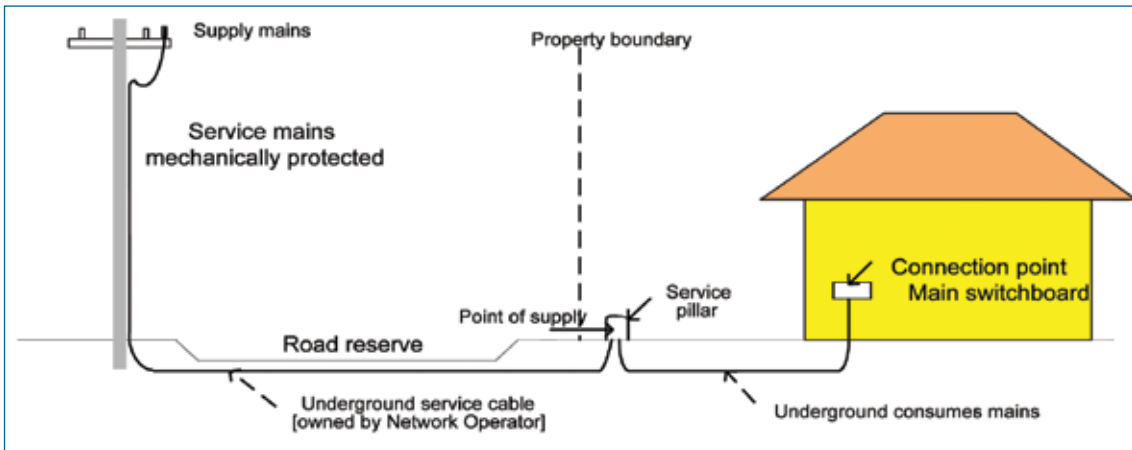

Figure 2.5 Overhead street mains and underground consumers mains (Version 2)

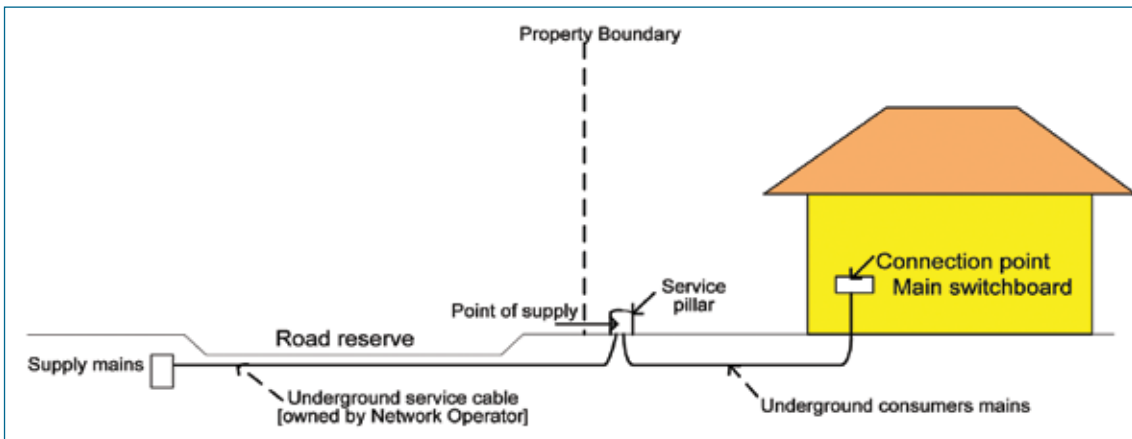

Figure 2.6 Underground service and underground consumers mains

## 3 General Requirements

### 3.1 Supply Arrangements

Supply arrangements for consumers shall comply with this document. However in the case of consumers with specific connection agreements with the network operator, typically large consumers, the requirements may vary.

Consumers or their agent initially must apply to a retailer for supply. The retailer will inform the consumer of the network operator providing the connection.

When a consumer (or representative) applies for a new or expanded electricity supply, the network operator will provide details via an appropriate medium about the method of connection, including:

- voltage
- point of supply
- supply capacity
- fault level
- characteristics of network protection grading
- system of earthing
- any other requirements.

The consumer's installation shall be designed and constructed in accordance with all statutory and network operator requirements.

Consumers must install equipment with fault ratings adequate for the network operator's nominated fault level at the point of supply.

The network operator may nominate a value less than the prescribed maximum fault level for the connection voltage specified in their technical rules. Should the fault level at the point of supply subsequently increase, the consumer shall upgrade the installation's fault-withstand rating to meet the new level.

### 3.2 Earthing System

Unless otherwise approved by the network operator, the earthing system to be used in all low voltage installations shall be the Multiple Earthed Neutral (MEN) system as defined by the Wiring Rules.

The MEN connection is to be located at the consumer's main switchboard unless otherwise approved or directed by the network operator. Other MEN connections for sub-installations may be installed in accordance with the Wiring Rules.

The earthing system used for high voltage installations shall be in accordance with Section 7 of this document.

### 3.3 Power Factor

The consumer, unless exempted by the network operator, shall ensure that the power factor of its installations connected to a distribution network, measured at the point of supply, is not less than 0.8 lagging at the time of the consumer's daily peak demand.

At no time shall the power factor of an installation become leading unless permitted in writing by the network operator.

### 3 General Requirements (continued)

#### 3.4 Permanently Installed Stand-Alone Generating Sets

Where sources of electricity generation are permanently installed in a consumer's installation to provide an independent electricity supply for that installation, the generator installation shall comply with:

- AS/NZS: 3010.1: Electrical installations – generating sets. When the generator is driven by an internal combustion engine set
- AS 4509: Stand alone power systems. For renewable energy power supply systems
- AS/NZS 4777: Grid connection of energy systems via inverters
- AS/NZS 5033: For photo-voltaic systems

#### 3.5 Loads Affecting Other Customers

##### 3.5.1 General

Any equipment causing or which may cause large, rapid changes in electricity demand likely to affect the supply quality experienced by other consumers shall not be connected to a distribution network without appropriate mitigation being implemented.

Equipment shall not cause voltage flicker or voltage step changes exceeding levels specified by the network operator.

The network operator may consider and connect loads outside these parameters following formal application by the consumer. If a consumer operates any equipment the network operator considers does or may interfere with the electricity supply quality to others, the network operator may require the consumer to make appropriate adjustments or alterations to the equipment to remove or sufficiently abate the interference within a specified time period and may disconnect supply if the adjustments or alterations are not carried out within the time specified.

The above requirement applies on initial connection of an installation to a network, and at all times thereafter.

##### 3.5.2 Inrush Current

Unless authorised by the network operator, equipment shall be of a type provided with a suitable current-limiting device so that the maximum inrush current complies with the following:

Maximum Allowable Inrush Currents (A)

##### Single Phase (240v):

Cities and major regional centres: 45A

Other locations (SWIS): 18A (see Section 13.3 for Horizon Power requirements).

##### Three Phase (415v):

All areas: 13A up to 1.5kW

8.6A per kW 1.5-6.0kW

33A plus 3.2A per kW greater than 6.0kW

Inrush current means the peak instantaneous value of current drawn by the equipment when energised. The network operator may consider and connect loads above these limits following formal application by the consumer.

Consumers shall negotiate with the network operator concerning the conditions for connection of any installation with any item of electrical equipment exceeding 75 kW demand.

### 3 General Requirements (continued)

#### 3.5.3 Single Phase appliances

Appliances with a rating exceeding 5kW (20A) (or 13.5kW for ranges, ovens, and hotplates) shall not be connected unless:

- switching arrangements are incorporated preventing the loading of any one switching operation exceeding 20A and imposing a minimum 20mS delay between successive switching operations (on or off)
- or approved by the network operator.

#### 3.6 Point of Supply (Underground)

A network operator's service pillar on a lot is the point of supply for that lot and for the adjacent lot (see Figures 3.6(a) & (b)). Where a pillar is installed on a lot, the premise on that lot must be connected to that pillar.

##### Typical Point of Supply Arrangements

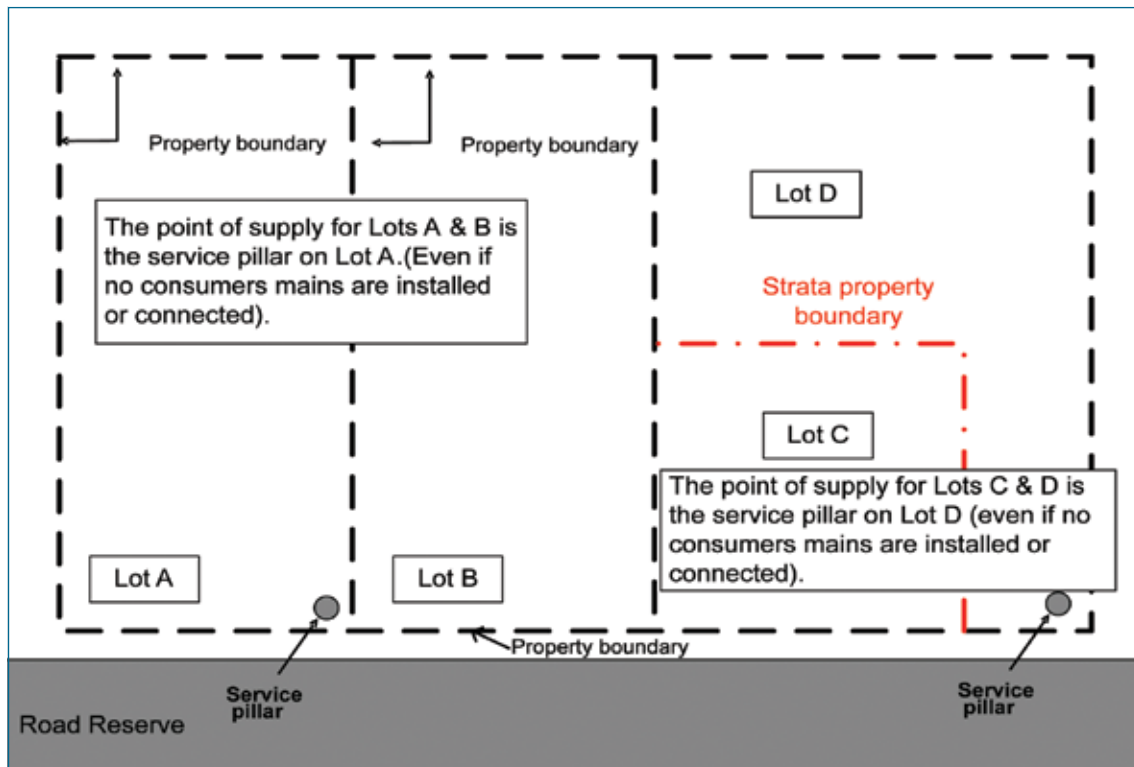

Figure 3.6(a) Example of point of supply

### 3 General Requirements (continued)

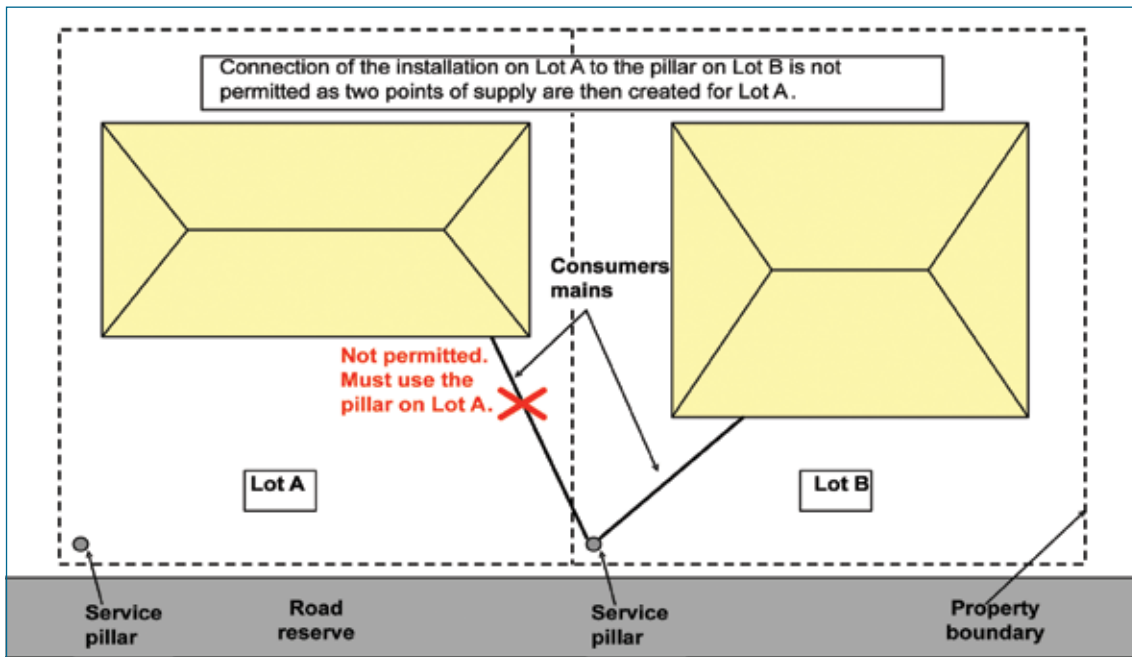

Figure 3.6(b) Example of point of supply

A network operator's transformer or LV kiosk located on a lot or adjacent road reserve or public open space is not a point of supply for a lot unless the consumer mains for the lot are connected to it (Figures 3.6(c) & 3.6(d)).

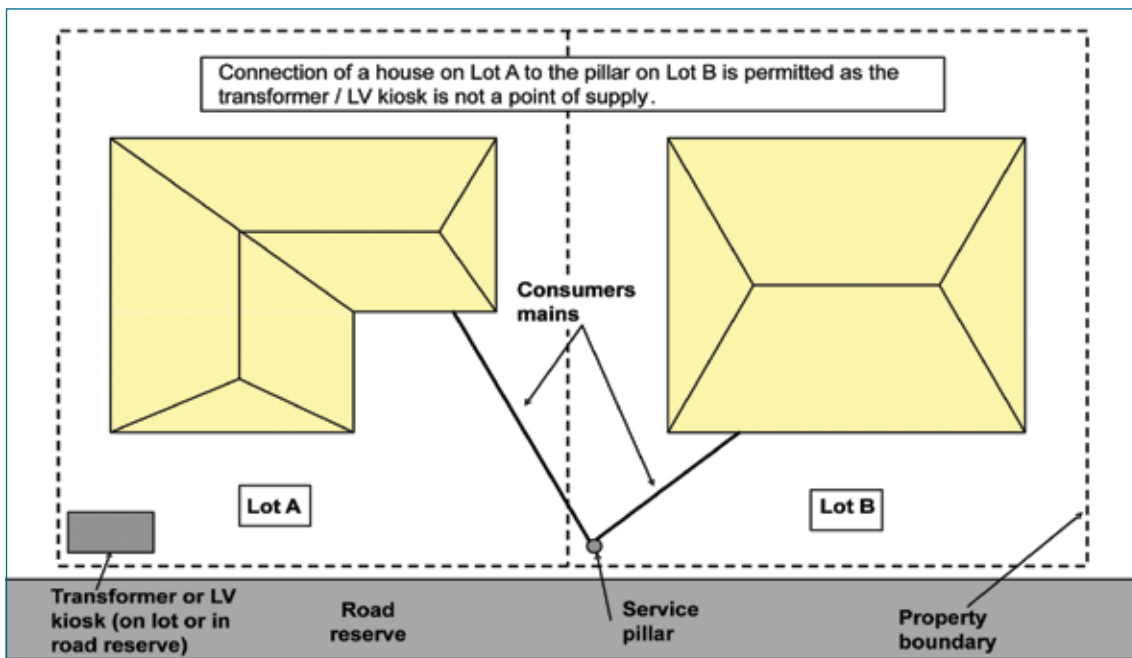

Figure 3.6(c) Example of points of supply

### 3 General Requirements (continued)

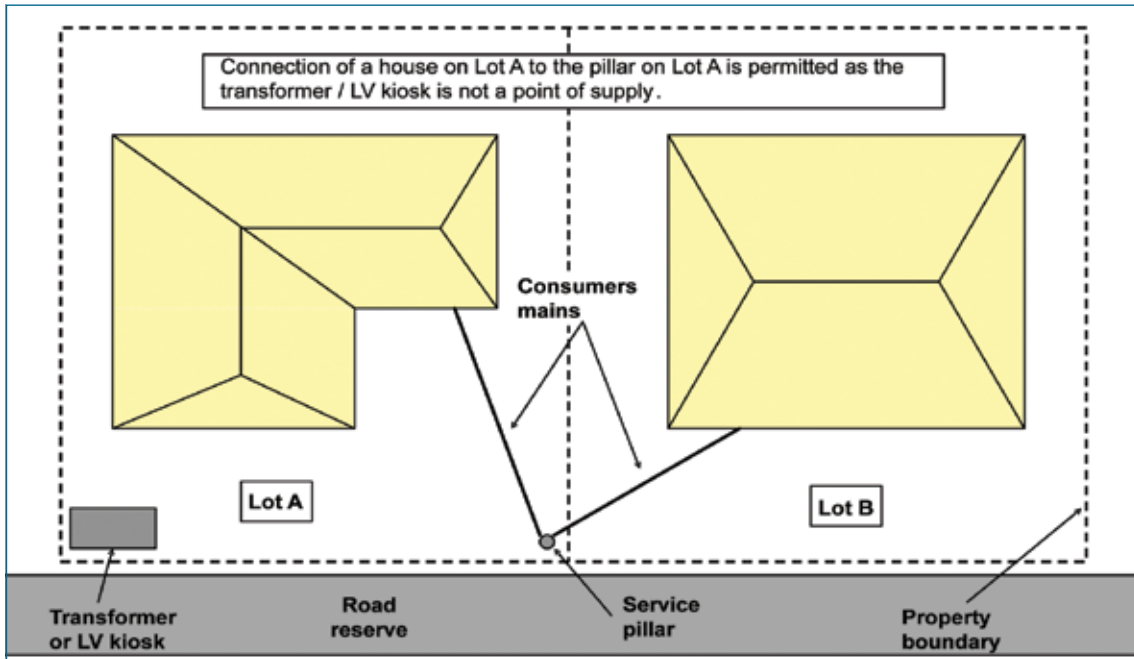
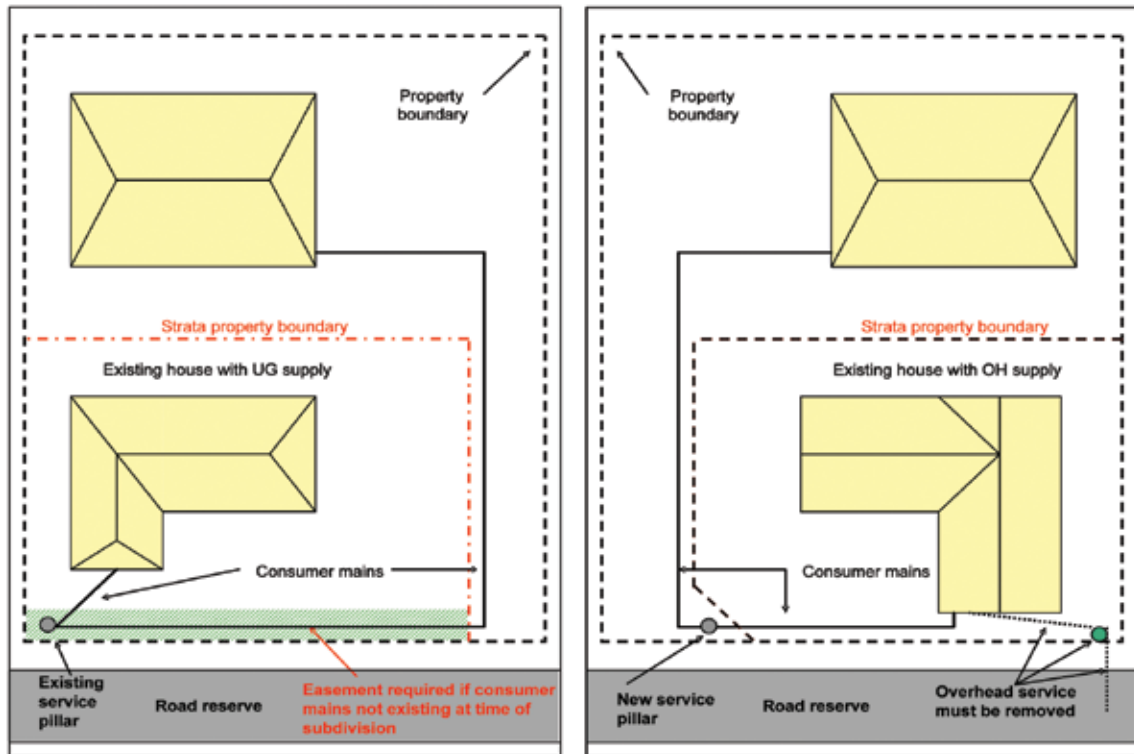

Figure 3.6(d) Example of points of supply

#### Other Acceptable Connections

Some examples of acceptable connection configurations are given in Figures 3.6(e) to 3.6(j).



Figures 3.6 (e & f) Examples of ‘battle-axe’ subdivision with and without easements (Contact Landgate for details of how to create an easement).

### 3 General Requirements (continued)

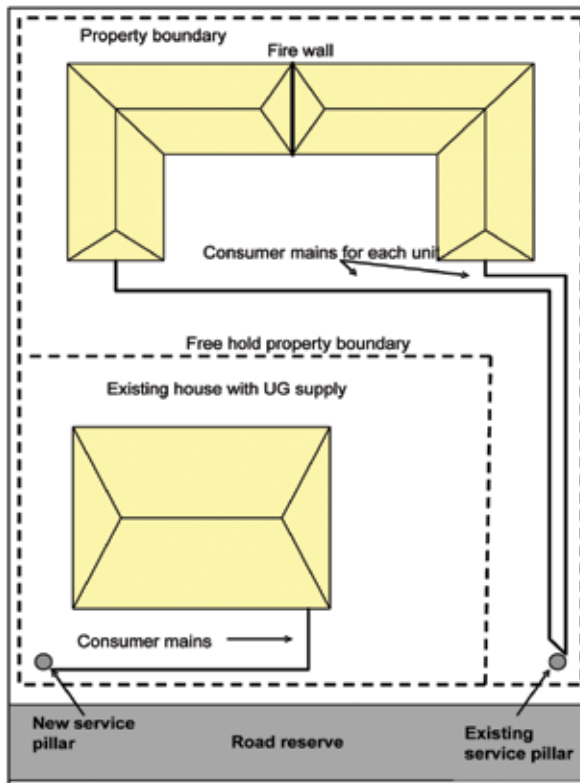

Figure 3.6(g)

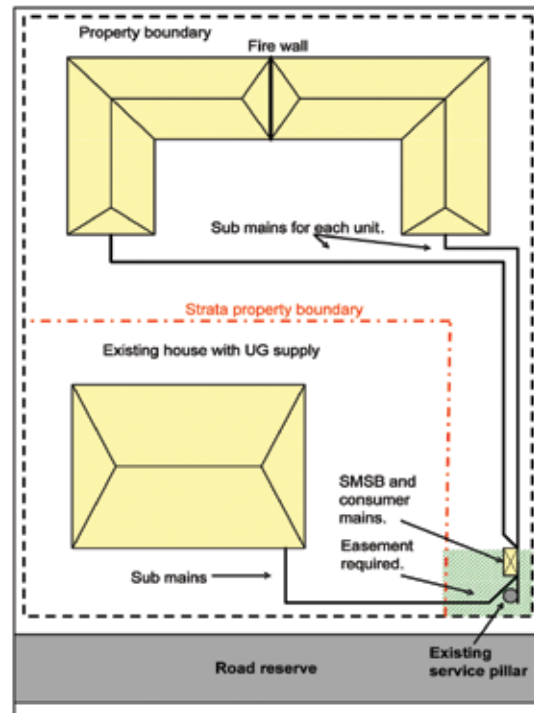

Figure 3.6(h)



3 General Requirements (continued)

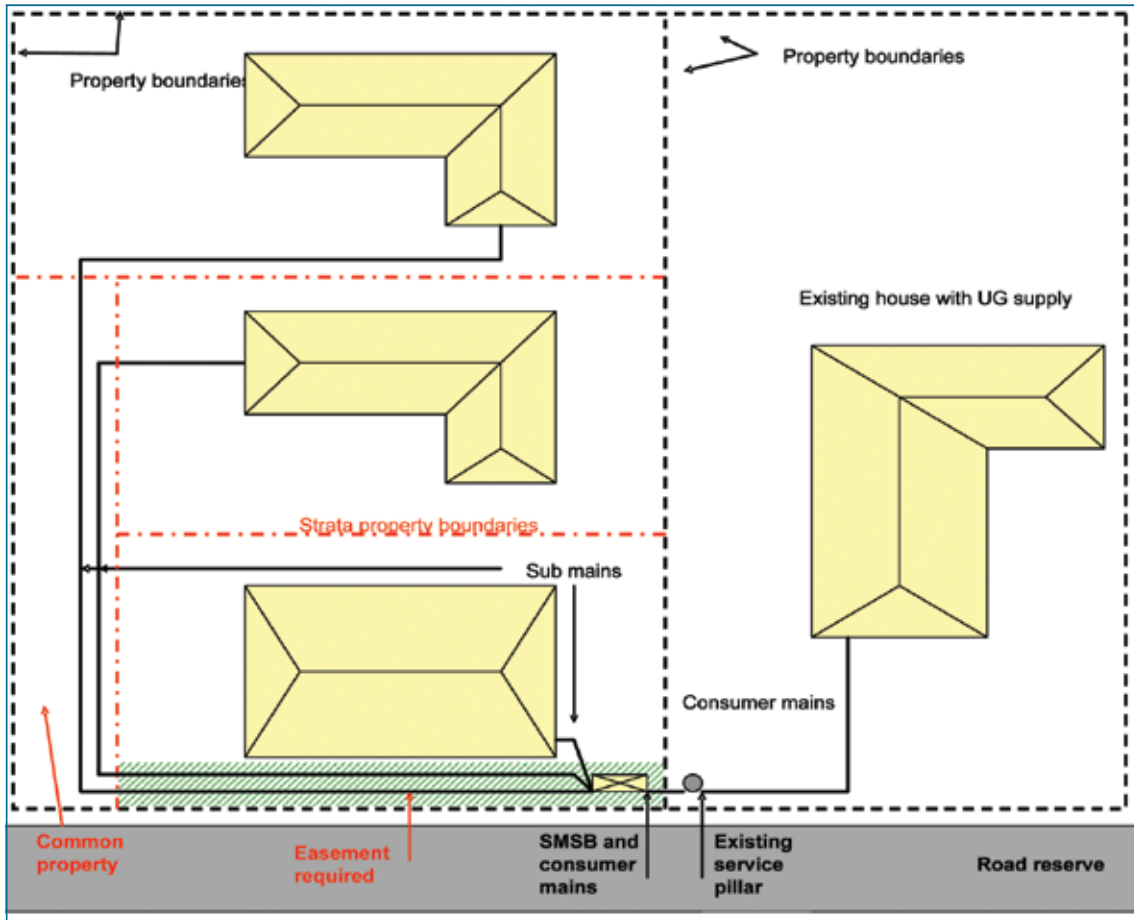

Figure 3.6(i)

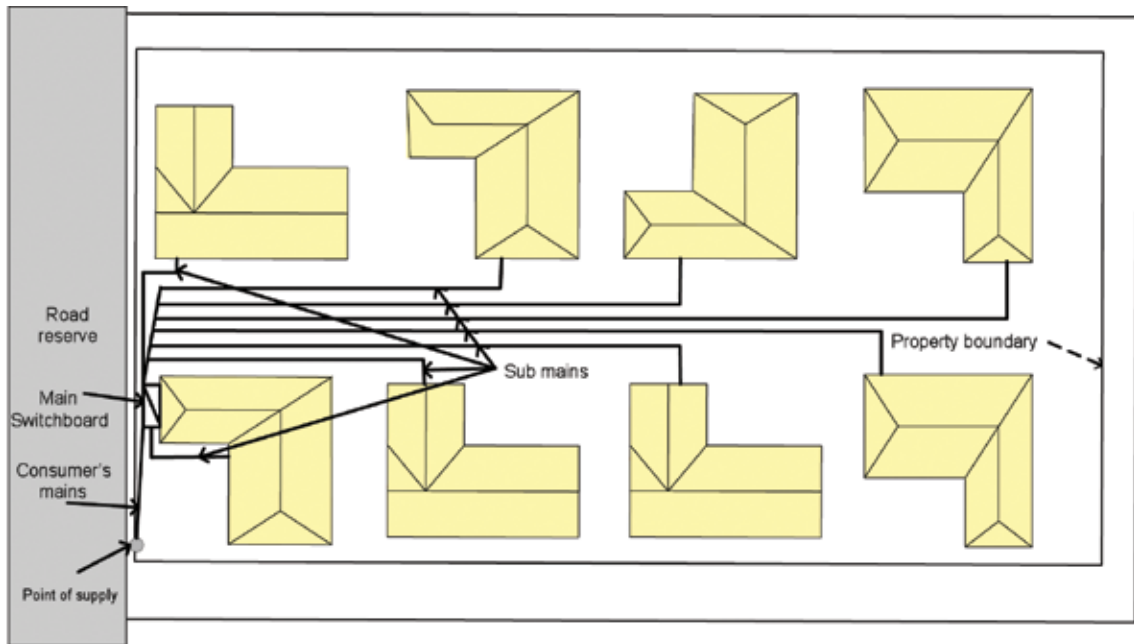

Figure 3.6(j)

### 3 General Requirements (continued)

#### 3.6.1 Standard Domestic Connection

If there is no service pillar provided or to be provided on the lot of a standard domestic connection then the consumer mains of the domestic connection can be connected to a pillar on an adjacent lot provided that the pillar:

- is correctly positioned as per Clause 5.3; and
- has designated available terminals for that connection.

#### 3.6.2 Non-Standard Domestic Connection.

The network operator will determine whether the connection is to be to a pillar, transformer or LV kiosk.

#### 3.6.3 Commercial Connection

Each commercial lot shall have its own point of supply. This shall be a pillar, transformer or LV kiosk located on the lot, or a transformer or LV kiosk located in the immediately adjacent road reserve or public open space.

### 3.7 Removal of Existing Overhead Service

As a part of subdivision, any existing overhead services shall be removed or converted to underground.

### 3.8 Labelling

#### 3.8.1 General

Labels shall be made of non-conducting material, able to withstand ultra violet radiation, extreme weather, and vandalism. They shall be indelible, durable, legible and suitably secured.

Labelling of cables and equipment does not negate the need to carry out appropriate testing, isolation and tagging procedures for both connection and disconnection tasks.

#### 3.8.2 Consumers mains

The installer shall label all underground consumers mains at the point of supply device. This shall be in addition to any Wiring Rules requirement for marking and recording of underground cable locations. Labels shall be fixed to the outer sheath of the cable in a position that is visible without undue manipulation of the termination.

The minimum information on labels shall be:

- Lot or street number (e.g. lot 70); and
- Street name

Where a network operator is connecting consumer mains to its point of supply equipment, they shall ensure the labelling has been fitted as described.

#### 3.8.3 Switchboards

Electrical contractors, before requesting or carrying out energisation of an installation, shall ensure that all switchboards are appropriately and uniquely labelled to identify clearly the board's specific point of supply. If the SPD is located on that board the SPD label shall be sufficient for this purpose.

### 3 General Requirements (continued)

#### 3.8.4 Transformers and LV Kiosk

The network operator normally will include a notice inside the transformer enclosure that a lot has another point of supply where:

- A network operator's transformer or LV Kiosk is situated on a lot or immediately adjacent in the road reserve;
- It is the network operator's normal practice to connect a consumer directly to its transformer or distribution frame; and
- The lot is supplied by other means.

#### 3.8.5 External equipment

Any permanently installed external free standing electrical equipment that does not form part of a single domestic installation shall be fitted with a label(s) identifying the switchboard from which it receives supply using the unique identifier of that switchboard.

**Example:** Supply Origin DB1  
Circuit R3

#### 3.8.6 Notification

Where an electrical contractor or their authorised representative completes the termination of consumers mains, the contractor shall provide the network operator with details of the point of supply as described in clause 3.8.2, and the location of the pillar /consumers pole, linkage to site meters, meter numbers and installation address.

### 3.9 Multiple Points of Supply

A network operator will provide only one point of supply to an individual freehold lot, Crown land title or survey strata plan lot unless unusual circumstances justify more than one and safety concerns are satisfied.

Refer to Figure 3.6(g) & (h) for installations partitioned by fire-rated barriers.

Where a gazetted road reserve traverses a single lot, the network operator may provide a separate supply point to each portion of the lot. Consumer's installation cabling must not cross gazetted road reserves.

#### 3.9.1 General

For existing single lot installations with more than one point of supply, there is no obligation to comply with the requirements of clause 3.9 unless the consumer requires either modification to or an upgrade to one or more of the points of supply to that lot (in which case the requirements of 3.9.1.10 apply).

The following sub-clauses deal with situations where practical and cost considerations mean that more than one point of supply may be requested.

### 3 General Requirements (continued)

#### 3.9.1.1 Zone Diagrams

A consumer may identify zones on a lot to which they require separate supplies of electricity. In such cases the network operator may provide a supply to each such zone if, in addition to any specific conditions, the installation complies with the following:

- No low or high voltage wiring crosses zone boundaries (ELV wiring may cross zone boundaries provided its supply source is identified);
- Zone boundaries, wherever possible follow recognisable site structures or features and do not unnecessarily deviate from direct definitive points;
- The zones do not intermingle or crossover;
- An up-to-date diagram clearly identifying, both electrically and geographically, the extent of every zone and every zone main switchboard location, has been placed in every zone main switchboard, main distribution board in separate buildings and distribution boards supplying external equipment not part of a building;
- Every zone main switchboard has a unique identifier;
- The location of the network operator's service pillars or supply connection panels supplying the consumers main from each zone have been clearly identified on the diagram;
- Current copies of all zone diagrams have been provided to the network operator in an acceptable format ;
- The requirements of clause 3.8 have been complied with, in addition to any Wiring Rules identification requirements;
- In addition to the requirements of clause 3.8, all items within 100m of the dividing zone boundaries not part of a building (for example free standing lighting, pumps or boom gates) have been clearly labelled with the unique identifier of the zone main switchboard supplying them;
- There is a suitable location for the network operator's service pillar(s)/equipment;
- A Notification under Section 70A of the *Western Australian Transfer of Land Act 1893* has been placed on the property title of every and each:
  - i. freehold lot
  - ii. survey strata lot
  - iii. strata plan
  - iv. Certificate of Crown land titles

warning that the property has more than one point of electrical supply. In addition a copy of the zone diagram and all revisions has been lodged with each Notice.

The requirement to supply zone diagrams does not reduce or remove any other requirement to supply specified diagrams.

### 3 General Requirements (continued)

#### 3.9.1.2 Commercial, Institutional and Industrial Premises

A network operator may provide more than one supply point if the requirements listed in Clause 3.9.1.1 and the following, whichever is the more stringent, are met:

- Each zone has a building with a minimum 4 metre-wide ground level street frontage;
- A current copy of all zone diagrams has been provided to FESA and the relevant local government authority in a format acceptable to them;
- Buildings adjacent to each other but located in separate zones have sufficient separation to be deemed as such under the Building Code of Australia (BCA). Notwithstanding the BCA requirements, the minimum separation required between such separate buildings shall be 3 metres to assist emergency and maintenance personnel to identify zones delineation.

A separate zone may be provided for a pump installation provided:

- Pump zone boundaries shall be a minimum of 10 metres from all associated electrical pump equipment and the point of supply;
- Pump and associated switchboard, are 50 metres from any building in an adjacent zone;
- No other non related equipment is connected to the pump supply, (eg. oval lights, boom gates, etc.);
- ELV control cables associated with the pump installation may cross zone boundaries as long as their supply origin(s) are identified.

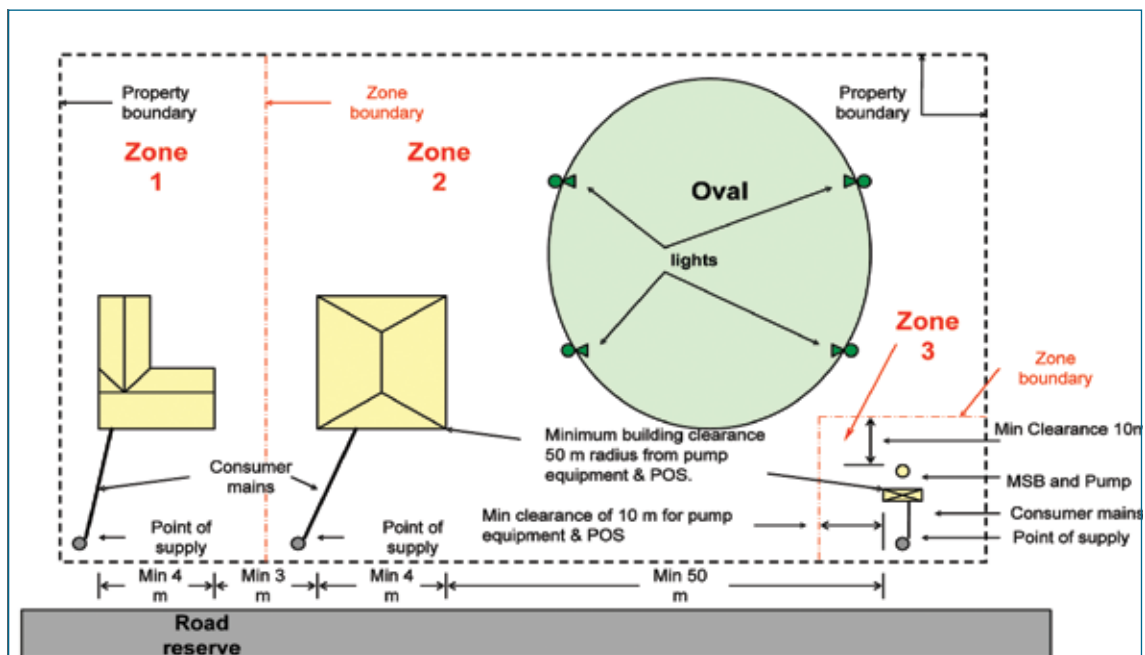

Figure 3.9.1.2 Commercial, Institutional and Industrial Premises – example of zone diagram

#### 3.9.1.3 Strata Plan Lots – Domestic

A network operator may provide more than one supply point to a group of strata lots if the requirements listed in Clause 3.9.1.1 and the following, are observed:

- The zones shall align with the land allocation;
- Each zone has a minimum 3 metre ground-level street frontage and contains a building with a main switchboard;

### 3 General Requirements (continued)

#### 3.9.1.4 Survey Strata – Domestic

For a survey strata plan zoned domestic and comprising two survey strata lots, a network operator may provide a separate supply point for each survey strata lot provided:

- The labelling requirements specified in clause 3.8 have been complied with;
- There is a suitable location for the pillars;
- If the existing dwelling has an overhead supply it is converted to an underground supply (refer clause 3.7).

#### 3.9.1.5 Schools and Reserves

A network operator may provide more than one supply point for school properties and reserves if the requirements listed in Clause 3.9.1.1 and the following requirements are observed. Where a reserve/oval is part of the site and may be used for any sporting event, fete, fair or similar gathering, requiring a temporary electricity supply, the following additional requirements must be observed:

- A permanently installed weatherproof switchboard, must be established on or immediately adjacent to the multiple-use reserve/oval for the supply of temporary power to the aforementioned events;
- The switchboard is to be fitted with an external sign(s) stating that the switchboard is for “supplies to the reserve/oval”, whichever is appropriate, and that supplies from other switchboards are not permitted;
- The sign(s) shall be designed, constructed and placed as set out in Clause 3.8;
- All external permanent electrical equipment in the “reserve/oval” zone shall be suitably labelled to identify its source of supply;
- The switchboard is to be fitted with an additional internal label(s) identifying the main switchboard from which it receives supply using the unique identifier of that main switchboard;
- A current copy of all zone diagrams must be provided to FESA and the relevant local government authority in a format acceptable to them;
- The administrative body for the site must establish and observe a management procedure to ensure all relevant personnel are made aware of the requirements applicable to the use of the “reserve/oval” switchboard;
- The zone diagram(s) installed at all main switchboards must clearly identify the main switchboard supplying the “reserve/oval” switchboard.

The network operator may provide a separate supply for reserve/oval lighting provided:

- Zone boundaries are a minimum of 10 metres from the point of supply;
- Lighting and associated switchboards, are 25 metres minimum from any building in an adjacent zone;
- The switchboard installed for the temporary reserve/oval supplies is located and supplied from within the same zone as the lighting.

### 3 General Requirements (continued)

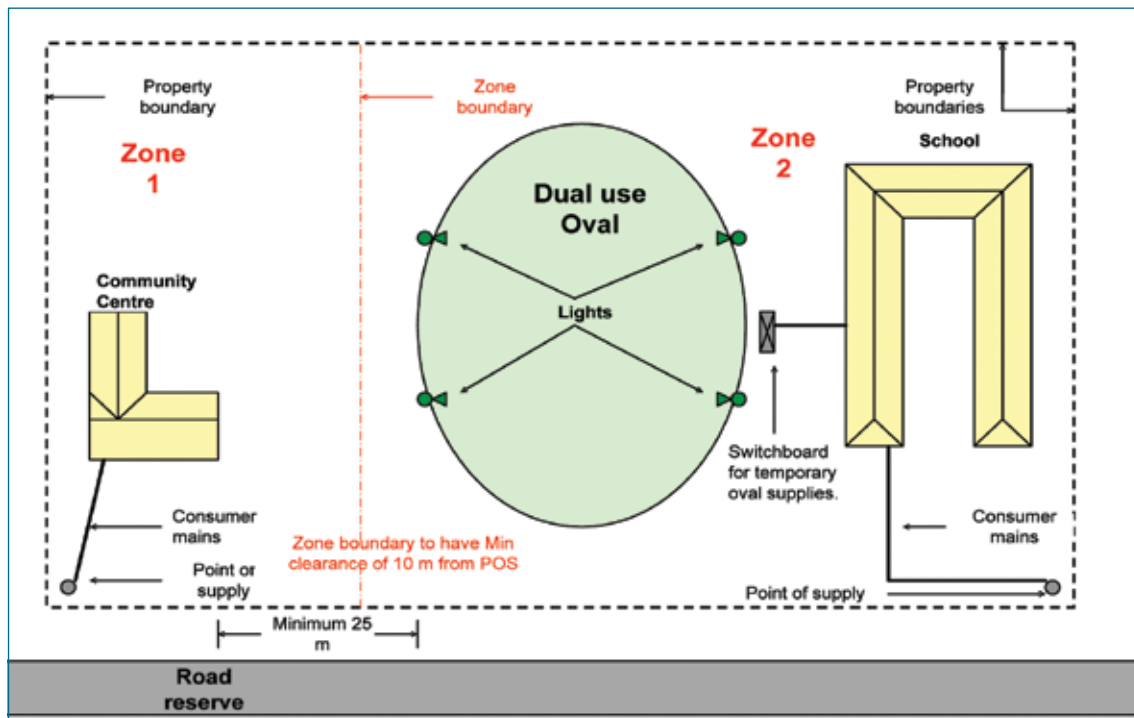

Figure 3.9.1.5 Schools and Reserves

#### 3.9.1.6 Rural and Semi-rural Lots

A network operator may provide more than one point of supply if each is more than 200m from an adjacent point of supply and the electrical services of each installation maintains 50m separation at all times. Where these separation requirements cannot be achieved, the minimum requirements are as set out in Clauses 3.9.1.1 and 3.9.1.2 whichever is the more applicable.

#### 3.9.1.7 Rural Subdivisions Comprising Multiple Survey Strata Lots and Common Property

For large, enclosed, rural subdivisions involving multiple survey strata lots and common property, a network operator may provide more than one point of supply if:

- All equipment downstream from the network operator's transformer or service pillar is owned by the strata company;
- A minimum separation of 200m is maintained for all installation wiring outside of the survey strata lots;
- Main switchboards are established immediately adjacent to the network operator transformer from which they receive supply;
- Easements of adequate dimension are provided by the site owner for the network operator's equipment;
- Service pillars owned and installed by the consumer are readily identifiable as not being the property of the network operator; and
- The network operator's access requirements are met.

### 3 General Requirements (continued)

#### 3.9.1.8 Temporary Builder's Supplies

The following are the minimum requirements for provision of a temporary builder's supply to a lot with an existing point of supply:

- The requirements of Section 10 shall apply.
- The builder shall be responsible for both the permanent and the temporary supplies while the building site is under the builder's care.
- The temporary builder's supply shall service only the building project site within the builder's fenced area.
- No wires or cables energised from the temporary builder's supply shall cross the builder's fence into adjacent land. Where building work takes place on adjacent blocks, both may be given temporary builder's supplies from a service pillar with the network operator's approval.

#### 3.9.1.9 Temporary Supplies for Short Term Events

The following are the minimum requirements for provision of a temporary supply to a lot with an existing point of supply:

- The requirements of Section 8.4 shall apply.
- The event organiser or their representative shall be responsible for both the temporary and permanent supplies during all phases of the short-term event but in so doing the organiser shall not adversely interfere with or interrupt the permanent supply to the site.
- The temporary supply shall service only the event and shall be entirely within the event's operational area, fenced or not.
- No wires or cables energised from the temporary event supply shall cross into adjacent land or beyond the confines of the event concerned.

On completion of the event the temporary supply shall be entirely removed and the site made electrically safe.

#### 3.9.1.10 Existing Multiple Supply Points

Some developed properties already have multiple points of supply. Such situations were sometimes tolerated in the past before the WA Electrical Requirements were made legally binding. Some older or heritage buildings or groups of such buildings may have such supplies and may not comply with modern planning criteria.

When new developments or renovations are proposed for such properties, network operators shall require the supply arrangements to be modified so that they comply with Section 3.9.1.

If a new development or renovations involve only a discrete part of such properties, so that clear separation from the remaining undisturbed portion may be achieved, its modified or upgraded supply shall comply with the relevant part of this Section 3.9.



### 3 General Requirements (continued)

The existing point or points of supply to the undisturbed section may continue in service provided that:

- The undisturbed electrical installation is safe;
- No electrical work is proposed in the undisturbed section, apart from minor work such as installation of an additional light or LV socket outlet;
- The service protection devices are rated to cope with fault levels applicable for each point of supply;
- Up-to-date zone diagrams are prepared showing clearly how every part of the undisturbed section receives supply and placed in every main switchboard in service at the property;
- Copies of the zone diagrams are provided to FESA and the relevant local authority;
- Each point of supply bears sufficient indelible labelling to identify clearly the consumers mains supplying the whole or part of the undisturbed section to enable rapid and precise disconnection of supply in the event of fire.

#### 3.9.2 Management Plans

##### 3.9.2.1 Electrical Safety Management Plan

Where a variation to this document's requirements is implemented, supply arrangements are complex or a requirement of the Occupational Safety and Health Regulations 1996 must be addressed, the consumer may be required to prepare and observe a site-specific Occupational Safety and Health Management Plan. It is the responsibility of the consumer or his representative to ensure that all electrical work performed at the site complies with the Plan, which must meet Occupational Safety and Health Regulation requirements in addition to those set out herein.

These requirements may affect consumers, staff, electrical and other contractors and FESA, and which may stipulate notifications and procedures required by other local, state or federal regulatory bodies. A copy of the Plan shall be made available on request to an authorised representative of the Department of Consumer and Employment Protection or the network operator.

##### 3.9.3 Energisation of Multiple Points of Supply

Prior to requesting energisation or permanently energising the installation for a particular zone, the electrical contractor must satisfy the network operator that they have complied with all stated requirements herein and that they have supplied the applicable information to the relevant entities.

## 4 LV Overhead Network

### 4.1 Connection

The preferred method for all low voltage connections to the distribution system is by service cable installed underground, including those connections that are to be made to an existing overhead distribution line. The network operator will determine if an installation will be supplied by an overhead service.

### 4.2 Route & Point of Attachment

The following factors should be taken into consideration:

- The location of the network operator's poles in the street supplying adjacent properties;
- The position, including its height above ground, of the point of attachment;
- The existence of trees and large shrubs;
- Required clearances;
- The location of any additional consumer's pole/s;
- The selection of the point of attachment to ensure that the route of the service cable is clear of swimming pools, vegetation and building features such as doors, windows, balconies and entrances;
- The location of other utility services; and
- The requirements for service protection, especially for rural supplies.

### 4.3 Crossing an Adjoining Property

A service cable route crossing an adjoining property is acceptable provided a suitable easement is obtained by the consumer over such property. In determining cable routes also refer to Clauses 5.2 and 12.6.

### 4.4 Aerial Consumers Mains

Aerial consumers mains are not permitted.

### 4.5 Spans and Clearances

The network operator shall determine the maximum span for an overhead service line.

The height of supports required to ensure that service lines are installed and maintained at the correct height in non-cyclonic areas shall be determined by the minimum clearances as defined by C(b)1 and AS/NZS 3000, whichever is the more stringent. In cyclonic areas, clearance heights must be approved by the network operator.

Overhead service lines shall not cross over or enter the zones of a pool or water feature as defined by the Wiring Rules.

#### 4 LV Overhead Network (continued)

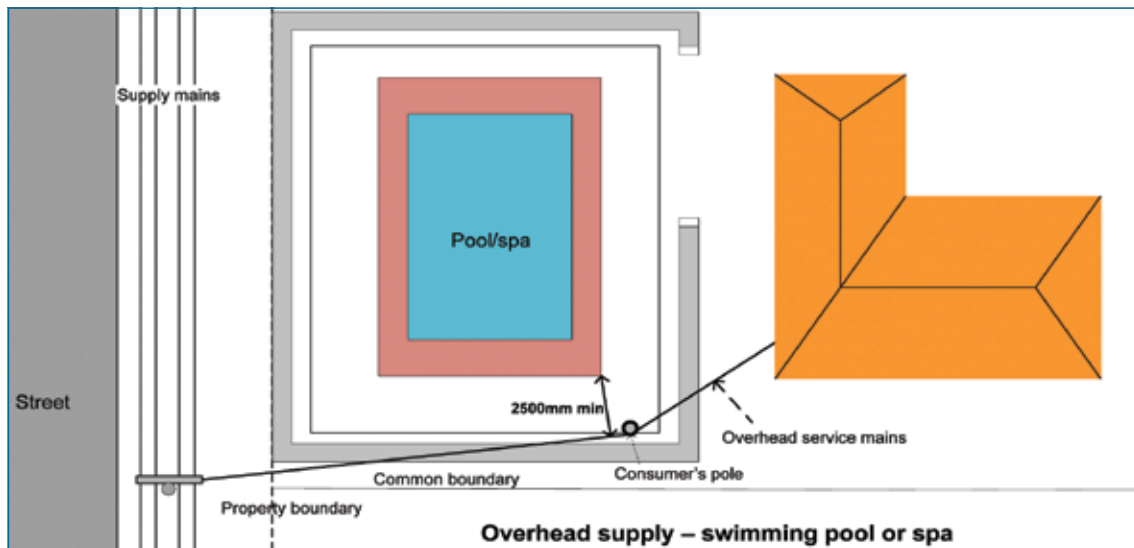

Figure 4.5 Overhead service – pools or spas

Where compliance with this requirement cannot be achieved, the consumer shall either:

- Replace the overhead service line with underground consumers mains connected to a network operator's service pillar; or
- Install an intermediate consumer's pole (Clause 4.7) on the property located to divert the service line away from the pool or water feature zones.

#### 4.6 Point of Attachment

The overhead service cable point of attachment must be located on the aspect of the building facing the supply mains, or on a pole or other structure accessible from the supply system.

The point of attachment shall only be accessible by means of a ladder or an elevating work platform. The area directly below the point of attachment shall be kept clear of obstructions. Access to the point of attachment shall not require a person to walk across any roof or structure.

A minimum clearance of 2.5 metres must be maintained between the finished ground or floor level and the mains connection box or the service leads. The maximum height permitted for a point of attachment is 7 metres from the finished ground level. Where a point of attachment is on a pole, a minimum clearance of 3 metres above ground shall apply.

### 4.7 Consumer and Point of Attachment Poles

Consumer and Point of Attachment poles in non-cyclonic areas shall comply with the Wiring Rules and be capable of withstanding a horizontal force of 2250N applied 5.2 metres above ground without the deflection at the point of application exceeding 230 mm. There shall be no permanent deformation.

A galvanized steel pipe of 114 mm OD with a minimum wall thickness of 4.5 mm is deemed to meet the strength requirement. Any hole provided in the pole for the entry or exit of cables shall be constructed to prevent moisture ingress into the pole. The entire assembly shall be hot-dip galvanized.

The pole shall be capped at the top to prevent moisture ingress and be securely embedded in a concrete base. Point of Attachment poles must be placed in a concrete foundation designed to prevent deflection from the vertical caused by the unbalanced force exerted by the overhead service cable. The overhead service support structure must be capable of withstanding the load imposed by the service cables.

The design and specification for all Consumer and Point of Attachment Poles used in areas subject to cyclonic winds shall be approved by the network operator before installation.

Consumers may be required to install a pole to ensure that:

- Aerial ground clearances above both trafficable areas and property comply with the Wiring Rules;
- Loads on poles and fittings do not exceed equipment specifications and capabilities;
- Aerial spans do not exceed acceptable limits;
- Aerial spans do not pass too close to pools, spas and other buildings.

A network operator may elect to install the consumer and/or point of attachment poles in certain cases, but the consumer remains responsible for the continuing maintenance of such poles after installation.

## 5 LV Underground Network

### 5.1 Connection

The preferred method for all low voltage connections to the distribution system is by underground service cable, including connections made to an existing overhead distribution line in the street verge.

The network operator will determine the method of connection to be used including:

- Location and point of supply;
- Type of pillar, pit, panel or frame to be used;
- Service cable route.

Special arrangements may apply to consumer's installations supplied at high voltage or from multiple transformers. Where relevant, the details will be included in the network operator's connection agreement.

### 5.2 Cables and Enclosures

For multiple installations, common property or easements shall be created to allow consumer mains to be connected to the pillar and or sub-mains to be connected to the site main switchboard. Cables shall run parallel to or perpendicular to the property boundary and shall be within 1.0m of those boundaries.

At the network operator's discretion, a service easement may be substituted where a survey strata lot is created and common property is required across the front boundary to ensure all lots can access the pillar with their consumer mains (Figures 3.6(e), (h) & (i)). The customer is responsible for all costs associated with the creation of the easement.

Consumers mains cables shall be insulated, sheathed and installed in a heavy-duty non-metallic enclosure. Burial depth shall be a minimum 500 mm below finished ground level.

If a depth of 500 mm cannot be maintained because of rock, the consumers mains may be installed as a Category "C" system, with a concrete cover, in accordance with the Wiring Rules. The concrete cover is to provide mechanical protection over the entire length of the installed cable. The concrete cover shall be in addition to all other coverings such as driveways.

Category "B" systems as defined by the Wiring Rules shall not be used as consumer mains unless approved by the network operator.

Conduits for above ground out-door use shall be of a heavy-duty type and treated to withstand ultra-violet radiation or painted orange with a light-coloured water-based acrylic paint.

Steel wire armoured cable is not permitted for use as consumers mains.

### 5.3 Service Connection Devices

The network operator will provide and install a service connection pillar, pit, panel or frame to facilitate connection of the consumers mains. For pillars, cable entry is from the bottom and no entry holes are to be made in the pillar housing.

The network operator shall determine the service pillar location. Where possible the centre of the pillar should be within an area not more than 500 mm from the front boundary and from the common boundary of the adjacent property.

## 5 LV Underground Network (continued)

A vertical and 600 mm horizontal exclusion zone shall be maintained around service pillars providing sufficient clearance to allow network operator staff, emergency personnel and electrical contractors to remove the pillar cover easily and work safely while completing or removing service connections, operating links or fuses. The zone shall also ensure maintenance of earth stake clearances as prescribed by AS/NZS 3000.

Trees, shrubs, fences and garden features such as fishponds, gazebos and ornamental paths shall not be placed within the exclusion zone of service pillars. The consumer shall ensure that access for authorised persons to the pillar is maintained at all times. Where pillars are located adjacent to trafficable areas they shall be protected by network operator-approved robust bollards or other protection such as a concrete barrier.

While in most cases only two adjacent residential lots will be supplied by one pillar, the network operator may choose to vary this requirement.

Wherever possible, pillars shall be installed at street level and in all cases shall be placed on the low side of boundary retaining walls.

Appropriately-sized heavy-duty PVC conduits shall be provided to facilitate future consumers mains and cable installation.

Where retaining walls are required, they shall incorporate a setback of sufficient dimensions to allow safe work on the pillar. Alternatively, provision must be made for a network operator's surface or recessed wall-mounted connection panel.

If properties are built out to the street boundary, incorporating parapet walls or high frontal retaining walls across the entire front boundary, the network operator may approve the use of service connection panels in lieu of pillars. Such panels shall be recessed into parapet or stone retaining walls. The contractor must install heavy-duty conduits of sufficient diameter, length and number to enable supply connection to the network operator's underground cables and consumers mains to all properties affected.

### 5.4 Building Entry

Provision shall be made during construction of the building for the consumers mains conduit to pass through the building foundations and into either the building or the wall cavity.

If such provision has not been allowed, the portion of this conduit rising up to and around the footing to the point of entry into the wall cavity shall be protected against impact damage, movement and water ingress by robust means such as a galvanised steel pipe or equivalent (refer also to Clause 12.4).

5 LV Underground Network (continued)

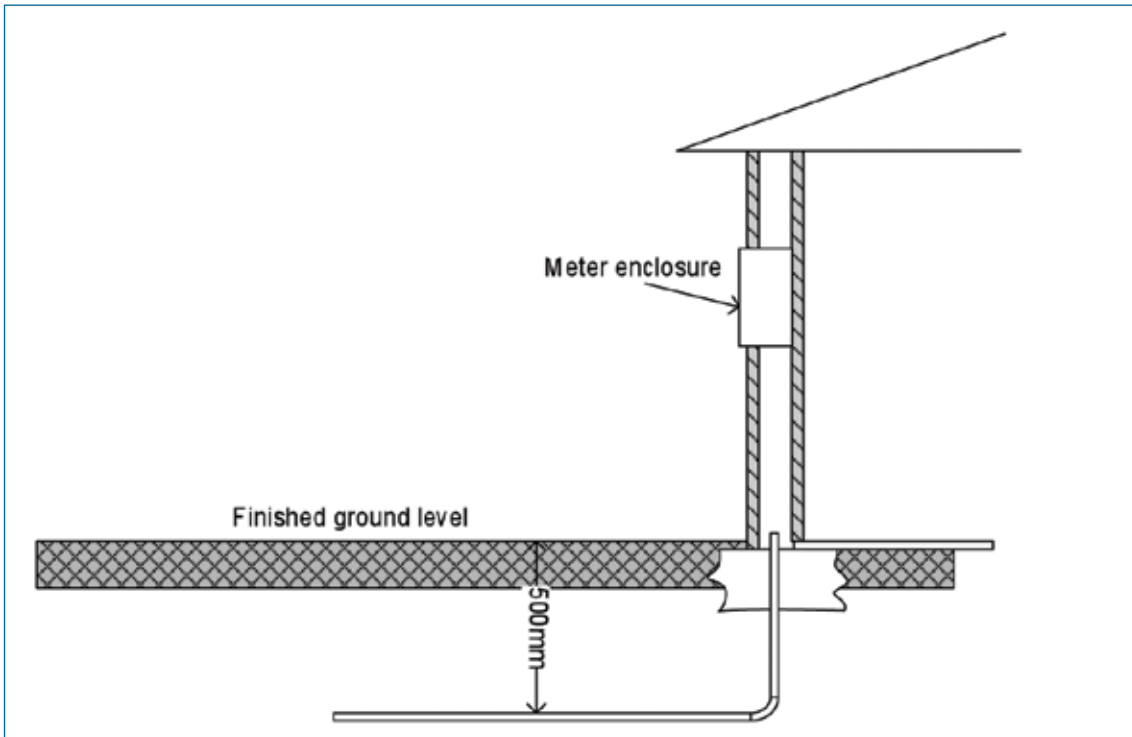

Figure 5.4(a) Conduit entry through slab

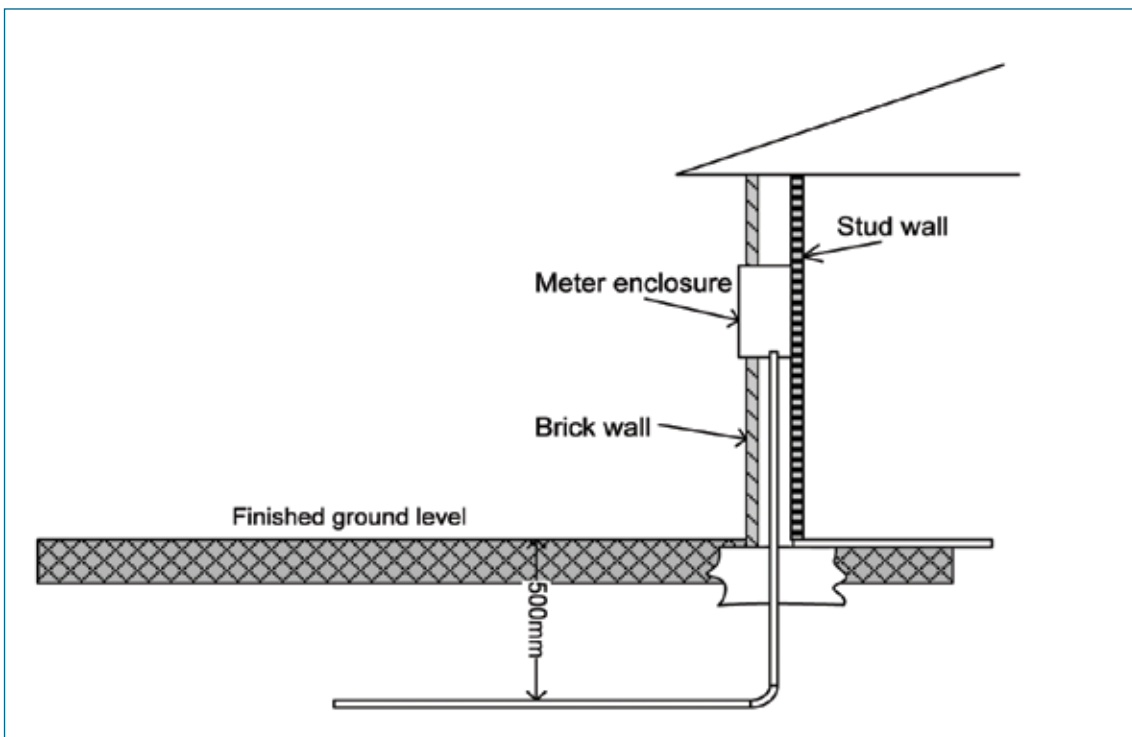

Figure 5.4(b) Conduit entry brick veneer

5 LV Underground Network (continued)

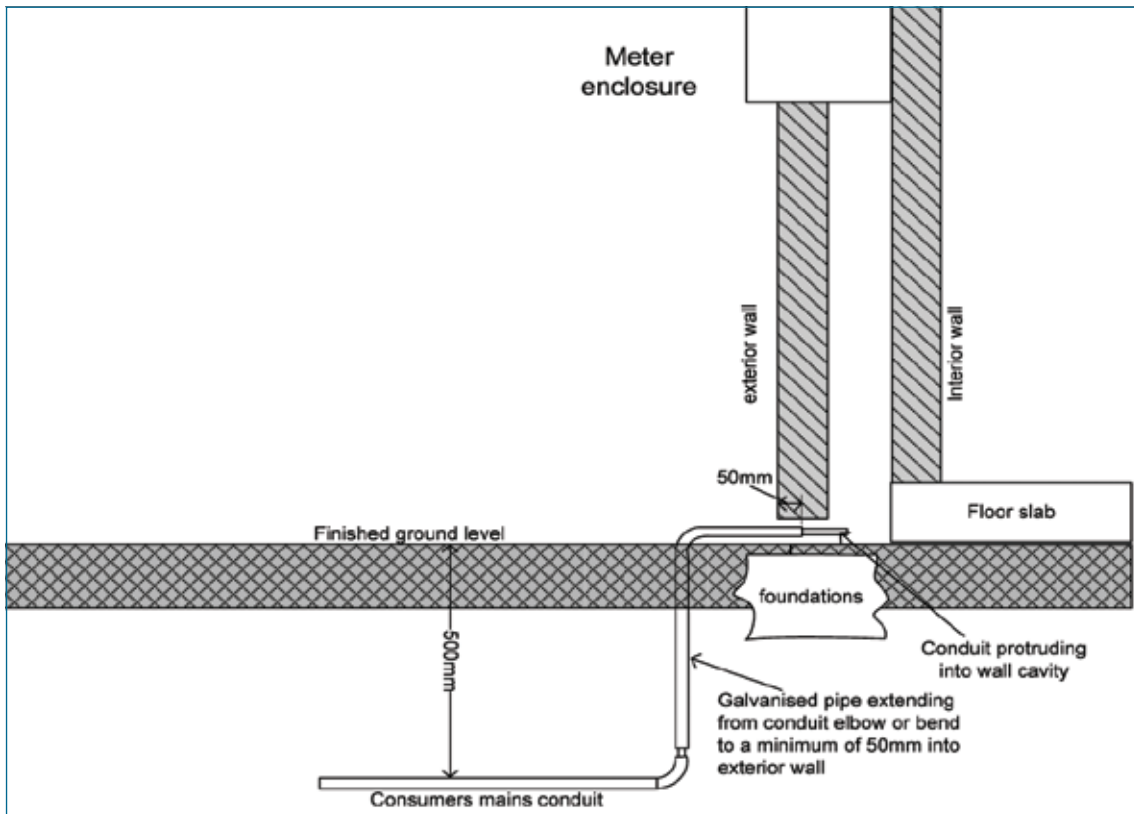

Figure 5.4(c) Conduit entry through wall

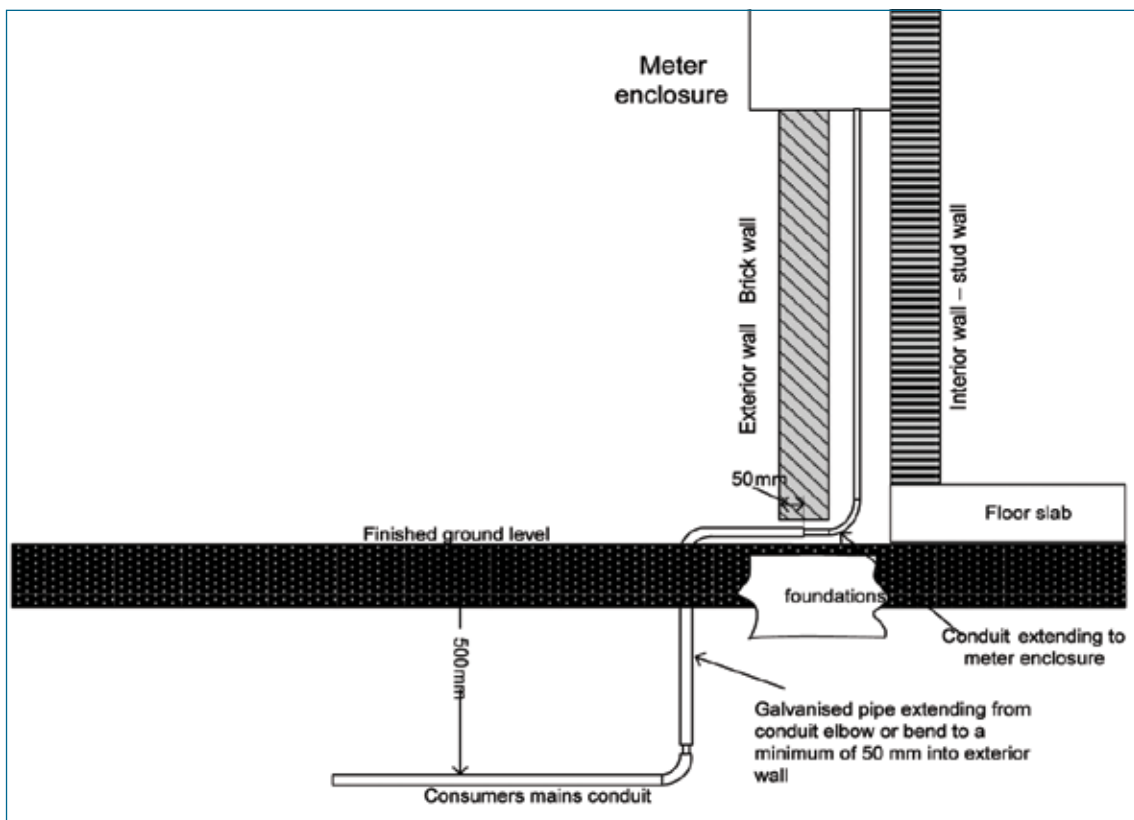

Figure 5.4(d) Conduit entry brick veneer



## 5 LV Underground Network (continued)

### 5.5 Other Services

If the consumers mains are installed near gas, water or telephone services, they shall be installed in accordance with the Wiring Rules and related standards.

### 5.6 Network Operator's On-site Substation

Where a network operator's substation is to be located on a consumer's property, the electrical consultant or contractor shall obtain details of the supply arrangement from the network operator.

#### 5.6.1 District Substations

District substations incorporate a low-voltage interconnection with the supply mains.

Where the installation main switchboard is contiguous with the network operator's substation enclosure, the consumers mains do not require over-current protection. If not contiguous, the consumers mains must have over-current protection in the substation.

#### 5.6.2 Sole-Use Substations

Sole-use substations do not provide a low voltage interconnection with the supply mains. However in special circumstances (e.g. very large sites) a separate LV supply may be provided to an isolated part of the overall site installation, if approved by the network operator.

The main switchboard shall be contiguous with the substation enclosure and provide visible means of isolation.

### 5.7 Contractor Termination of Consumers Mains

A network operator may authorise an electrical contractor to terminate the consumers mains at the supply pillar or connection panel, and at the connection point. Where a multi-point terminal block is provided in network equipment, only one wire of a consumers mains cable shall be terminated in each tunnel of the terminal block. The network operator is to be contacted if there are insufficient vacant tunnels to complete the termination, which must not proceed until a suitable arrangement has been decided by the network operator.

Doubling of active conductors in one tunnel is permissible for street light circuits.

## 6 Metering and Service Equipment

### 6.1 Basic Requirements

Metering shall comply with the requirements of the network operator and the following:

- Meters shall be located so that the network operator's staff or contractors have unimpeded access for reading and maintenance. Meters with a remote reading facility may be located in a secure area with access arrangements agreed with the network operator;
- Enclosures shall prevent the entry of water and minimise spread of fire. They shall be designed to ensure that under normal operation contact cannot be made with live parts. Meters may be installed on hinged panels provided the wiring is appropriately secured and protected;
- The consumer shall provide service protective devices to protect the metering equipment from fault incidents within the installation, to allow the safe replacement of meters and to provide an electrical isolation point. The device will usually be located adjacent to the meter;
- Network operator metering equipment, with all service links, fuses and service protection devices on the supply side of the meter, shall be provided with a robust facility for fitting seals;
- The network operator may specify the fitting of seals to all or specific items of equipment and, where such seals are installed, they shall only be removed by a person authorised by the network operator;
- In multiple-meter installations, it shall be possible to remove any meter without interrupting the continuity of the installation's neutral connection or supply continuity to other consumers.

### 6.2 Responsibilities

#### 6.2.1 The consumer

The consumer shall provide, install and maintain:

- Service protective devices, meter fuses or meter circuit breakers, where required (except fuse cartridges);
- Service neutral/active links;
- The meter enclosure and panel;
- The switchgear enclosure;
- Consumers mains;
- Associated wiring and connections;
- Labels.

#### 6.2.2 The network operator

The network operator shall supply, maintain, and when required, install the revenue meters but not the panels, wiring or enclosures.

#### 6.2.3 The electrical contractor

The electrical contractor shall:

- Assess the maximum demand to determine the correct selection of service apparatus and metering equipment.
- Where accredited, install and connect direct-connected metering for supplies up to 100A; and
- Where the network operator agrees that the maximum demand will exceed 100a per phase for separately metered parts of an installation, arrange for the installation of current transformer (CT) metering to comply with the network operator's requirements.

## 6 Metering and Service Equipment (continued)

### 6.3 Location and Accessibility

Switchboard-mounted service and metering equipment shall be located in accordance with the network operator's requirements so that it is accessible from the street level of the building or one floor above or below street level for multi-storey buildings.

The network operator's point of supply shall have unimpeded access 24-hour/7 days a week.

Metering equipment must be easily accessible to network operator officers during normal network operator working hours.

If the metering equipment is located inside the premises, the consumer shall arrange for the SPD to be accessible for network operator and essential personnel.

The network operator may consider an alternative arrangement for the installation of remote meter-reading facilities.

The metering equipment must be located on common property for multiple-dwelling installations. Labels complying with Clause 3.8.1 must clearly identify the building, service protection device and meter for each dwelling unit.

Access to switchboard-mounted service and metering equipment enclosures must never be restricted or made unsafe. The location must always be kept clear.

Adequate space shall be provided and maintained in front of the enclosure to enable the metering equipment to be operated, maintained or replaced.

The space must:

- Comply with the Wiring Rules;
- Enable the door or panel to be opened or removed;
- Provide a vertical clearance of not less than two metres from the ground, floor or platform;
- Provide a minimum horizontal clearance of not less than 600mm from either the equipment, if mounted on the hinged panel, or the external front edge of the switchboard enclosure, whichever is appropriate;
- When a meter panel is extended on its hinge to the 90° open position, a clearance of 200 mm is to be maintained between the front face of the panel in its open position and any fixed object;
- If the panel is enclosed in other than a standard meter enclosure, a clearance of 175 mm from the front of the panel to the door is to be provided;
- The bottom of panels shall be generally 900 mm from the floor or ground surface but in all case shall not be less than 600 mm.

#### 6.3.1 Single Domestic Premises

Switchboard-mounted service and metering equipment must be located as close as practicable to the road frontage entrance of the premises and must be accessible without entering the dwelling or traversing areas not normally open to the public.

For single lots with a gazetted road frontage and an area of up to 2500m<sup>2</sup>, the meter shall be located in accordance with the network operator's requirements.

## 6 Metering and Service Equipment (continued)

For battle-axe lots with an area up to 2500m<sup>2</sup> with no street frontage, other than the driveway or part thereof, the meter may be located on the individual dwelling as closely as practicable to the entry of the premises.

For domestic lots with an area exceeding 2500m<sup>2</sup>, refer to Sections 3.6 and 6.3.3 for details about meter locations.

### 6.3.2 Multiple Occupancy Domestic/Commercial Premises

Generally metering and the related service protection device(s) must be so arranged to allow the electricity to individual premises and all of them collectively to be switched off at any time.

This requirement may be varied by agreement with the network operator should the freehold title lot have more than one point of supply.

### 6.3.3 Rural and Semi-rural Installations

In addition to Clauses 6.1 and 6.2, the meter shall not be more than 30 metres from the point of supply. The meter must be positioned so that the meter reader does not have to enter an area enclosing animals, open gates or climb stiles to reach the meter.

### 6.3.4 Commercial Installations

In addition to clauses 6.1, 6.2 and 6.3.2, the meter(s) must remain accessible when the building is locked, unless other arrangements are made with the network operator.

### 6.3.5 Remote Metering (extended load tails)

In addition to clauses 6.1 and 6.2, a meter and associated service protective device may be located up to 30 metres from the consumer's main switchboard.

Remote metering is limited to domestic, commercial and industrial installations in self-contained, separate buildings.

Remote metering may not be used for multiple master metering installations.

The remote metering enclosure shall be earthed by soldering to the load neutral a conductor of cross sectional area not less than the consumers mains conductors. If the remote metering enclosure is mounted on a steel-framed building, an earth conductor of the same size as the neutral conductor shall be installed from the switchboard to earth to prevent creation of a parallel path.

## 6 Metering and Service Equipment (continued)

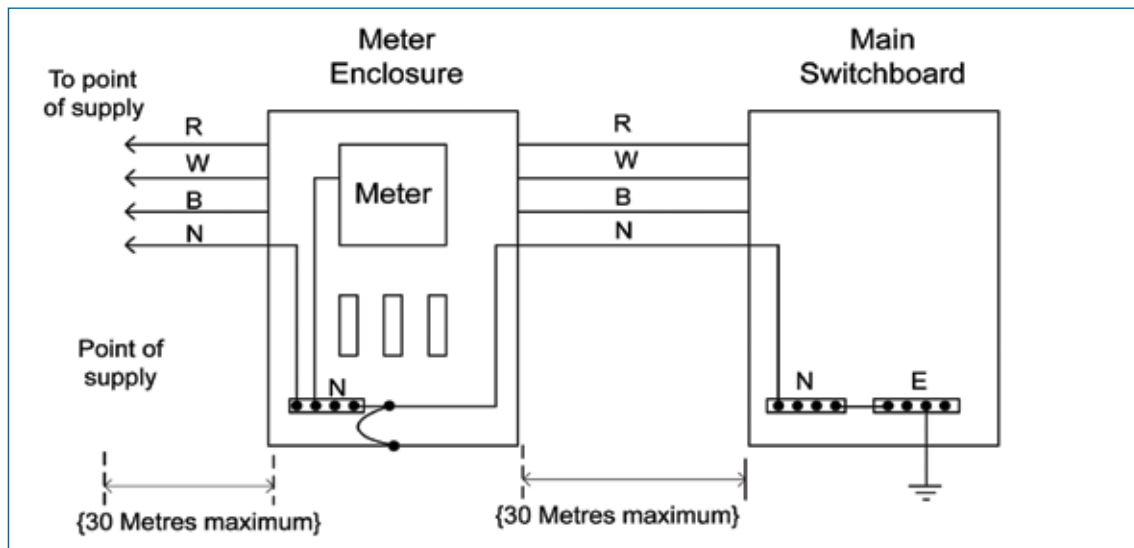

Fig. 6.1 Arrangements for neutral bonding of remote meter enclosure

### 6.4 Unsuitable Locations

Switchboard-mounted service and metering equipment shall not be located:

- Over stairways or ramps, in narrow passageways, or in confined spaces;
- In vehicle docks, driveways, factory passageways where the equipment or a person working on it would not be effectively protected;
- In close proximity to, or over, machinery or open-type switchgear;
- In locations subject to flooding, fumes, vibration, dampness, or dust, which may cause deterioration of equipment or unsatisfactory working conditions;
- In hazardous or prohibited switchboard locations as defined in the wiring rules;
- Where the normal ambient temperature exceeds 50°C;
- Where there is insufficient light;
- Where exposed to direct sunlight;
- Where the use of a ladder would be necessary to access network equipment;
- Where projections are a hazard;
- In pool or spa areas;
- In carports (except for approved AMR systems);
- On enclosed verandahs (except for approved AMR systems);
- In areas enclosing animals;
- In areas to which access is normally restricted – for security, health or other reasons (this would include areas in which animals are kept for security reasons) (except for approved AMR systems);
- Behind a fence, unless with an unlocked, suitably positioned gate (except for approved AMR systems);
- Near gas cylinders (refer to AS/NZ 2430.3.4);
- In fire-isolated stairways, passageways or corridors; and
- Where access is restricted by vegetation.

## 6 Metering and Service Equipment (continued)

### 6.5 Protection

#### 6.5.1 Enclosure

Switchboard-mounted service and metering equipment must be mounted on a panel installed in an enclosure approved by the network operator.

The panel shall be constructed using a rigid, insulating non-hygroscopic material. Panel dimensions must be sufficient to accommodate the service protection device, meter(s) and the consumer's main switch without undue bending or strain on wiring or difficulty during maintenance.

Where the network operator has not specified the dimensions of a panel, sizes should be either:

- 450 mm high x 225 mm wide x minimum of 6 mm thick; or
- 450 mm high x 450 mm wide x minimum of 6 mm thick.

Manufacturers of enclosures shall, prior to manufacture or modification of panels, seek and obtain formal approval of their design(s) from the network operator.

#### 6.5.2 Physical Protection

Switchboard-mounted service and metering equipment must be protected from:

- The weather, including direct sunlight;
- Mechanical damage;
- Salt or dust-laden air or corrosive atmospheres; and
- Vandalism.

Where an enclosure is used to protect the equipment, it must be fitted with a hinged door and catch.

#### 6.5.3 Isolated and Unattended Locations

Where service and metering equipment are installed in an enclosure externally on a building or a pole in an isolated and unattended location, the enclosure must be constructed of material of sufficient strength to achieve protection against vandalism, weather or other external factors and be fitted with a lock using the network operator's standard locking system.

### 6.6 Metering Configurations

The consumer is responsible for supplying and installing all switchboard-mounted service equipment. The revenue meter will be supplied by, and remain the property of, the network operator.

Each direct connected meter shall have individual meter protection, which can be, in the case of a single meter installation, the SPD. Where there are multiple meters downstream of the SPD, individual meter protection via a specific meter fuse or meter circuit breaker shall be provided.

For direct connected metering, the consumer shall arrange for the installation and termination of the revenue meter.

For Current Transformer (CT) connected meters, the network operator will install and terminate the meter. Where High Voltage (HV) metering is required, the supply and installation of the metering equipment will be as specified in the connection agreement.

## 6 Metering and Service Equipment (continued)

### 6.6.1 Direct Metering 240/415V up to 100A

For all applicable loads up to and including 100A per phase, direct connected meters shall be used. This limit may vary subject to meter configuration and/or network operator specification.

### 6.6.2 Current Transformer Metering

#### 6.6.2.1 Introduction

Where the network operator agrees that an installation's assessed load, or a portion of it, exceeds the limits specified in clause 6.6.1, current transformer (CT) metering is required. The consumer is required to provide and install the CTs, the voltage circuit to the meters (including protection for this circuit) and facilities for mounting the meters.

#### 6.6.2.2 Voltage Circuit Protection

Two protection measures shall be provided. The first shall comprise a set of fault current limiters mounted on the 415-volt busbars on the supply side of the current transformers. A 32A HRC fuse link shall be installed in each limiter by the switchboard manufacturer.

The second shall comprise a set of potential fuses mounted on a suitable bracket in an accessible and safe position. A 6A HRC fuse link shall be installed in each potential fuse by the switchboard manufacturer.

The consumer shall provide and install the potential fuses and fault limiters, which shall be either:

- a current limiting (HRC) type NS to AS 60269.1 2005 'Low voltage fuses – uses with enclosed fuse-links' Parts 1 and 30, in an enclosure with class IP2X to AS 1939 'Degrees of protection provided by enclosures for electrical equipment (IP Code)', or
- Class G current limiting (HRC) fuse links in a modular fuse holder complying with IEC 60269 – Part 2.

The fuses must be installed so that they are extracted away from the face of the panel and towards the operator.

A clearance of between 100 mm (minimum) to 300 mm (maximum) between the panel and the enclosure door shall be provided.

Alternative forms of potential fuse mounting include:

- DIN rail;
- securely fixed on a steel bracket, provided the mounting screw hole is covered with a suitable insulating material.

#### 6.6.2.3 Current Transformers

The consumer shall provide and install the CTs. They must comply with the network operator's requirements. The secondary terminals of the CTs are to be short-circuited to prevent inadvertent damage and electric shock. The network operator's personnel, when commissioning the metering installation, will remove the short circuit bridges.

The CTs shall be mounted with the polarity marks P1, L or a distinctively coloured dot adjacent to the terminals facing the incoming supply.

Meters may be installed in an enclosure separate from the switchboard containing the current transformers provided the secondary wiring does not exceed 10 metres from the CT terminals to the meter terminals.

## 6 Metering and Service Equipment (continued)

### 6.6.3 HV Metering

Refer to Section 7 and the relevant network operator for specific details.

### 6.6.4 Alternative Metering Options

Alternative metering arrangements can be applied to specific installation types. Examples of such arrangements include:

- Multiple master metering
- Distributed master metering
- Smart power metering
- Automated meter reading

Reference should be made to the relevant network operator for specific details pertaining to any of these metering arrangements, as variances may exist on their requirement for installation and connection.

## 6.7 Neutral Link

Neutral links must:

- Be insulated from earth;
- Be fitted with a cover suitable for sealing where direct contact is possible;
- Have a separate terminal for each conductor;
- Have a current rating not less than the current carrying capacity of the incoming conductor;
- Be located so that they are easily accessible and safe to work on;
- Be labelled.

If a link is mounted on the rear of the panel, the panel shall be hinged.

## 6.8 Service Protection Devices

### 6.8.1 Introduction

A Service Protection Device (SPD) is required in all customer installations supplied at low voltage. The SPD shall be connected to the consumers mains from the network operator's point of supply. An SPD and a main switch must always be provided on whole current metering. The SPD does not replace the main switch, except for sole-use substations, where the transformer circuit breaker need not be duplicated. The SPD shall be installed on the line side of meters or metering CTs.

For supplies taken from district substations, the SPD for the consumer's installation shall be a circuit breaker, fitted with over-current protection.

All circuit breakers used as an SPD and main switch(s) shall have the facility to be locked and tagged in the "off" position. Where a fuse is used as an SPD, or as a meter fuse, it shall be capable of being sealed and tagged in a de-energised configuration.

All switchboards, both main and downstream distribution boards, shall be fitted with main switches in accordance with the Wiring Rules and shall have sub-main circuit protection in addition to the SPD.

A switch or circuit breaker shall be installed downstream of each CT master meter. It shall have provision for being locked and tagged in the "off" position.



## 6 Metering and Service Equipment (continued)

The consumers mains, SPD and main switch(s) and customer's equipment shall be coordinated so that the fault ratings of the SPD and the main switch(s) are adequate, based on the network operator's nominated prospective fault current at the point of supply and as required by the Wiring Rules. This can be less than the maximum prescribed fault level but must be upgraded if the fault level subsequently rises.

The protection operating curves of the SPD must grade with the network operators upstream protection.

Where wiring systems and equipment for safety/emergency systems have been installed downstream of the SPD, the SPD shall be labelled:

### **Safety (Emergency) Systems on Site SPD To Be Operated Only by an Authorised Person**

#### 6.8.2 Location

An approved service protective device, appropriately labelled, shall be provided by the consumer and shall be located:

- Generally on the main switchboard;
- In an accessible location for installations with a remote reading facility;
- No more than 2.0m to the top of the device above the ground, floor or platform.

#### 6.8.3 SPD for Direct Metering

The service protection device shall limit let-through fault currents to 6kA. If the chosen SPD is a HRC fuse or fuses, they shall:

- Have a continuous rating of 100A (base and holder);
- Be capable of correct grading with the upstream protective devices;
- Be correctly graded with downstream protective devices to suit customer and Wiring Rules requirements;
- Be back wired (not studs);
- Be able to be sealed when the fuse carrier is inserted using facilities cast into the base and carrier;
- Have all live parts shrouded; and
- Be suitable to accept a Type IIb current limiting (HRC) fusible link manufactured to the requirements of AS 60269.32005 (30 mm barrel) or its IEC equivalent Standard.

Consumers wishing to use circuit breakers as an SPD may do so. Such circuit breakers shall be of an approved manufacture and type and shall have:

- A maximum let-through fault current of 6ka;
- A rated short circuit breaking capacity equal to or greater than the prospective short circuit current at their point of installation, and in any case, except as follows, shall not be less than 25ka. A circuit breaker with a rating lower than 25ka may be used if the installation configuration is:
  - Single phase with a minimum of 15 metres of 16 mm<sup>2</sup> (or smaller size) of consumer mains – 6ka;
  - Three phase with a minimum of 20 metres of 10 mm<sup>2</sup> (or smaller size) of consumer mains – 6ka.

## 6 Metering and Service Equipment (continued)

- The capability of ensuring discrimination, with the upstream protective devices;
- The capability of ensuring discrimination, with the downstream protective devices to suit customer and Wiring Rules requirements;
- Additional phase failure protection if the device does not operate all phases simultaneously;
- A continuous current rating not exceeding 100 A;
- Termination compatibility with service conductors; and
- Enclosed live parts.

### 6.8.4 SPD for CT Metering

The service protection device (SPD) shall comprise a circuit breaker(s) of appropriate rating for single or three-phase configurations. The network operator will provide the grading requirements after the supply arrangement has been determined.

Where there are two or more transformers in parallel, the SPD overload protection must be set to prevent damage to the network operator's upstream equipment in the event of one SPD tripping or being switched off in error.

## 6.9 Energisation

The electrical contractor may operate the SPD to check the operation of the meter(s) where direct connected meter(s) are installed.

On completion of this work, either the fusible element(s) shall be removed or the circuit breaker(s) returned to the "off" position and tagged.

The electrical contractor shall inform the network operator of the termination details (Clause 3.8).

A caution tag shall be attached to the SPD(s) to indicate that only the network operator's authorised representative may remove the tag and energise the installation. This will be done after receipt of the Notice of Completion from the electrical contractor.

An electrical contractor, accredited as a part of a network operator-approved scheme, may leave an installation energised on completion of the required commissioning processes. Electrical contractors shall refer to the relevant network operator for details of such schemes.

## 7 High Voltage Installations

### 7.1 Design

Consumer high voltage installations must be carefully designed, constructed, maintained and operated by competent persons to ensure the safety of personnel, equipment and property.

Inquiries about high voltage supply and installations should be directed to the network operator. For supply at 66kV or greater, inquiries should be directed to the transmission system network operator.

Private high voltage generation must comply with this Section and Sections 8 or 9 as appropriate.

### 7.2 Basic Requirements

The fundamental requirements specified in Regulation 49 of the Electricity (Licensing) Regulations 1991, Section 12 and this Section must be observed to ensure that HV installations:

- Are safe to use, maintain and operate, recognizing that higher voltages and related fault levels are more dangerous, demanding additional attention to manage the risks to an acceptable level; and
- Are suitable for connection to an electricity supply network, where this is intended.

The requirements of this section do not apply to:

- Electric discharge illumination systems;
- X-ray equipment;
- High frequency equipment; and
- High voltage wiring and equipment in approved enclosures and energised using a low voltage supply provided adequate precautions have been taken to prevent contact with HV conductors.

Some HV installations, such as those on mine sites, are subject to additional special technical requirements for safety, which may be enforced by the Resources Safety Division of the Department of Consumer and Employment Protection.

### 7.3 Consumer's High Voltage Electrical Installation

#### 7.3.1 Supply

If the HV installation is to be connected to a network, the point of supply and supply voltage will be designated by the network operator in the connection agreement (see also Section 7.4). The consumer's high voltage installation will then commence at the load terminals of the network operator's metering equipment, otherwise it will be at the source of HV supply (e.g. generating plant) at the site. The preferred means of supply is by underground cable terminating on an appropriately rated ring main unit located on the customer's property. The supply will then be at high voltage for customers on the HV tariff, unless the network operator has agreed to a special private HV installation with several widely separated small lightly loaded transformers metered individually at LV.

## 7 High Voltage Installations (continued)

### 7.3.2 Fault Levels

The network operator will provide in writing the maximum prospective fault level at the point of supply under normal operating conditions. This may be lower than the maximum fault level for the connection voltage.

The network operator may permit equipment constructed at less than the maximum prospective fault current, subject to an obligation to upgrade the installation should the fault level subsequently increase to the maximum.

### 7.3.3 Main Switches

The main switch for an installation supplied underground or overhead at high voltage generally shall be a circuit breaker rated for the prospective fault level and fitted with three-phase over-current and earth-fault protection. Alternatively, single or multiple switch fuses, re-closers or pole-top switches with fuses may be used in the following situations covering smaller HV installations, subject to fault level limitations:

- Single or multiple switch fuses (fitted with three phase tripping and operating in all phases simultaneously) may be used to isolate individual transformers with a rating not exceeding 1000 kVA for 6.6 kV/11kV and 1500 kVA for 22kV/33 kV forming part of a consumer's HV installation
- Re-closers (fitted with three-phase over current and earth fault protection but no auto reclose provision) may be used to control the HV aerial supply to a consumer's small HV installation
- Pole top switches with integral drop-out (expulsion) fuses may be used to control an HV aerial supply to individual, pole mounted transformers with a rating not exceeding 315kVA.

The consumer shall ensure the fuses or protection settings in the main switch coordinate with the up-stream protection of the network operator. Changes to settings shall not be made without the network operator's prior approval.

## 7.4 Submission of Proposal

If the installation is to be connected to a network, a high voltage installation design proposal is to be developed, certified as complying with the requirements of the *Electricity (Licensing) Regulations 1991* and the connection agreement by a professionally qualified electrical engineer. The proposal is to be submitted with this certification (in the form of a letter) to the network operator for assessment before equipment is purchased and construction commences.

The following details are to be included in the submission (see also Section 7.5):

- A single line diagram showing all principal components and detailed information such as the transformer voltage levels and winding configurations.
- Loading details, including maximum expected demand, load characteristics, duty cycles, large motor starting details, other disturbing load details and special requirements.
- Where the main switch is one or more HV switch-fuse units (on a common busbar):
  - i. Rated current of all fuses;
  - ii. Rated breaking current of fuses;
  - iii. Make and type of fuses;
  - iv. Current-time characteristic curves.

## 7 High Voltage Installations (continued)

- Where the main switch is a circuit breaker (or similar, such as a re-closer):
  - A control and protection schematic diagram of the incoming circuit breaker(s) or vacuum contactor(s);
  - Make, type, rated load current and rated fault MVA or rated breaking current of incoming circuit breaker(s) or vacuum contactor(s);
  - Details of protection relays used, including:
    - Make and type;
    - Setting range;
    - Characteristic curves drawn for the selected settings;
    - Thermal ratings of input circuit;
    - Tripping and control supply details.
  - Protection current transformer details including:
    - Make and type;
    - Primary current rating;
    - Secondary current rating;
    - CT class;
    - Short time rating;
    - Length and size of secondary circuit wiring;
    - Proposed location.

Note: CTs using primary tapplings for ratio changes are not acceptable.

- Protection details of the next line of protection within the installation to demonstrate safe grading;
- Voltage transformer details, including:
  - Make and type
  - Primary voltage rating
  - Secondary voltage rating(s)
  - Category of performance
  - Rated burden
  - Accuracy class
  - Rated voltage factor and rated duration
- Details of earthing system, including schematic diagram;
- A description of the specific technical standards to which the installation and associated equipment are to conform;
- Operational procedures and details about the person(s) responsible for operating the system.

Protection settings shall be notified to and accepted by the network operator before energisation. Any subsequent change must also be notified to and accepted by the network operator before the change is implemented.

### 7.5 Earthing

Unless otherwise approved by the network operator, HV/LV earthing systems shall be installed in accordance with the requirements of AZ/NZS 3000 and AS 2067.

## 8 Special LV Supply Arrangements

### 8.1 Standby/Emergency Supply

A consumer may install a standby/emergency power supply arranged to operate on failure of the network operator's supply.

Wiring must be arranged and controlled so that it is not possible for the standby supply to be connected to the network operator's distribution system.

### 8.2 Standby Generators

Where an installation has multiple alternative sources of supply incorporating either automatic and or manual switching, appropriate warning labels shall be placed at the source and at the connection point informing operational staff of:

- the existence of each supply;
- type of supply;
- point of isolation;
- type of and location of the switching operation;
- the priority sequence for each supply.

#### 8.2.1 Basic Requirements

Generating sets for emergency or standby supply shall:

- Be installed in accordance with the requirements set out in this document, AS/NZ 3000, AS/NZS 3010.1 and, where relevant, AS/NZS 3009;
- Comply with the relevant requirements of AS 2790;
- Be mechanically and electrically isolated from the network operator's supply;
- Be protected against weather, dampness, fire and over-current.

A changeover switch shall provide isolation between the generating set and the network operator's distribution system. It shall be permanently wired and may or may not incorporate an intermediate "off" position.

If the changeover switch has an intermediate "off" position, it may be used in place of the main switch of the installation. Otherwise, a separate main switch (or switches) must be provided.

Changeover switches must comply with AS 60947.6.1 Automatic Transfer Switches and Equipment.

#### 8.2.2 Single-Phase Generating Sets

##### 8.2.2.1 Stand Alone

Under AS 2790, single-phase generators may have one end of their winding connected to the generator frame, provided that the generator output is protected by a Residual Current Device (RCD). It is important to ensure that the winding to frame/enclosure connection is removed if the RCD is removed or the generating set is connected to an installation with a MEN connection.

## 8 Special LV Supply Arrangements (continued)

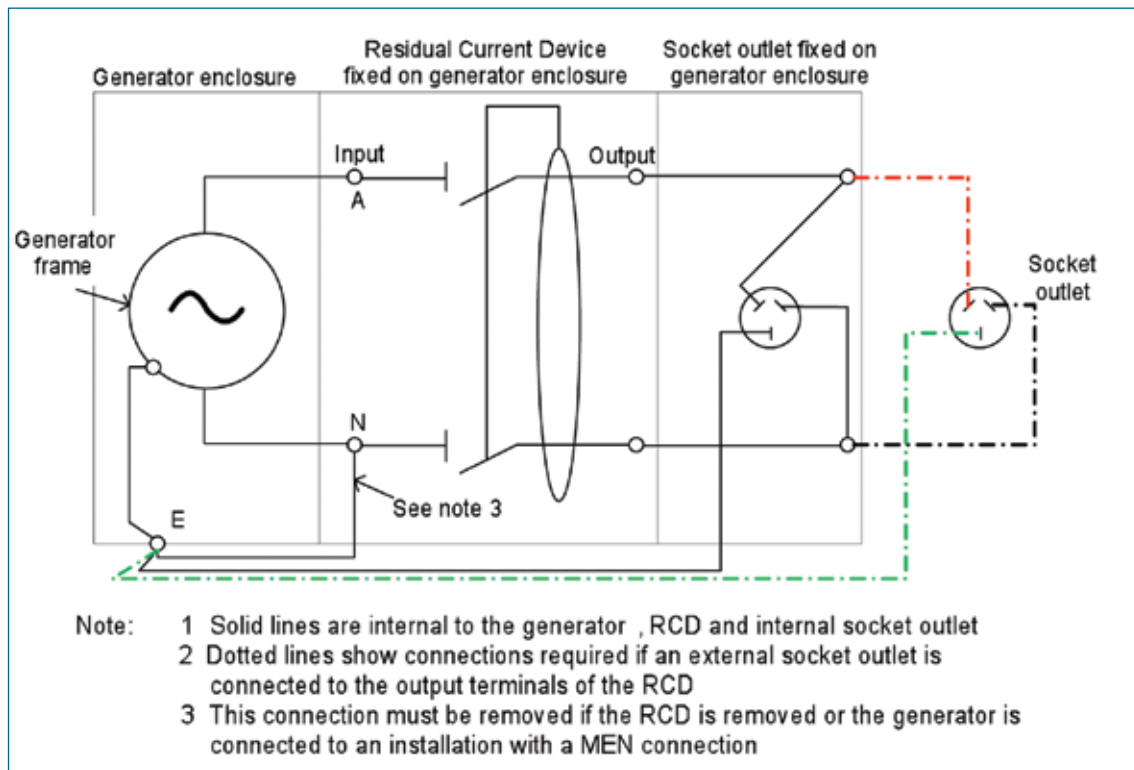

Figure 8.2.2 (a) Single-phase stand-alone generating set

### 8.2.2.2 Connected To Consumers Installations

A generator may be connected to a consumer's installation provided that it cannot be connected to the network operator's distribution system.

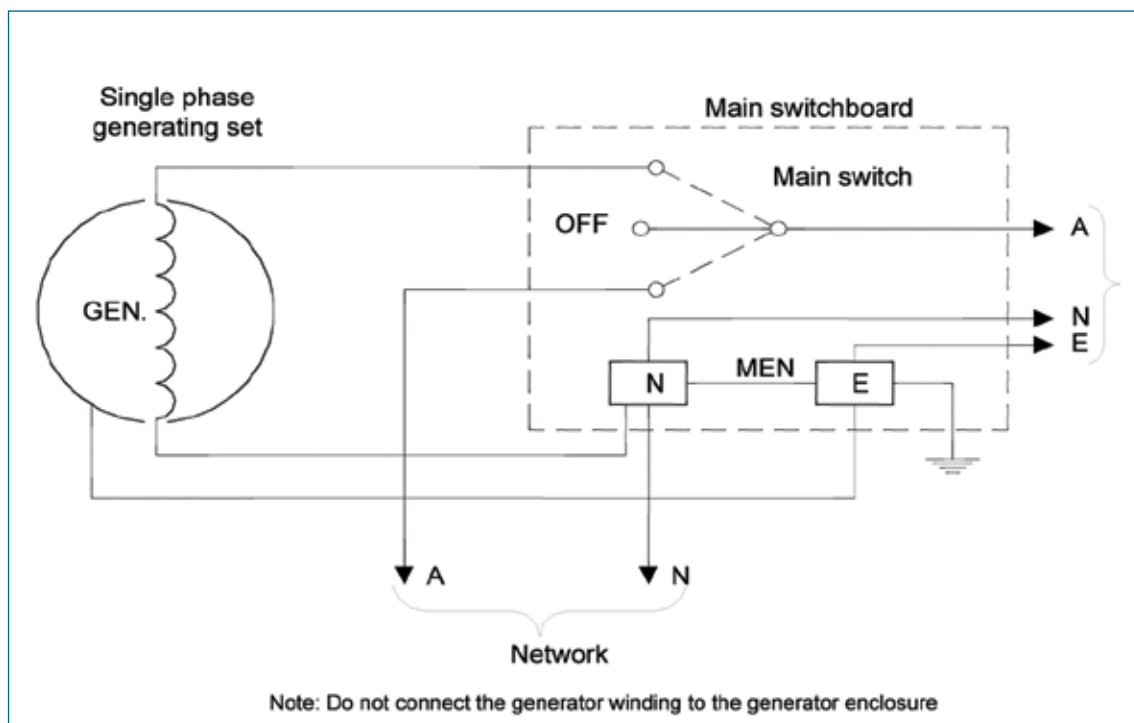

Figure 8.2.2 (b) Single phase generator connected to consumer's installation

## 8 Special LV Supply Arrangements (continued)

### 8.2.3 Three-Phase Generating Sets

#### 8.2.3.1 Connected to Consumers Installation

When connecting a three-phase generating set temporarily or permanently to a switchboard without a MEN connection (e.g. a distribution board located in the same building as the main switchboard), the neutral conductor must be switched and a neutral-earth connection made at the generating set, or alternatively at the distribution board.

#### 8.2.3.2 Connected to a Switchboard with a MEN Connection

When connecting a generating set to a switchboard equipped with a MEN, no neutral earthing connection is to be made at the generating set and the neutral conductor need not be switched.

### 8.3 Common Loads

Two consumers may provide separate supplies to a common load such as a bore installed on the property boundary. Wiring shall be arranged so that only one supply can service the load at any one time and the two supplies cannot be interconnected.

Where a load such as a bore pump is located in one property, the supply to it must originate from the electrical installation in that property. Metering arrangements are available to provide data for determining running cost shares.

If the load straddles a property boundary, appropriately rated socket outlets may be installed on either side of the boundary and supplied from the electrical installations of their respective properties. Alternative means of supply may be submitted to the network operator for approval. A changeover switch arrangement is not acceptable.

The load, or its starter or contactor, may be connected using a flexible cord and plug to either socket outlet. An isolating switch capable of being locked open shall be located adjacent to the load. A robust, easily legible notice shall be fixed on the isolating switch warning that supply may originate from either of two sources. The notice shall be designed to withstand any adverse environmental or climatic effects, including fading caused by ultra-violet radiation.

### 8.4 Short Term Events

The organisers of fetes, circuses, exhibitions, concerts and similar open-air short-term events, shall arrange for an electrical contractor to assess the maximum demand and submit a Preliminary Notice to the network operator. If the demand is such that supply cannot be obtained from a permanent supply point on the property, the Preliminary Notice should request a short-term supply, indicate the estimated maximum demand and state the period for which supply will be needed. If it is proposed to use temporary on-site generators, either to supply the entire demand or to supplement a network operator supply, this too should be mentioned on the Preliminary Notice.

If the event is held outside an area served by a network operator, the Preliminary Notice shall be submitted to the Office of Energy Safety.

The electrical installation shall comply with the requirements of the Wiring Rules and other relevant Australian Standards as listed in Section 12.

Extreme care shall be taken not to create an electrical hazard from two points of supply at one location/site. Where two points of supply are present, the requirements of clause 3.9 shall be applied.



## 8 Special LV Supply Arrangements (continued)

### 8.5 Un-metered Supply

If the network operator and consumer agree, an un-metered underground supply may be made available to certain small installations in public places. In all such cases, the point of supply shall be determined by the network operator and limited to 4.8kW.

Suitable control and protection of the consumer's un-metered supply is required.

For each site with an un-metered supply, the consumer shall submit a location sketch to the network operator's nominated office. The sketch should show the locations of the consumer's structures, and the point of control and protection, with distances from the network operator's equipment and property boundaries.

Where an existing point of supply is to be used it must:

- be on the same side of the road as the customer's equipment;
- be within 25 metres of the customer's equipment;
- be easily visible from the customer's equipment;
- be appropriately rated
- include a label for the un-metered consumer mains.

Only a network operator's authorised personnel may energise un-metered consumer mains.

## 9 Embedded Generators Connected to Networks

### 9.1 Basic Requirements

Embedded power generation installations, including engine-driven, photovoltaic and wind generators intended for normally continuous connection to the external distribution network, must comply with the network operator's requirements and the connection agreement. Such installations must be designed by competent persons who are competent in electricity network engineering and the effects of embedded generation sources on the operation of a distribution network.

The safety of employees working in the installation and on the distribution network must be protected. Consideration must be given to voltage control, power import and export limits, synchronising and islanding, metering, re-closing and fault levels.

Where an installation has multiple alternative sources of supply, incorporating either automatic and or manual switching, appropriate warning labels shall be placed both at the source and at the connection point informing operational staff of:

- The existence of each supply;
- Type of supply;
- Point of isolation;
- Type of and location of the switching device;
- The priority sequence of each supply.

When work is to be performed on a network requiring the isolation of a section containing an embedded generator, the network operator's HV switching programme must incorporate due provision for isolating the relevant network section from all generation sources owned and operated by consumers. The main switch on the main switchboard must isolate the consumer's installation from both the network operator and embedded supplies.

All privately-owned generating installations connected to the network operator's distribution system must comply with all statutory and regulatory requirements, including:

- AS 3010.1 'Electrical installations – supply by generating set Part 1: Internal combustion engine driven set' ;
- These requirements;
- The network operator's requirements for connection of solar and wind generators, either directly in the case of wind, or through an inverter;
- The network operator's technical rules; and
- The network operator's consumer connection agreement.

The network operator may disconnect generating equipment from their distribution system if:

- The continued operation of the equipment is dangerous to the network operator's staff or representatives;
- The continued operation of the equipment is dangerous to the integrity of the network operator's distribution system.

All enquiries about private parallel generation schemes must be directed to the network operator.

## 9 Embedded Generators Connected to Networks (continued)

### 9.2 Safety

#### 9.2.1 General

The generator operator shall ensure that the reliability, integrity and safe operation of the network is not compromised.

The installation shall comply with all safety-related Australian standards and other statutory requirements.

Suitable non-hazardous areas shall be established and maintained within the installation where the network operator's metering, control and data-acquisition equipment may be located and operated satisfactorily. All connections to the network operator's apparatus shall be protected with electrical barriers or other means if these connections originate from or pass through hazardous areas.

#### 9.2.2 Fault Protection

All equipment within the installation shall be adequately protected from any electrical faults in either the installation or the network operator's distribution system.

The fault contributions from the installation at each point of connection shall not exceed the values agreed between the owner and the network operator as stated in the connection agreement.

#### 9.2.3 Interlocks

All switches within the installation capable of interconnecting the generation equipment to the network operator's distribution network shall be adequately interlocked to reduce the risk of an out-of-synchronism fault and to prevent unintended paralleling with the network operator's distribution network feeders.

### 9.3 Protection, Monitoring and Control

#### 9.3.1 Protection Equipment

All protection apparatus should comply with IEC 60255. All protection settings and schemes to the extent that they may affect the network operators system shall be such that satisfactory coordination is achieved with the network operator's protection apparatus.

#### 9.3.2 Islanding

The generator operator must prevent intentional or unintentional islanding. This may occur when the generator continues to energise the network when normal network supply is lost.

The generators shall be disconnected automatically from the network for any of the following events:

- Loss of network stability;
- Loss of network supply;
- Power export exceeding agreed limits;
- Generator pole slip.

The generator may continue to supply the consumer's internal installation during loss of network supply. Reconnection to the network shall not be attempted without the network operator's agreement.

#### 9.3.3 Monitoring and Control

The generator operator shall enable monitoring of the installation and appropriate control of switches by the network operator to safeguard its personnel, the public and the network.

## 10 Construction Sites

A temporary power supply to a construction site shall comply with these Requirements and the Wiring Rules.

Subject to the network operator's distribution system arrangements near the construction site and any specific local requirements, the consumer may utilize one of the following methods for the supply of temporary power:

- Overhead service pole and enclosure;
- Underground portable builder's supply pole and enclosure;
- One or more temporary construction supply switchboards;
- Permanent meter position and installation.

The meter may be installed in an enclosure mounted on a steel post placed near the supply pillar and which can be moved from site to site. Alternatively, the meter may be installed in an enclosure built into the building in its permanent location.

Portable supplies and connections to the network operator's system are the consumer's responsibility. The electrical contractor shall submit appropriate notices to the network operator. On completion of the works, the consumer is to arrange for an electrical contractor to disconnect and remove the portable supply.

For domestic and commercial installations, the permanent main switchboard (or the existing main switchboard if major renovations are planned) may be used as a construction power supply subject to the following:

- The consumers mains and metering equipment are permanently installed;
- The service and consumers mains cables routes are identifiable;
- Point of supply and connection point are clearly marked as live;
- The switchboard and power outlets are safe and do not present a safety hazard ;
- The switchboard is protected from the adverse environmental influences likely to occur during construction (such as dust, moisture and strong vibrations);
- The consumers mains and circuit cabling are provided with appropriate protection against the increased risk of mechanical damage during construction (including warning signs);
- Any electrical work on either the permanent or temporary installation shall be carried out with the supply switched off and secured;
- The temporary power supply wiring is physically and electrically isolated from the permanent installation wiring;
- The permanent installation is not energised until the building work reaches practical completion (and can be secured) and the installation is checked and tested; and
- Prior to the permanent circuits being energised the appropriate notices have been submitted to the network operator

Extreme care shall be taken, regardless of the temporary supply option adopted, not to create an electrical hazard from the presence of two points of supply on one construction site. Where two points of supply are on a site, the requirements of clause 3.9 shall be applied.

Only one temporary power supply connection may be made to a point of supply on a lot. Multiple temporary points of supply are not permitted. All site power must originate from one customer switchboard connected to the point of supply.

## 11 Emergency Conditions

### 11.1 Damaged Installations

A network operator or an electrical contractor may make repairs to reconnect a damaged supply, enabling occupants to use all or designated parts of the installation for a short period while permanent repairs are arranged.

### 11.2 Emergency Disconnection

Under emergency conditions, an electrical contractor or their authorised electrical employee may open the SPD or otherwise isolate the installation from the low voltage electrical supply to ensure their own, occupants' and the public's safety.

Care shall be exercised not to isolate any emergency equipment such as fire-fighting services or evacuation aids.

The installation must then be made electrically safe before the installation can be re-energised. The network operator must be notified immediately upon energisation.

Cables, wiring and apparatus may be installed temporarily to provide rapid restoration of supply. All such installations must be notified to the network operator as soon as practicable after they are energised. A Notice of Completion and Electrical Safety Certificate shall be forwarded to the network operator and installation owner respectively on completion of the permanent repairs.

### 11.3 Defective Main Switch or Boundary Fuse

Should a consumer's main switch, service protection device or boundary fuse become defective, the network operator or authorised electrical contractor may disconnect, and later reconnect, the electrical supply to enable replacement.

### 11.4 Consumers Mains Failure

An electrical contractor may provide an emergency consumers mains to an installation to maintain electricity supply when failure or damage to the permanent main has occurred.

Emergency consumers mains must only remain in service for 14 days (21 days for isolated country districts). The installation of a temporary service shall not create any additional electrical hazard(s). In all cases the temporary consumers mains shall be double insulated along their entire route length and positioned so as to ensure protection from further damage.

The following work shall be undertaken:

- Where the consumers mains switchboard is damaged, deemed unsafe or is unserviceable a panel suitable to house an emergency main switch shall be supplied and installed
- The existing main earth electrode and conductor shall be confirmed as operational or replaced as a part of the temporary repairs; and
- The MEN connection for the temporary arrangement is to be re-made at the consumer's neutral link (not at the network operator's meter or neutral link).

## 11 Emergency Conditions (continued)

As a part of the permanent repairs the electrical contractor shall ensure that:

- Consumers mains comply with the statutory requirements;
- Consumer mains are labelled in accordance with section 3.8;
- Main switchboard complies with the statutory requirements;
- 50 mm rear clearance is provided for existing meter enclosures, provided that a consumers mains cable size of 16 mm<sup>2</sup> is not exceeded;
- Main earth, installation earths and MEN comply with statutory requirements; and
- The installation is electrically safe and free from hazards.

### 11.5 Mains Connection Box Failure

The network operator or authorised electrical contractor may carry out repairs to the mains connection box when failure or damage has occurred. This work must be coordinated with the network operator.

### 11.6 Warning Notices

After installing an emergency supply, the electrical contractor shall leave a warning notice in the main switchboard before leaving the site.

The warning notice shall describe the emergency work installed and provide contact details should it be necessary for anyone to discuss the temporary arrangement with the contractor.

The warning notice should indicate when permanent repairs to the installation are expected to be carried out. The warning notice shall only be removed by an authorised person on completion of the permanent repairs and on submission of the appropriate notices.

## 12 Additional Requirements

### Special Requirements For Installations In Western Australia

Under Regulation 49 of the Electricity (Licensing) Regulations 1991, the requirements set out below, which are additional to or at variance with the Wiring Rules and other Standards, take precedence over those appearing in the Standards and are mandatory.

#### 12.1 Application of Wiring Rules Part 1

Electrical installation designers choosing to use a Wiring Rules Part 1 design and installation solution (rather than apply the deemed to comply requirements of Part 2) must comply with Clause 1.9.4 of the Wiring Rules and the following additional requirements.

Designers must not adopt a Part 1 solution for the following types of electrical installations, which must comply with Part 2 of AS/NZS 3000:2007 and the applicable standard or standards listed later in this Section 12:

- Domestic installations
- Construction and demolition sites
- Medical treatment areas
- Relocatable installations and the site installations to supply them
- Marinas and pleasure craft
- Shows and carnivals.

It is possible however for the designer to request the Director of Energy Safety for a variation or exemption from a requirement in these standards, per regulation 49 (2a) of the *Electricity (Licensing) Regulations 1991*.

#### Design work

Designers must be competent to carry out designs that depart from Part 2 of the Wiring Rules under the provisions of Clause 1.9.4.1. For the purposes of this requirement, the following persons may be considered competent:

- Currently licensed electricians (previously known as electrical installers) with at least 10 years experience in the design and construction of consumer's electrical installations (other than domestic installations) since qualifying, including not less than 5 years design experience in total;
- Electrical designers holding a TAFE Advanced Diploma in Electrical Engineering (or equivalent) and have at least 5 years experience in the design of consumer's electrical installations (other than domestic installations);
- Professional power electrical engineers<sup>1</sup> with at least 5 years experience in the design of consumer's electrical installations (other than domestic installations).

The designer must establish and retain for at least 10 years a folder that contains:

- The document referred to in Clause 1.9.4.2 of the Wiring Rules, which contains the installation owner's or operator's acknowledgment and acceptance that some parts of the installation do not conform to Part 2 of the Wiring Rules; and
- The specific information listed in Clause 1.9.4.3 "Documentation" of the Wiring Rules.

---

<sup>1</sup> Eligible for corporate membership of the Institution of Engineers Australia

## 12 Additional Requirements (continued)

The designer is also required to provide one copy of the folder and contents to the person with overall responsibility for the installation, and a further copy to the person engaged to verify the compliance of the installation.

The designer shall make his/her folder available for examination by an Inspector (Electricity), if requested.

Additionally the designer shall complete Section A of the “Part 1 Design and Verification Certificate”.

### Verification of compliance

Both the design and the construction of the parts of the installation that do not comply with Part 2 of the Wiring Rules are required to be independently assessed to confirm compliance with the requirements listed in Wiring Rules Clause 1.9.4.1 paragraphs (a), (b) and (c), as required by Clause 1.9.4.4.

This verification assessment work may only be carried out by persons who:

- Were not involved in the design of the installation;
- Who do not report to the designer (i.e. They may be part of the same organisation, subject to these constraints)

and who are one of the following: –

- Currently licensed electricians (previously known as electrical installers) with at least 10 years experience in the design and construction of consumer’s electrical installations (other than domestic installations) since qualifying, including not less than 5 years design experience in total;
- Electrical designers holding a TAFE Advanced Diploma in Electrical Engineering (or equivalent) and have at least 5 years experience in the design of consumer’s electrical installations (other than domestic installations);
- Professional power electrical engineers<sup>2</sup> with at least 5 years experience in the design of consumer’s electrical installations (other than domestic installations).

On completion of the verification assessment, the verifier may, if satisfied, complete Section B of the “Part 1 Design and Verification Certificate”.

It is the designer’s responsibility to ensure the verification work is carried out.

When completed by both the designer and verifier, the Certificate must be placed on the project folder referred to above, and retained by the designer for at least 10 years.

---

<sup>2</sup> Eligible for corporate membership of the Institution of Engineers Australia



## 12 Additional Requirements (continued)

### 12.2 Consumers Mains

Single and multi-phase consumer's mains shall have a minimum current-carrying capacity of 32A per phase, except for:

- Single domestic installations, where the minimum current-carrying capacity shall be:
  - Single-phase: 63A
  - Multi-phase: 32A per phase

and

- Multiple installations which incorporate a domestic installation, where the minimum current-carrying capacity shall be:
  - Single-phase: 63A
  - Multi-phase: 63A per phase.

The minimum cable sizes used for consumers mains to domestic premises shall be:

- Single-phase: 10 square millimetres, copper conductors;
- Three-phase: 6 square millimetres, copper conductors.

When calculating voltage drop in an installation, the component of voltage drop across the consumer's mains shall be assessed using the maximum demand of the installation or 80% of the minimum current carrying capacity specified above, whichever is the greater.

Installation designers should bear in mind the steadily growing demand maxima imposed by domestic dwellings, especially with the increasing popularity of split-cycle and central air conditioning. To allow for demand growth, and the possibility of all-electric homes, designers and contractors should consider installing 16 and 10 square millimetre copper conductors respectively for single-phase and three-phase consumers mains.

### 12.3 Current-Carrying Capacity of Cables

Where cables are installed within 100 mm of the ceiling in the roof space of domestic dwellings, they shall be deemed to be either partially or completely surrounded in thermal insulation for the purpose of calculating current-carrying capacity.

If a length of cable not exceeding 150 mm passes through bulk thermal insulation (for example to connect to a lighting point), it shall not be considered as being surrounded by thermal insulation.

Where cables are installed in a manner permitting the free circulation of air around them (for example in a wiring enclosure of adequate dimensions, and in any case, of dimensions not less than 50mm X 100mm), the cables shall not be considered as being surrounded by thermal insulation.

### 12.4 Consumers Mains in Wall Cavities

Insulated and sheathed consumers mains are permissible without enclosure in heavy duty conduit when installed in the cavity of double-brick walls in Western Australia (Clause 3.9.7.1.2).

### 12.5 Equipotential Bonding in Shower Recesses and Bathrooms

Equipotential bonding of the conducting metal reinforcing mesh within concrete floors and walls forming part of a shower recess or bathroom is not required (Clause 5.6.2.5). That is, this is optional in Western Australia.

## 12.6 Earth Electrodes

Electrical contractors and network operators may continue to use earth electrodes complying with AS/NZS 3000:2000 in Western Australian electrical installations until stocks on hand at 30 June 2008 have been used or 31 December 2008, whichever shall first occur. Thereafter, earth electrodes shall comply with Table 5.2 of AS/NZS 3000:2007.

## 12.7 Segregation of Electrical Installations

Except for the following listed circumstances, no part of installation wiring or consumers mains from one lot shall cross into another lot. The exceptions are:

- If electrical zones have been established as required under Section 3.9 of this document, the consumers mains or installation wiring may cross into another lot if they remain within their zone;
- Wiring within common property (see Clause 5.2);
- Consumers mains may cross into an adjacent lot in the vicinity of a service pillar or other similar network operator supply point, if the consumer mains are to be connected into that pillar; and
- If an enterprise operates over adjacent lots and one service supplies all such lots, installation wiring may extend over the lots.

Where a fire-rated barrier separates individual enterprises the electrical services of either enterprise shall not cross such fire rated barriers.

Consumers mains may only cross into road or other reserve when the area they enter is part of a network operator's substation and the consumers mains are to be connected into the substation.

## 12.8 Minimum Cross-sectional Area of Conductors

In domestic installations, conductors for final sub-circuits supplying socket outlets shall have a cross-sectional area of not less than 2.5 mm<sup>2</sup>.

## 12.9 Jointing Consumers Mains

Joints in consumers mains are to be avoided if at all possible. If jointing is unavoidable, electrical contractors may apply to the relevant network operator for approval, and the network operator may approve, jointing by means of a jointing kit approved by the network operator.

## 12.10 Isolated Networks Supplied by Diesel or Gas Power Stations

Towns in remote locations supplied from single diesel or gas-fired power stations may have maximum demand limitations and restrictions on inrush currents imposed by the network operator. Designers and electrical contractors should check with the network operator and refer to Section 13.3 to make sure new installations will be allowed to be connected.

## 12 Additional Requirements (continued)

### 12.11 Applicable Standards

Electrical work must be carried out so as to comply with all parts of the latest version of the following Standards:

<b>A1</b>	AS 2067	Substations and high voltage installations exceeding 1kV a.c.;
<b>A1</b>	AS/NZS 3001	Electrical Installations – Transportable structures and vehicles including their site supplies;
	AS/NZS 3002	Electrical Installations – Shows and Carnivals;
	AS/NZS 3003	Electrical Installations – Patient Treatment Areas of Hospitals and Medical, Dental Practices and Dialysing Locations;
<b>A1</b>	AS/NZS 3004.1	Electrical Installations – Marinas;
<b>A1</b>	AS/NZS 3004.2	Electrical Installations – Recreational Boats Installations;
	AS/NZS 3008.1.1	Electrical Installations – Selection of Cables;
	AS/NZS 3010	Electrical Installations – Generating Sets;
<b>A1</b>	AS/NZS 60079	Explosive Atmospheres; and
	AS/NZS 61241	Electrical Apparatus for Use in the Presence of Combustible Dust.

## 12.12 Part 1 Design and Verification Certificate

### PART 1 DESIGN AND VERIFICATION CERTIFICATE<sup>3</sup>

This form has been approved by the Director of Energy Safety, EnergySafety WA, for use by designers and verifiers of electrical installations which are based on a Wiring Rules “Part 1” design and installation solution, to satisfy requirements detailed in Section 12.1 of the WA Electrical Requirements manual.

**Section A:** To be completed by the designer who wishes to adopt a design solution complying with Part 1 of AS/NZS 3000:2007 Wiring Rules.

**Designer’s Name:**

---

**Designer’s Employer or Business Name:**

---

---

**Project Name:**

---

---

**Project Address:**

---

---

**Brief Description of Project and Proposed Electrical Installation:**

---

---

---

---

---

#### Certification by Designer:

I certify that the electrical installation design described above was designed by me, that I comply with the competence requirements for designers set out in Section 12.1 of the WA Electrical Requirements, and that the installation –

- (a) will satisfy the fundamental safety principles of Part 1 of the Wiring Rules; and
- (b) will result in a degree of safety from physical injury, fire and electric shock not less than that which, in other circumstances, would be achieved by compliance with the particular requirements of the Wiring Rules; and
- (c) will satisfy the other requirements of Clause 1.9 of the Wiring Rules.

**Signature:**

---

**Date:**

---

<sup>3</sup> This form is to be used as a template, shall be typed and may comprise several pages in order to contain all required information.

## 12 Additional Requirements (continued)

**Section B:** To be completed by the verifier.

---

**Verifier's Name:**

---

**Verifier's Employer or Business Name:**

---

**Verifier's Qualifications and Experience:**

---

---

### Certification by Verifier:

I certify that:

- I satisfy the independence and competence requirements for verification work set out in Section 12.1 of the WA Electrical Requirements; and
- The electrical installation design described in Section A has been checked by me; and
- I have satisfied myself that all of the design principles on which the design relies accord with those set out in Part 1 of AS/NZS 3000:2007; and
- In carrying out the checking I have followed an established procedure to ensure all of the principles mentioned in Part 1 have been checked against the design described in Section 1; and
- I am able to verify that the installation –
  - (a) will satisfy the fundamental safety principles of Part 1 of the Wiring Rules; and
  - (b) will result in a degree of safety from physical injury, fire and electric shock not less than that which, in other circumstances, would be achieved by compliance with the particular requirements of the Wiring Rules; and
  - (c) will satisfy the other requirements of Clause 1.9 of the Wiring Rules.

**Signature:**

**Date:**

---

## 13 Network Operators

### 13.1 Introduction

This section lists additional requirements for connections to particular network operators. These requirements include commercial and technical matters not directly related to electrical safety. While consumers must comply with them to obtain a grid connection to the network concerned, the requirements are not made mandatory by regulations.

### 13.2 Western Power – The Southwest Interconnected System

For information pertaining to Western Power’s transmission and distribution network, with details relating to its connection requirements, go to [www.westernpower.com.au](http://www.westernpower.com.au) or for a specific issue contact:

Faults and emergencies, power interruptions, estimated restoration times (24 hours)	13 13 51
Street light faults	1800 622 008 or online form
Technical enquiries (No fault information)	13 10 87
Trees that are close to powerlines (No fault information)	1300 368 733
Self-read meters information and help (No fault information)	1300 551 157
Dial Before You Dig (No fault information)	1100
Media enquiries (No fault information)	1300 139 240
Complaints	13 10 87
Western Power administration – head office (No fault information)	08 9326 4911

Western Power Corporation  
GPO Box L2511 Perth WA 6842  
[www.westernpower.com.au](http://www.westernpower.com.au)

**Details about Western Power’s particular requirements can be found in its Connections Manual, available online at [[www.westernpower.com.au](http://www.westernpower.com.au)].**

## 13 Network Operators (continued)

### 13.3 Horizon Power

For information pertaining to Horizon Power's transmission and distribution networks, with details relating to its connection requirements, go to [www.horizonpower.com.au](http://www.horizonpower.com.au) or for a specific issue contact:

Faults and emergencies, power interruptions, estimated restoration times (24 hours)	13 23 51
Street light faults	1800 264 914 or online form
Complaints/Enquiries – Residential – Business	1800 267 926 1800 737 036
Trees and Powerlines (No fault information)	Please contact your local Horizon Power Office
Dial Before You Dig (No fault information)	1100
Media enquiries (No fault information)	1800 799 745
Horizon Power administration – head office (No fault information)	08 9159 7250

Horizon Power  
PO Box 817, Karratha WA 6714  
[www.horizonpower.com.au](http://www.horizonpower.com.au)

#### Non-interconnected Towns

Horizon Power has a number of remote towns supplied by a single power station. It is important that load connected to these power stations is balanced. In some locations there are special restrictions on the size of an installation's total load and of individual motors that may be connected to the local power supply. These special restrictions are listed below:

Note: It may be possible to connect single phase loads of up to 63A in towns listed as 32A above, but only with Horizon Power's prior written approval. Conditions relating to the installation of motors exceeding 20kW rating shall be determined by Horizon Power. Prior written approval for connection must be obtained.

### 13 Network Operators (continued)

Town	Max size of a single phase installation	MAX MOTOR SIZE 3 Phase DOL
Ardyaloon	15A	3kW
Beagle Bay	15A	3kW
Bidyadanga	15A	3kW
Broome	32A	
Camballin	15A	3kW
Carnarvon	32A	
Cue	32A	
Denham	32A	
Derby	32A	
Esperance	32A	
Exmouth	32A	
Fitzroy Crossing	32A	
Gascoyne Junction	15A	3kW
Halls Creek	32A	
Hopetoun	32A	
Kununurra	32A	
Lake Argyle	32A	
Laverton	32A	
Leonora	32A	
Lombadina/Djarindjin	15A	3kW
Marble Bar	32A	
Meekatharra	32A	
Menzies	15A	3kW
Mount Magnet	32A	
Murchison	15A	3kW
Nullagine	15A	3kW
Onslow	32A	
Sandstone	15A	3kW
Warmun	15A	3kW
Wiluna	32A	
Wittenoom	15A	3kW
Wyndham	32A	
Yalgoo	15A	3kW



## 13 Network Operators (continued)

### Under Frequency Load Shedding and Demand Side Management

Horizon Power shall require the fitting of electronic control devices (ECDs) to new air-conditioning unit control systems, that enable disconnection from the network during a power system disturbance. The customer equipment will return to normal operation following the disturbance. The purpose of the ECD is to improve power system reliability by:

- Reducing system load so that power may be restored more quickly; and
- Reducing system peak load to match the available generation capacity.

Horizon Power will also consider the retrofitting of this control equipment.

## 13.4 Rio Tinto Iron Ore

### 13.4.1 Introduction

The following requirements are particular to Rio Tinto Iron Ore's (network operator) electricity network, which covers the towns of Dampier, Wickham, Tom Price, Paraburdoo and Pannawonica, and their interconnecting transmission system.

### 13.4.2 Definitions

Authorised person: Any person appointed in writing by an authorised employee of the network operator for the purpose of working on network operator equipment.

### 13.4.3 General Requirements

Application for a new connection or substantial increase in connected load must be made on the standard form(s) obtained from the network operator, so that the capacity of the network to supply the load can be investigated. Refer to section 13.5.7 for contact information.

Significant expenses should not be incurred as a result of a new connection or substantial load increase prior to receipt of a written approval to any such application.

Connection to Rio Tinto Iron Ore's distribution system shall only be made by a network's officer or other authorised person.

### 13.4.4 Earthing System

Two earthing systems are used:

- Direct earthing by laid up network operator's earth;
- MEN system.

The MEN system is to be used for all new or upgraded electrical installations unless advised otherwise by the network operator.

## 13 Network Operators (continued)

### 13.4.5 Service and Metering Equipment

The network operator will supply revenue meters for installation by a Network Officer or other authorised person.

Meter test blocks shall be fitted to all CT metered installations.

Commercial tariff meters are to be installed in a separate pad-lockable cubicle complete with viewing window.

Where it is necessary to lock switchboard enclosures containing service and metering equipment, only Yale 490-25 MK PI cam locks or padlocks which incorporate a Rio Tinto Iron Ore master key pattern will be accepted.

### 13.4.6 Emergency Conditions

Access to the network operator's equipment such as supply pillars and pole mounted protective devices shall be by Network Officer or other authorised persons only.

### 13.4.7 Contact Information

Emergencies (including electrical accidents and shocks) or supply interruptions.

**Phone 1800 992 777**

For electricity account enquiries, including new connections and substantial increase in connected load applications.

**Phone 1800 992 777**

Alternatively applications can be downloaded from:

<http://www.infrastructurecentral.riotinto.com/>

Electrical contractors may obtain specific supply rulings, notice submission details or other technical information by contacting an Inspectorate Officer on (08) 9143 3233 during normal office hours.

## 13 Network Operators (continued)

### 13.5 BHP Billiton Limited

#### 13.5.1 Introduction

The following requirements are particular to BHP Billiton Leinster Nickel Operation electricity networks, and are monitored by the Leinster Supply Authority.

#### 13.5.2 Definitions

No additional definitions

#### 13.5.3 General Requirements

##### 13.5.3.1 Connection Process

The electrical contractor must contact the Leinster Supply Authority.

##### 13.5.3.2 Supply Arrangements

The electrical contractor or consultant responsible for the project design shall submit details to the Leinster Supply Authority of any new connections that increase the maximum demand of an existing or new installation.

The method of connection and details of requirements will be location dependent.

##### 13.5.3.3 Boundary Fuses

The Leinster Supply Authority must be consulted about the location and type of service protection device (SPD) required. SPDs generally will be in accordance with the requirements of Section 6.8.

#### 13.5.4 Overhead Supplies

The Leinster Supply Authority must be consulted about where overhead supplies may be used.

#### 13.5.5 Underground Supplies

No additional requirements.

#### 13.5.6 Service And Metering Equipment

The Leinster Supply Authority must be consulted about the types of metering systems in Leinster.

#### 13.5.7 High Voltage Installations

The Leinster Supply Authority must be consulted concerning supplies at high voltage, which are normally 33 kV.

#### 13.5.8 Special LV Supply Arrangements

The Leinster Supply Authority must be consulted about any special LV supply arrangements of the kind mentioned in Section 8.

#### 13.5.9 Private Generators Connected To Networks

Connection of private generators to the network generally will be permitted. Individual applications will be considered on their merit and only for specific reasons.

## 13 Network Operators (continued)

### 13.5.10 Supply To Construction Sites

The Leinster Supply Authority must be consulted about any supply to construction sites mentioned in Section 10.

### 13.5.11 Supply Under Emergency Conditions

To make an installation safe under emergency conditions, an electrical contractor may remove the SPD fuse(s) and subsequently replace them when the emergency condition is cleared. The Leinster Supply Authority must be notified as soon as practicable after removal of the SPD fuse(s) and will indicate at the time if replacement of the fuse(s) may be performed by the contractor.

### 13.5.12 Special Requirements For Installation In WA

No additional requirements.

### 13.5.13 General Information

An electrical contractor or consultant who requires:

- specific information from the Leinster Supply Authority;
- specific information for submission of Preliminary Notices or Notices of Completion;
- a Supply Ruling;
- a Regulatory/Inspection Ruling,

is required to contact the Leinster Supply Authority at:

The Leinster Supply Authority Electrical Inspector's Office  
PO Box 22  
LEINSTER WA 6437  
Tel: (08) 9037 9327  
Fax: (08) 9037 9128







