



Department of Planning,  
Lands and Heritage



We're working for  
Western Australia.



10 April 2024

# R-Codes

## Residential Design Codes

# Explanatory Guidelines

These guidelines supplement  
*State Planning Policy 7.3 Residential Design Codes Volume 1*  
and are to be read in conjunction with that policy.

2019 R-Codes  
(incorporating amendments gazetted on 24/05/2019)

The Department of Planning, Lands and Heritage acknowledges the traditional owners and custodians of this land. We pay our respect to Elders past and present, their descendants who are with us today, and those who will follow in their footsteps.

#### Disclaimer

This document has been produced by the Department of Planning, Lands and Heritage on behalf of the Western Australian Planning Commission. Any representation, statement, opinion or advice expressed or implied in this publication is made in good faith and on the basis that the Government, its employees and agents are not liable for any damage or loss whatsoever which may occur as a result of action taken or not taken, as the case may be, in respect of any representation, statement, opinion or advice referred to herein. Professional advice should be obtained before applying the information contained in this document to particular circumstances.

© State of Western Australia

Published by the  
Western Australian Planning Commission  
Gordon Stephenson House  
140 William Street  
Perth WA 6000

Locked Bag 2506  
Perth WA 6001

Published May 2019  
website: [www.dplh.wa.gov.au](http://www.dplh.wa.gov.au)  
email: [info@dplh.wa.gov.au](mailto:info@dplh.wa.gov.au)

tel: 08 6551 8002  
fax: 08 6551 9001  
National Relay Service: 13 36 77

This document is available in alternative formats on application to the Department of Planning, Lands and Heritage Communications Branch.



Contents

## Contents

<b>1. Purpose, format and application of these guidelines</b>	<b>4</b>	<b>4. Design elements of the R-Codes Volume 1 – Context</b>	<b>14</b>	<b>5. Design elements of the R-Codes Volume 1 – Streetscape</b>	<b>27</b>
<b>2. Administration of the R-Codes</b>	<b>7</b>	<b>General</b>	<b>14</b>	<b>General</b>	<b>27</b>
<b>2.1 R-Codes approval process</b>	<b>7</b>	<b>Specific design elements</b>	<b>16</b>	<b>Specific design elements</b>	<b>27</b>
2.1.1 Grouped and multiple dwelling approval	7	<b>4.1 Street setback</b>	<b>16</b>	<b>5.1 Street surveillance</b>	<b>28</b>
2.1.2 Single house approval	7	4.1.1 Street setbacks – Part 5 of R-Codes Volume 1	18	<b>5.2 Street walls and fences</b>	<b>29</b>
2.1.3 Judgement of merit	8	<b>4.2 Lot boundary setbacks</b>	<b>19</b>	5.2.1 Street walls and fences – Part 5 of R-Codes Volume 1	29
<b>2.2 Accompanying information</b>	<b>8</b>	4.2.1 Lot boundary setbacks – Part 5 of R-Codes Volume 1	20	<b>5.3 Sight lines</b>	<b>30</b>
2.2.1 Application forms and decision notices	8	<b>4.3 Open space</b>	<b>21</b>	<b>5.4 Setback of garages and carports – Part 5 of R-Codes Volume 1</b>	<b>31</b>
2.2.2 Consultation with decision-maker	9	4.3.1 Open space – Part 5 of R-Codes Volume 1	21	<b>5.5 Garage width – Part 5 of R-Codes Volume 1</b>	<b>31</b>
2.2.3 Preparation of necessary plans	9	<b>4.4 Building height</b>	<b>22</b>	<b>5.6 Appearance of retained dwelling – Part 5 of R-Codes Volume 1</b>	<b>32</b>
<b>2.3 Neighbour consultation</b>	<b>10</b>	4.4.1 Building height – Part 5 of R-Codes Volume 1	23		
2.3.1 Principles of consultation	11	<b>4.5 Site area – Part 5 of R-Codes Volume 1</b>	<b>24</b>		
2.3.2 Consultation procedure	11	<b>4.6 Communal open space – Part 5 of the R-Codes Volume 1</b>	<b>26</b>		
<b>3. Application of the R-Codes</b>	<b>12</b>				
<b>3.1 Format of the R-Codes Volume 1</b>	<b>12</b>				
<b>3.2 Design elements of R-Codes Volume 1</b>	<b>12</b>				
<b>3.3 What drives good design outcomes?</b>	<b>13</b>				



## Contents

<b>6. Design elements of the R-Codes Volume 1 – Site planning and design</b>	<b>33</b>	<b>7. Design elements of the R-Codes Volume 1 – Building design</b>	<b>45</b>	<b>9. Local planning framework</b>	<b>63</b>
General	33	General	45	<b>9.1 Scope of local planning policies, structure plans and local development plans</b>	<b>63</b>
Specific design elements	33	Specific design elements	45	9.1.1 Context	64
<b>6.1 Outdoor living areas</b>	<b>34</b>	<b>7.1 Visual privacy</b>	<b>46</b>	9.1.2 Streetscape	64
6.1.1 Outdoor living areas – Part 5 of R-Codes Volume 1	34	7.1.1 Visual privacy – Part 5 of the R-Codes Volume 1	50	9.1.3 Site planning and design	64
<b>6.2 Landscaping</b>	<b>35</b>	<b>7.2 Solar access for adjoining sites</b>	<b>53</b>	9.1.4 Building design	64
<b>6.3 Parking</b>	<b>37</b>	7.2.1 Solar access for adjoining sites – Part 5 of the R-Codes Volume 1	56	9.1.5 Special purpose dwellings	64
6.3.1 Parking – Part 5 of R-Codes Volume 1	38	<b>7.3 Outbuildings</b>	<b>58</b>	9.1.6 Regional exceptions	65
<b>6.4 Design of car parking spaces</b>	<b>39</b>	<b>7.4 External fixtures</b>	<b>59</b>	<b>9.2 Local planning policy proforma</b>	<b>65</b>
<b>6.5 Vehicular access</b>	<b>40</b>	<b>7.5 Utilities and facilities</b>	<b>59</b>	<b>9.3 The R-Codes and schemes</b>	<b>65</b>
6.5.1 Vehicular access – Part 5 of R-Codes Volume 1	41	<b>8. Design element for Part 5 of the R-Codes Volume 1 – Special purpose dwellings</b>	<b>60</b>	9.3.1 Local planning strategies	66
<b>6.6 Site works</b>	<b>42</b>	Specific design elements	60	9.3.2 Local planning schemes	66
<b>6.7 Retaining walls</b>	<b>43</b>	<b>8.1 Ancillary dwellings</b>	<b>60</b>	9.3.3 Density control	66
6.7.1 Retaining walls – Part 5 of the R-Codes Volume 1	43	<b>8.2 Aged or dependent persons’ dwellings</b>	<b>61</b>	9.3.4 Changes in housing density	66
<b>6.8 Stormwater management</b>	<b>44</b>	<b>8.3 Single bedroom dwellings</b>	<b>62</b>	9.3.5 Restricted coding	67
<b>6.9 Pedestrian access – Part 5 of R-Codes Volume 1</b>	<b>44</b>			9.3.6 Expanded or dual coding	67
				9.3.7 Housing in non-residential zones	68
				9.3.8 Short-term accommodation	68
				9.3.9 Residential buildings	68
				9.3.10 Heritage matters	68
				9.3.11 Residential precincts or localities	68
				9.3.12 Special control areas	69
				<b>Appendices</b>	
				<b>Appendix 1: R-Codes Volume 1 application and determination forms</b>	<b>70</b>
				<b>Appendix 2: Local planning policy prepared via State Planning Policy 7.3 – Residential Design Codes Volume 1</b>	<b>72</b>
				<b>Appendix 3: Local development plan proforma</b>	<b>74</b>



## 1 Purpose, format and application of these guidelines

[Return to contents page](#)

### 1 Purpose, format and application of these guidelines

[Purpose](#)

[Format](#)

[Application](#)

*These explanatory guidelines (the guidelines) are prepared by the Western Australian Planning Commission (WAPC), as outlined under [clause 1.5 of the State Planning Policy 7.3 Residential Design Codes Volume 1 \(R-Codes Volume 1\)](#) and may be amended from time-to-time.*

*Throughout this document, words written in [underlined blue](#) print have a corresponding definition listed in Appendix 1 of the R-Codes Volume 1 and link electronically directly to this definition. Where a defined word occurs a number of times on a page or section, only the first occurrence is so marked and linked. Electronic links to R-Code Volume 1 clauses and figures are also marked in this manner.*

### Purpose

The purpose of these guidelines is to explain and assist interpretation and application of the R-Codes Volume 1.

The R-Codes are introduced by reference into a [scheme](#) and it is a requirement for all [residential development](#) to comply with the R-Codes. The guidelines are designed to be read with the R-Codes Volume 1 provisions to provide clarification and to guide proponents, [decision-makers](#) and other relevant stakeholders regarding the design, assessment and implementation of residential development in Western Australia.

Together with other state planning policies and WAPC operational (development control) policies, the R-Codes also guide the assessment of residential subdivision proposals by the WAPC, although they are not intended to prescribe subdivision design and standards.

They provide advice and guidance to assist interpretation and assessment of proposals against the [design principles](#) and/or [deemed-to-comply](#) provisions set out in part 5 of the R-Codes Volume 1.

Where particular matters of a local nature demand particular planning/development controls, it is intended that the R-Codes should be complemented by [local planning policies](#) adopted under a scheme, specific provisions of the scheme, [local development plans](#) and/or [structure plans](#). However, such variations and policies should be limited to matters relevant to a particular locality (refer to Part 7 of the R-Codes Volume 1).

### Format

Section 2.0 of the guidelines outlines the administration provisions of the R-Codes Volume 1 (parts 1-4) and comprises the approval process, application requirements and neighbour consultation. Appendix 1 sets out suggested examples of R-Codes Volume 1 approval application and determination forms that may be used by the decision-maker.

Section 3.0 of the guidelines explains how the R-Codes Volume 1 are applied. The R-Codes Volume 1 provide a performance approach to control residential development through the application of design elements and provisions. Deemed-to-comply provisions provide a straightforward means for [development](#) to comply with principles and objectives. Design principles enable an alternate pathway for innovative development proposals to be considered.

Sections 4.0 – 7.0 of the guidelines include explanations of the following R-Codes Volume 1 design elements:

- Context (section 4.0);
- Streetscape (section 5.0);
- Site planning and design (section 6.0), and
- Building design (section 7.0)

General guidelines relating to the R-Codes Volume 1 are provided within the above design elements. Following this, guidelines relating to specific part 5 provisions are provided. This format is illustrated and explained on page 5.



## 1 Purpose, format and application of these guidelines

Return to contents page

### 1 Purpose, format and application of these guidelines

Purpose

Format

Application

General guidelines relating to development proposals

# R-Codes

Residential Design Codes of Western Australia Explanatory Guidelines

Return to contents page

6 Design elements of the R-Codes Volume 1 – Site planning and design

General

Specific design elements

- 6.1 Outdoor living areas
- 6.2 Landscaping
- 6.3 Parking
- 6.4 Design of car parking spaces
- 6.5 Vehicular access
- 6.6 Site works
- 6.7 Retaining walls
- 6.8 Stormwater management
- 6.9 Pedestrian access – Part 5 of R-Codes Volume 1

### 6 Design elements of the R-Codes Volume 1 – Site planning and design

Page 41

**General guidelines**

The location of the crossover should be provided in response to the nature of the **street(s)** onto which the **development** fronts. If there is more than one **street frontage** (including rear lanes), the vehicle access should be provided onto the street that carries the lowest volumes of traffic. However, the crossover should also be provided in a location that provides clear sight lines in both directions along the street, is separated as far as possible from any intersection, does not impact on on-street services such as public transport stops, accounts for posted speed limits, and is designed in accordance with any built-up median.

Vehicles can be slowed by creating a clearly different environment at the entry of the **site**. This can be achieved through the use of texture in the paving surface, creating a perceived narrowing of the carriageway, and use of planting and short access legs to limit the ability for cars to pick up speed across the area. Through appropriate design, the use of speed humps can be avoided.

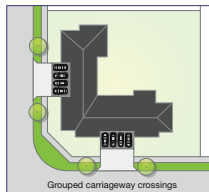

Grouped carriageway crossings

Car parking is provided in a manner that increases the proportion of the frontage that is dedicated to vehicular access.

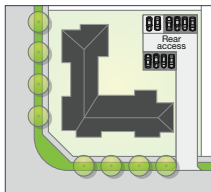

Rear access

Car parking is located away from view of the street and accessed via a single consolidated access point.

**Figure 54: Consolidate vehicular access points to reduce impact on streetscape.**

**Part 5 only**

**6.5.1 Vehicular access – Part 5 of R-Codes Volume 1 (Clauses 5.3.5 of R-Codes Volume 1)**

Vehicular access is required to include **driveways** of an adequate width to allow for the movement of vehicles as per 5.3.5 of the R-Codes Volume 1.

A driveway width of 3m is adequate for driveways serving four **dwelling**s or less but a minimum of 4m that is designed to allow for two-way access is required for driveways serving five or more dwellings.

Note that a driveway is also required to be **setback** 0.5m from a side **lot boundary** for purposes not limited to stormwater management, **landscaping** and utilities. The total minimum width for vehicle access may therefore be required to be at least 4m or 5m to allow 0.5m on either side of a driveway between two lot boundaries.

For a proposed **battleaxe lot**, where vehicle access is within the battleaxe leg, the proposal will also be subject to the requirements of **Development Control Policy 2.2 Residential Subdivision**.

Guidelines relating to part 5 development proposals only



## 1 Purpose, format and application of these guidelines

[Return to contents page](#)

### 1 Purpose, format and application of these guidelines

[Purpose](#)

[Format](#)

[Application](#)

Section 8, [Special purpose dwellings](#) sets out the guidelines for [ancillary, aged and dependent persons](#) and [single bedroom dwellings](#) which only relate to Part 5 of the R-Codes Volume 1.

Section 9.0 outlines the [local planning framework](#) under part 7 of the R-Codes Volume 1. Guidance is provided regarding the relationship between the R-Codes Volume 1 and the local planning framework and the implementation of the R-Codes Volume 1 within the framework. This section outlines the scope of [local planning policies](#), [local development plans](#) and [structure plans](#). Appendix 2 outlines the preferred format for a local planning policy and Appendix 3 sets out the preferred format for a local development plan which may be used by the decision-maker.

### Application

The guidelines do not provide quantitative measures additional to the R-Codes Volume 1. They simply identify a range of issues requiring consideration and identify some common design techniques to ameliorate the impacts of a [development](#) or improve the responsiveness of the design. The guidelines also outline the design elements that should be taken into account when determining whether an application meets the intent of the [design principles](#). A development outcome, particularly in higher density and mixed use environments, is [site](#) specific and will often not rely on a standard approach or measure. The guidelines seek to clarify the use of discretion by [decision-makers](#); however, it is not possible to cover all scenarios and contexts.

The figures, diagrams and images in these guidelines seek to illustrate certain design tools that are considered effective in achieving the intent of the design principles. They should not be taken to be [deemed-to-comply](#) design criteria as the design tools outlined are not appropriate in all situations and therefore, simply replicating the design approaches will not automatically result in the design principles being met for a particular development proposal.



## 2 Administration of the R-Codes

[Return to contents page](#)

### 2 Administration of the R-Codes

- 2.1 R-Codes approval process
- 2.2 Accompanying information
- 2.3 Neighbour consultation

### 2.1 R-Codes approval process

#### [Part 2 of the R-Codes Volume 1](#)

Land zoned residential or similar under a [scheme](#), will be subject to an R-Code which outlines the intended scale and form of the [development](#) that should occur on that land. The full range of R-Codes that relate to these guidelines are set out in [table 1](#) of the R-Codes Volume 1.

Proponents are required to demonstrate, to the satisfaction of the [decision-maker](#), that proposals meet all relevant R-Code provisions. The process to obtain R-Codes Volume 1 approval is illustrated in a [flowchart](#) in clause 2.1 of the R-Codes Volume 1 which is provided as a guide.

#### 2.1.1 Grouped and multiple dwelling approval

Under many [schemes](#), planning approval is required for the development of [grouped](#) or [multiple dwellings](#).

Grouped dwellings under all R-Codes and multiple dwellings in areas with an R-Code less than R40 are to be assessed against Part 5 of the R-Codes Volume 1.

Multiple dwellings in areas with an R-Code of R40 or greater are to be assessed against the R-Codes Volume 2 – Apartments (R-Codes Vol.2).

Any application that involves a mixture of both multiple and grouped dwellings is to be assessed against a combination of R-Codes Volume 1 part 5 and the R-Codes Volume 2, with the land apportioned to each [dwelling](#) type for the purposes of calculating minimum [site area](#) per dwelling and [plot ratio](#).

An application that includes a mixed use component will require an exercise of judgment when assessed by the [decision-maker](#). The R-Codes are only intended to be applied in regard to the residential component of the [development](#), with the [design principles](#) targeting the interface between the residential and non-residential uses to minimise the potential for the different uses on site to impact upon the other(s).

#### 2.1.2 Single house approval

The R-Codes Volume 1 do not require planning approval for [single houses](#) that comply with relevant [deemed-to-comply](#) provisions under Part 5 of the R-Codes Volume 1 unless:

- (a) otherwise required by a [scheme](#); or
- (b) the lot area is under 260m<sup>2</sup> and not subject to a [local development plan](#) or [structure plan](#).

#### R-Codes approval

The [decision-maker](#) must confirm that a proposal complies with the R-Codes Volume 1 prior to the issue of a building permit.

A building permit determination should not seek to impose planning conditions, and a building permit should not be refused on planning grounds. This can create delays and result in invalid (ultra-vires) decisions.

Where a [single house](#) proposal does not meet one or more of the [deemed-to-comply](#) provisions of the R-Codes Volume 1 (and therefore seeks to apply one or more [design principles](#)), an application for planning approval or alternative application must be submitted, assessed and determined before a building permit is issued. Appendix 1 includes

application and determination forms that decision-makers can use for single house proposals.

The R-Codes Volume 1 do not specifically address physical construction requirements, energy efficiency or internal arrangements of [buildings](#). These are matters controlled by the Building Code of Australia (BCA).

#### Planning approval under a scheme

A number of [schemes](#) require planning approval for the development of a [single house](#). This provision overrides the R-Codes Volume 1 and accordingly planning approval must be obtained, before making an application for a building permit.

#### Single houses on small lots

Due to potential design difficulties and other planning issues that arise in the design and development of [dwellings](#) on small [lots](#), planning approval has previously been required under the R-Codes Volume 1 for [single houses](#) on lots of less than 350m<sup>2</sup>. This has now been reduced to 260m<sup>2</sup> having regard to the minimum and average [site area](#) per [dwelling](#) requirements set out in [table 1](#) of the R-Codes Volume 1 for R30 and R35 respectively.

This is in keeping with current housing trends and declining average lot sizes and to address adverse impacts upon affordable housing placed by unnecessary additional cost burden on purchasers. There is also now demonstrated practice and increased technical capacity to build on small lots.

In addition, the R-Codes Volume 1 recognise that in many greenfield [sites](#), Liveable Neighbourhoods may require the preparation of [local development plans](#) (also known as detailed area plans) for small



## 2 Administration of the R-Codes

[Return to contents page](#)

### 2 Administration of the R-Codes

- 2.1 R-Codes approval process
- 2.2 Accompanying information
- 2.3 Neighbour consultation

lots. Where this more detailed planning has been undertaken, issues associated with the smaller lot size are considered to have already been dealt with. Therefore, planning approval under the R-Codes Volume 1 for single houses is not required on lots less than 260m<sup>2</sup> if in accordance with an approved [structure plan](#) and/or local development plan. The future review of Liveable Neighbourhoods will consider the need to stipulate a small lot area.

### 2.1.3 Judgement of merit

The R-Codes Volume 1 have been prepared to provide, via the [deemed-to-comply](#) provisions, a straightforward pathway to approval. Where a proposal does not achieve the deemed-to-comply provisions and therefore seeks to apply one or more [design principles](#), the approval of the [decision-maker](#) is required for those matters only.

Where any deemed-to-comply provision is not met, an applicant must seek approval from the decision-maker for their proposal against specific design principles. The decision-maker may only refuse an application that meets deemed-to-comply provisions where it does not meet more stringent [scheme](#) or [local planning policy](#) provisions which apply.

All R-Codes Volume 1 provisions (with the exception of the [site area](#) requirements set out in [table 1](#)) are open to the exercise of judgement based on the design principles and the relevant objectives for that element.

In determining the proposal, the [decision-maker](#) should seek to adopt a consistent approach taking into account:

- the design principle relating to the matter for which approval is sought;
- the relevant provisions of the scheme; and
- the relevant contents of a local planning policy prepared in accordance with the R-Codes.

Referral of a development application to Council or to other parties (such as design review panels) should be limited and only necessary where the officer of the decision-maker does not have delegated authority or is not satisfied that the proposal satisfies the relevant design principles and objectives, and the officer's judgement requires confirmation.

The types of design issues which might often warrant referral to other parties for their comment may relate to subjective aspects of amenity, privacy, overshadowing, height or [building](#) mass, or perhaps where alternative access is proposed, matters likely to result in off-site impacts or where there may be other information not available or known to the applicant.

Where a decision-maker refuses such an application or imposes conditions that are considered unreasonable to the applicant, a right of review may be lodged with the State Administrative Tribunal, according to the provisions of the *Planning and Development Act 2005*.

## 2.2 Accompanying information

### [Part 3 of the R-Codes Volume 1](#)

### 2.2.1 Application forms and decision notices

A proponent is required to submit an application for approval of a proposal (as required by the [scheme](#)) either by submitting a planning application form provided under a scheme or by the use of an alternative application form as required by the [decision-maker](#). Usually in the case of [single houses](#), as outlined in section 2.1.2 of the guidelines, the R-Codes Volume 1 approval form included in Appendix 1 may be used.

Specific information and application fees are required to accompany the application form to enable determination by the decision-maker. This information would describe not only the proposed [development](#) but also, where appropriate, the relationship of the development to neighbouring development. Good design begins with a clear understanding of the [site](#) and its immediate surroundings and planning context.

Part 3 of the R-Codes Volume 1 sets out an application information matrix that identifies the types of information required to support certain application types, recognising that some applications, by their nature, require more information than others. Information required in the matrix is identified as information that:

- (a) shall be provided to support the application as denoted by "I" in the matrix;
- (b) may be required to be provided, at the discretion of the decision-maker, dependent on the nature of an application, as denoted by "O" in the matrix; or





## 2 Administration of the R-Codes

[Return to contents page](#)

### 2 Administration of the R-Codes

- 2.1 R-Codes approval process
- 2.2 Accompanying information
- 2.3 Neighbour consultation

(c) may be required for an application which proposes to apply one or more design principle(s), as denoted by “\*” in the matrix.

While most of the required information is common to all applications, there are additional specific information requirements, for example, where a proposal is for an [aged](#) or [dependent persons’](#) dwelling development, or it affects a [heritage place](#), or it requires the preparation of a [landscaping](#) plan, or may result in overlooking or overshadowing of an [adjoining property](#).

### 2.2.2 Consultation with decision-maker

The [decision-maker](#) can advise the proponent regarding the relevant [local planning framework](#) considerations as well as the R-Codes requirements and assessment fees that apply to any particular proposal.

The decision-maker may also indicate where a proposal does not meet [deemed-to-comply](#) provisions and hence requires justification in terms of the relevant [design principles](#) of the R-Codes Volume 1. This will enable a proponent to amend the proposal or prepare the justification prior to submitting an application to avoid unnecessary determination delays.

In those instances where a proposal has the potential to adversely affect the amenity of a neighbouring property, for example by overlooking or overshadowing, the decision-maker can advise which neighbours may need to be consulted and the advertising process to be followed, including the design elements or other matters for which neighbour comment is being sought.

### 2.2.3 Preparation of necessary plans

An application includes development drawings, comprising floor plans, [setbacks](#), elevations, cross-sections, heights and exterior finishes of the proposed [development](#), as required by [clause 3.2.5](#) and the application information matrix of the R-Codes Volume 1.

Unless determined otherwise by the [decision-maker](#), a site analysis plan should be prepared in parallel with the development drawings in accordance with [clause 3.2.3](#) of the R-Codes Volume 1. A site analysis plan should show any

existing development on the [site](#), including any [outbuildings](#) and other development (such as swimming pools, [pergolas](#) etc.) as well as relevant information pertaining to adjacent properties and street features. The information that should be included on a site analysis plan is shown in figure 1.

It is desirable to prepare a separate proposed development site plan as required by [clause 3.2.4](#) of the R-Codes Volume 1 as shown in figure 2 (page 10), although it would be acceptable to combine the two plans where all the required information is provided and is legible.

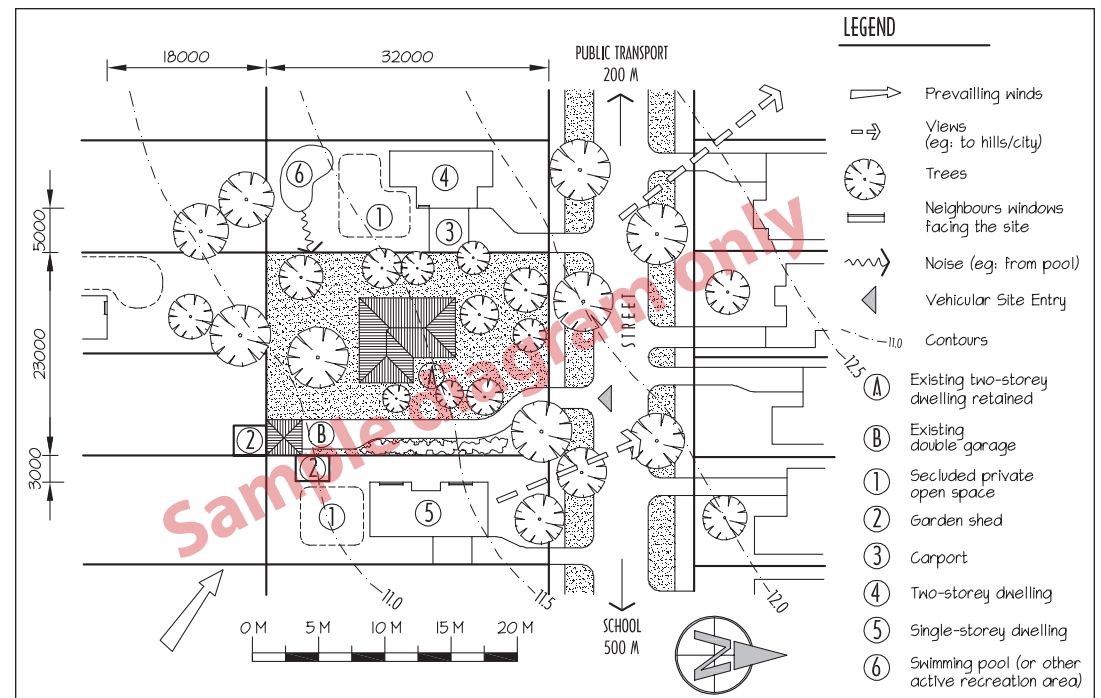

Figure 1: Example of site analysis plan.

## 2 Administration of the R-Codes

[Return to contents page](#)

### 2 Administration of the R-Codes

- 2.1 R-Codes approval process
- 2.2 Accompanying information
- 2.3 Neighbour consultation

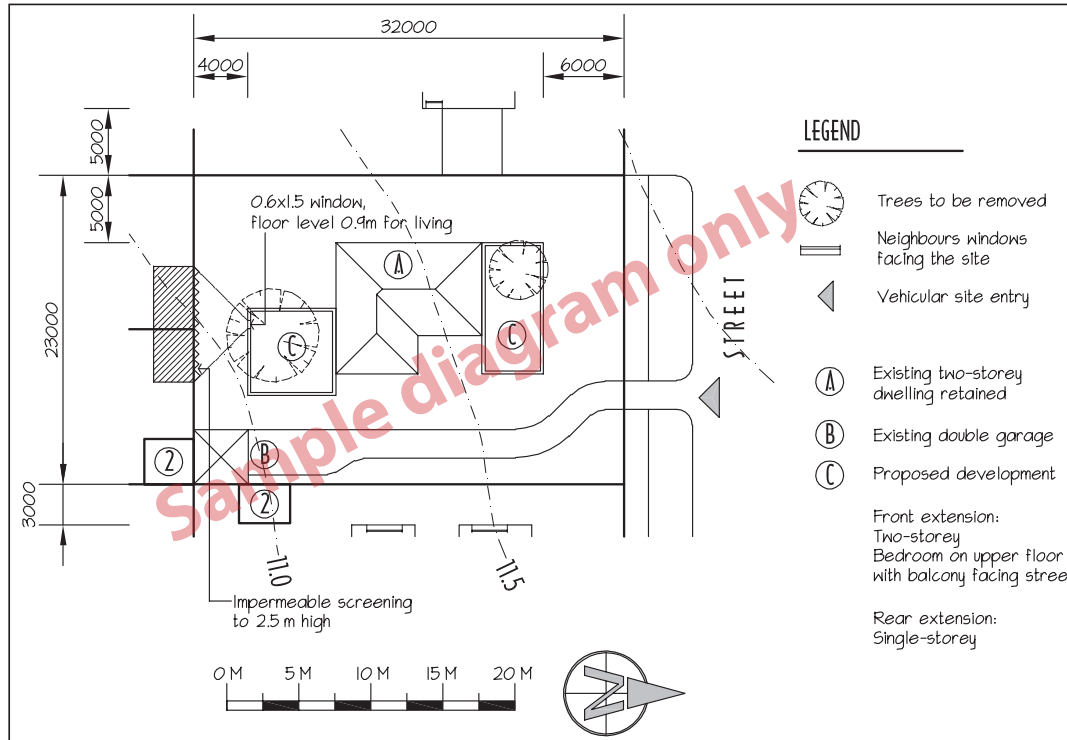

**Figure 2:** Example of proposed development site plan.

### 2.3 Neighbour consultation

#### [Part 4 of the R-Codes Volume 1](#)

In respect to the R-Codes, the prime purpose of neighbour consultation is to seek comment about a nominated design component(s) of the proposal and how it may affect the neighbour where:

- (a) a proposal is to be judged against one or more [design principles](#) of the R-Codes Volume 1; and
- (b) a possible impact and/or reduction of the amenity of adjoining owners and occupiers may result.

In some [schemes](#), consultation may be required irrespective of compliance of the proposal.

Neighbour consultation is not to shift or replace the responsibility of the [decision-maker](#) to make decisions.

A proposal that meets [deemed-to-comply](#) provisions of the R-Codes Volume 1 would not require neighbour consultation unless required by the scheme and/or a [local planning policy](#).

A proposal that applies a design principle but would not, in the opinion of the decision-maker, cause potential impact upon the amenity of adjoining owners and occupiers, would not require neighbour consultation.

Where a proposal includes a combination of design principles and deemed-to-comply provisions, only those aspects of the proposal that address a design principle and may cause a potential impact on the amenity of adjoining owners and occupiers would require neighbour consultation.



## 2 Administration of the R-Codes

[Return to contents page](#)

### 2 Administration of the R-Codes

- 2.1 R-Codes approval process
- 2.2 Accompanying information
- 2.3 Neighbour consultation

### 2.3.1 Principles of consultation

Proponents should consider the likely impacts of their proposal on neighbouring properties and residents. Referral of applications for neighbour comment should clearly indicate the particular aspects of the proposal requiring comment, and restrict comment to those matters only.

It is usually more productive, as well as courteous, to advise neighbours of [development](#) proposals as far in advance as possible and, where necessary, negotiate outcomes that are acceptable, before a formal application is lodged.

Formal consultation as initiated by the [decision-maker](#) should be confined to those matters where the decision-maker is called on to exercise judgement of merit in relation to an aspect of the development that affects adjoining/adjacent property.

The opinions of affected adjoining owners and occupiers can inform, but cannot be a substitute for, the exercise of professional judgement by the decision-maker. In weighing up the contents of submissions, the assessment needs to consider the [deemed-to-comply](#) provisions and the [design principles](#) before drawing assessment on the impact of the development in reference to the R-Codes Volume 1 objectives and any other relevant [local planning framework](#) requirements.

### 2.3.2 Consultation procedure

The suggested consultation procedure is as follows:

- To advise proponents to first discuss proposals with adjoining owners and occupiers who may be affected by the [development](#) before the proposal is finalised and submitted to the [decision-maker](#). This is particularly important for areas where a proposal does not meet [deemed-to-comply](#) requirements and thus, is required to address the relevant [design principle](#) of the R-Codes Volume 1.
- For all consultation to be clearly and adequately documented and reported.
- In inviting comment, it should be made clear on which aspects of the proposal comment is being sought and that the decision-maker's decision depends on the exercise of its judgement. It does not follow that the decision-maker should or will automatically agree with neighbours' comments.
- For [adjoining property](#) owners and occupiers to be given the opportunity to understand the proposal by inspecting the plans and afforded reasonable time to provide comments on the proposal, should they wish to do so.
- Where a proposal is likely to affect more than the immediate neighbours, to invite comment on the proposal via alternate communication methods, for example, notice in the form of a sign erected on the [site](#) and/or in the local newspaper.

- To provide the proponent with a summary of all submissions received, with an opportunity to respond prior to the decision-maker considering the application. The submissions summary should not contain the submitter's name, address or contact details.

Where the decision-maker deems it necessary to consult with [adjoining property](#) owners and occupiers, and no prior informal consultation has taken place, it is appropriate that the invitation to comment on the proposal come from the decision-maker itself.

In order to avoid unnecessary delays in the determination of the proposal, it is desirable that the decision-maker delegate to its officers the power to determine whether an application requires consultation and which owners and occupiers should be the subject of consultation.

Should an applicant choose to undertake neighbour consultation instead of the decision-maker, the applicant is required to provide proof that they have provided notification of the proposal to neighbours in the form of a posting receipt via registered post. The decision-maker needs to verify that the landowner/occupier of property for which notification is required, has been notified and the nature of comments sought relevant to the proposal. The decision-maker should use its rate-payer database or the electoral role, to ensure the landowner/occupier of the property is the same as the registered post receipt addressee.



## 3 Application of the R-Codes

[Return to contents page](#)

### 3 Application of the R-Codes

- 3.1 Format of the R-Codes Volume 1
- 3.2 Design elements of the R-Codes Volume 1
- 3.3 What drives good design outcomes?

### 3.1 Format of the R-Codes Volume 1

Part 5 of the R-Codes Volume 1 contain development provisions that provide the basis for controlling the design, siting and [development of residential development](#).

Part 5 and associated tables and figures apply to:

- all [single houses](#);
- all [grouped dwellings](#); and
- [multiple dwellings](#) in areas with a coding of less than R40.

Part 5 of the R-Codes Volume 1 are arranged to ensure proposals acknowledge and respond to the surrounding development context. They are divided into four design elements, being:

- context
- streetscape
- site planning and design
- building design

Part 5 includes an additional design element – special purpose dwellings.

### 3.2 Design elements of the R-Codes Volume 1

These design elements start at the broad contextual level and then specifically focus on the detailed [building](#) and [site](#) layout requirements. The provisions require detailed consideration of context and the attributes that characterise and define the locality.

Each of these design elements has:

- **objectives** which outline the desired outcomes for the design element in terms of the quality of the building, its fit-for-purpose use and relationship with its surroundings;

- **design principles** which are listed in the left-hand column and provide guidance on matters which must be addressed and demonstrated by a proposal and the means of achieving the objective/s. These are not intended to be limiting or prescriptive but encourage proponents to address each design issue; and
- **deemed-to-comply** development provisions which are listed in the right-hand column and are related to the [design principle](#) and objectives. Proposals are assessed in terms of their ability to comply with these provisions.

This is illustrated in the example found in Part 5 of the R-Codes Volume 1 below.

#### 5.3 Site planning and design

##### Objectives

- (a) **Landscape** design should optimise function, useability, privacy and social opportunity, equitable access, respect neighbours' amenity and provide for practical establishment and maintenance.
- (b) To ensure access to housing provides for security, safety, amenity and legibility to on-site car parking areas and footpaths for residents and visitors.
- (c) To ensure each **development** makes a contribution to a streetscape by respecting the natural topography for each **site, adjoining properties** and the amenity of the locality.
- (d) To reduce the economic, environmental and social impacts associated with **site** works to facilitate housing **development** (e.g. via soil disturbance, groundwater impact and water use for dust suppression).

Example

Design principles	Deemed-to-comply
<i>Development demonstrates compliance with the following design principles (P)</i>	<i>Development satisfies the following deemed-to-comply requirements (C)</i>
<b>5.3.1 Outdoor living areas</b>  P1.1 <b>Outdoor living areas</b> which provide spaces: <ul style="list-style-type: none"> <li>• capable of use in conjunction with a <b>habitable room</b> of the <b>dwelling</b>;</li> <li>• open to winter sun and ventilation; and</li> <li>• optimise use of the northern aspect of the <b>site</b>.</li> </ul> P1.2 <b>Balconies</b> or equivalent <b>outdoor living areas</b> capable of use in conjunction with a <b>habitable room</b> of each <b>dwelling</b> , and if possible, open to winter sun.	C1.1 An outdoor living area to be provided: <ul style="list-style-type: none"> <li>• in accordance with <b>Table 1</b>;</li> <li>• behind the <b>street setback area</b>;</li> <li>• directly accessible from a <b>habitable room</b> of the <b>dwelling</b>;</li> <li>• with a minimum length and width dimension of 4m; and</li> <li>• to have at least two-thirds of the required area without permanent roof cover.</li> </ul> C1.2 Each <b>multiple dwelling</b> is provided with at least one <b>balcony</b> or the equivalent, opening directly from a <b>habitable room</b> and with a minimum area of 10m <sup>2</sup> and minimum dimension of 2.4m.

5.3 Site planning and design



## 3 Application of the R-Codes

[Return to contents page](#)

### 3 Application of the R-Codes

- 3.1 Format of the R-Codes Volume 1
- 3.2 Design elements of the R-Codes Volume 1
- 3.3 What drives good design outcomes?

The R-Codes Volume 1 assume that the land which is the subject of a proposal is able to adequately accommodate [development](#) without significant departure from the deemed-to-comply provisions of the R-Codes Volume 1. While the deemed-to-comply provisions do allow for a straightforward pathway to approval, the use of the design principles rather than the deemed-to-comply provisions should not be viewed as non-compliance, but rather an alternative design outcome.

The R-Codes Volume 1 also recognise that there may be circumstances where a more appropriate housing design can result by applying a [design principle\(s\)](#) which will better suit development of the [site](#) rather than achievement of the [deemed-to-comply](#) provisions; for example, due to shape, slope or aspect.

The R-Codes Volume 1 contemplate that a proposal may either address all design principles, all deemed-to-comply provisions, or a combination of the two (which is most likely), depending on the design element and the proposed design response.

If the proponent wishes to have a proposal assessed against a combination of both the design principles and the deemed-to-comply provisions, the proponent is required to clearly identify where the design proposal does not address either the deemed-to-comply or design principle provisions.

Where a proposal applies the design principles, it is the responsibility of the proponent to demonstrate how the proposed design meets the design principle(s), the objectives of the R-Codes Volume 1 plus any local objectives and requirements which specifically relate to the site and its context.

### 3.3 What drives good design outcomes?

Our cities, towns and suburbs are becoming more complex. The need to accommodate greater diversity in land use, housing types and transport modes requires a more sophisticated approach and increased focus on good design.

The acknowledgement of the following factors assists successful achievement of good design outcomes for [residential development](#) (including residential uses within a [mixed use development](#)):

- **Vision** – Providing more intensive, varied and sustainable urban form is an explicit policy objective in Western Australia. This will require change in strategic locations over time. For good design outcomes to be achieved there needs to be clearly articulated vision as to the location and desired character of urban transformation areas.
- **Relationship to setting** – A [dwelling](#) type that is appropriate in one setting, such as existing suburban development, may not be appropriate in another setting, such as an [activity centre](#). Consideration of the character and local environment of a place is required and takes into account any future changes that may be proposed to an area.
- **Commercial viability versus neighbourhood character** – There must be a balance between maximising commercial viability and achieving a built form that complements the local neighbourhood character.

- **Consultation** – Early consultation with relevant parties to establish a collaborative atmosphere allows for issues to be identified which in turn allows for better mitigation options and mutually beneficial outcomes.
- **Balancing conflicting design elements** – In many circumstances, compromises will need to occur when two design elements have conflicting outcomes, such as providing highlight windows instead of standard height windows to prevent overlooking yet still allowing ventilation and daylight.
- **Flexibility** – While [deemed-to-comply](#) standards of the R-Codes Volume 1 provide a reasonable pathway to achieve the desired built form outcome, there are often situations where concessions to the controls, via application of the design principles, may achieve a better built form outcome.



## 4 Design elements of the R-Codes Volume 1 – Context

[Return to contents page](#)

### 4 Design elements of the R-Codes Volume 1 – Context

General

Specific design elements

4.1 Street setback

4.2 Lot boundary setbacks

4.3 Open space

4.4 Building height

4.5 Site area  
– Part 5 of R-Codes Volume 1

4.6 Communal open space – Part 5 of the R-Codes Volume 1

### General

#### [\(Clause 5.1 of the R-Codes Volume 1\)](#)

Physical and natural attributes combine to define the character of an area. It is important that [development](#) maintains and enhances local or neighbourhood character. In situations where areas are undergoing transition, good design will reflect the future desired character of the area as outlined in the [local planning framework](#). However, if no future desired character has been set out, development should respond to the existing character of the area, in terms of its scale, function and visual appearance.

#### Consideration of the surrounding development context

Most suburban streetscapes are open, with direct views along the [street](#), and generally direct (although sometimes screened) views across the street between houses. This visual relationship is shaped by the width of the roadway and verges, the public and private landscapes with the edges defined by [buildings](#) as they are set back from the street and each other. The heights and [setback](#) of buildings, area dedicated to private [landscaping](#), and access [driveways](#) all contribute to the open, suburban appearance and function. There is an expectation that the built form is not the dominant feature of the suburban landscape.

Residential character is created by the relationship between landscape and built form. The visual character may be described as suburban and is shown in Figure 3.



**Figure 3:** Example of suburban character.



**Figure 4:** Example of urban character.

An urban context is expected to have less of the open characteristics of a suburban area. Where an area of housing is dense, for example in many inner city and inner suburban precincts, the urban landscape is visually dominated by the built form and is shown in Figure 4. The buildings are set close to, and sometimes right on, the street alignment, and close to or abutting each other.

However, prevailing patterns of [development](#) in Western Australia, with greater use of medium density codes used in both infill and greenfield areas, results in something of a hybrid between the open suburban and traditional closed urban characters. In these medium urban areas, care should be taken to protect elements of setback and [open space](#) to maintain the difference in context between high and medium urban density areas.



## 4 Design elements of the R-Codes Volume 1 – Context

[Return to contents page](#)

### 4 Design elements of the R-Codes Volume 1 – Context

General

Specific design elements

- 4.1 Street setback
- 4.2 Lot boundary setbacks
- 4.3 Open space
- 4.4 Building height
- 4.5 Site area – Part 5 of R-Codes Volume 1
- 4.6 Communal open space – Part 5 of the R-Codes Volume 1

### Context analysis

Notwithstanding whether the [development](#) is occurring in a manner that is consistent with existing character or in a manner consistent with the desired character, a context analysis assists in establishing an appropriate design response, refer to figure 5.

### Neighbourhood context

The neighbourhood context analysis considers the proposed [development site](#) within the planning framework for the locality. The analysis should outline the zoning and land use of the development site and the surrounding neighbourhood, as outlined within the [local planning framework](#).

At this level the appropriateness of a particular [development](#) proposal for the [site](#) can be identified, based upon the existing and likely future development in the locality.

### Street context

The [street](#) context analysis establishes the existing character and features of the immediate area. Key considerations include:

- distribution and mix of land uses;
- subdivision pattern;
- scale and setting of adjoining built form;
- impacts from adjoining land uses;
- [building](#) articulation, materials and finishes;
- street design and proportions; and
- public spaces.

### Site context

The [site](#) context analysis investigates the parameters of the site and the relationship with the [buildings](#) on the adjoining [lots](#) and opportunities for improving functionality and performance. Key considerations include:

- building [setbacks](#) and separation;
- active and passive areas on adjoining lots;
- [open space](#) and [landscaping](#);
- orientation;
- existing vegetation and topography;
- views from public places; and
- location of existing on-street car parking.

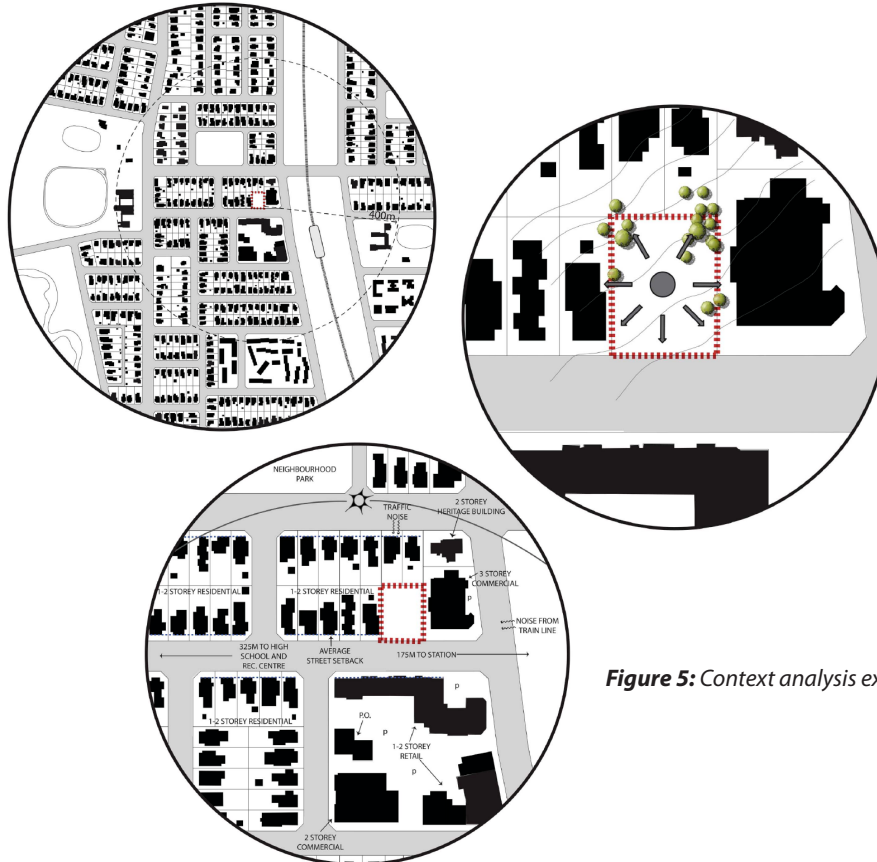

Figure 5: Context analysis example.



## 4 Design elements of the R-Codes Volume 1 – Context

[Return to contents page](#)

### 4 Design elements of the R-Codes Volume 1 – Context

General

Specific design elements

4.1 Street setback

4.2 Lot boundary setbacks

4.3 Open space

4.4 Building height

4.5 Site area  
– Part 5 of R-Codes  
Volume 1

4.6 Communal open  
space – Part 5 of the  
R-Codes Volume 1

### Specific design elements

([Clause 5.1 of the R-Codes Volume 1](#))

This generic design element deals with significant factors that affect and contribute to the context of the [development](#). The following are the design elements of part 5 of the R-Codes.

- 4.1 Street setback;
- 4.2 Lot boundary setback;
- 4.3 Open space; and
- 4.4 Building height.
- 4.5 Site area; and
- 4.6 Communal open space.

There is a strong relationship between elements of context and elements of streetscape; some streetscape elements are encompassed within context here, others are dealt with specifically in design element 5.2 Streetscape of the R-Codes Volume 1, respectively.

### General guidelines

#### 4.1 Street setback

([Clause 5.1.2 of the R-Codes Volume 1](#))

The urban design presumption is for the [street setback area](#) to be free from [buildings](#) and structures, enabling a clear view to and from the [street](#). This provides a comfortable and secure relationship and transition between public and private space.

From a social point of view, the street setback area and how it is developed and managed allows for comfortable communication and interaction between residents, neighbours and passers-by or callers who may not be known to the occupants. This creates the opportunity for casual and safe interaction to enhance a sense of community and safety.

At the same time, an open [setback](#) area provides for mutual surveillance between the street and building, enhancing security for the building (and its occupants) and for people passing by.

From a visual point of view, an open setback area provides a more attractive setting for the building. The [street setback](#) should also provide, depending on the location of essential services, adequate clearances from, and access to, essential services for reasons of safety and utility.

The same principles apply to [communal streets](#) and [rights-of-way](#) that provide the [frontage](#) to [dwellings](#).

There will, of course, be exceptions, principally where the [street](#) is an arterial road carrying significant volumes of traffic.

#### Frontage streets

[Street setback areas](#) are an integral part of the streetscape and are fundamental to the amenity and particular character of residential localities. They may perform a number of different, but complementary roles:

- continuity of the streetscape;
- a visual setting for the [dwelling](#);
- a buffer against noise and general activity on the public [street](#);





## 4 Design elements of the R-Codes Volume 1 – Context

[Return to contents page](#)

### 4 Design elements of the R-Codes Volume 1 – Context

General

Specific design elements

4.1 Street setback

4.2 Lot boundary setbacks

4.3 Open space

4.4 Building height

4.5 Site area  
– Part 5 of R-Codes Volume 1

4.6 Communal open space – Part 5 of the R-Codes Volume 1

#### General guidelines

- privacy for the dwelling;
- visual connection to the street, its users and to neighbours;
- space for car parking and access; and
- a transition zone between the public street and private dwelling.

These considerations apply particularly to public [streets](#) to influence orientation of the main frontage to [dwellings](#) as it presents to the street. Similar principles apply to [communal streets](#), and [rights-of-way](#) used to provide frontage to dwellings. [Secondary](#) or side streets may also function in this way.

#### Side or secondary streets

Different streetscape characteristics usually occur on [secondary](#) or side [streets](#), with the street alignments formed by the long side boundaries of corner [lots](#). These are characterised by side fences or [walls](#) rather than open gardens, and a small [setback](#) to the building.

In many cases these streetscapes are being altered by urban redevelopment and infill, by the subdivision of corner lots, creating new frontages to the side street. Where this happens, similar considerations to those for setbacks to [frontage](#) streets will apply although there will be scope for common-sense rationalisation between existing houses which create the character of the street and infill [development](#).

The setback area should be open but with a reduced setback for practical and streetscape reasons. [Private open space](#) may be located to one side of the [building](#) rather than a narrow strip along the rear.

#### Rights-of-way as streets

Many [rights-of-way](#), especially in older areas, are becoming increasingly important, not only to provide vehicle access to the rear of properties, but in the case of subdivision also to provide [frontage](#) access for new buildings. In some cases the rights-of-way may become dedicated public roads or [streets](#). In other cases they will remain as private rights-of-way to provide secondary access. Inevitably, the scale and character of these streetscapes are different, and a lesser [setback](#) is often appropriate, consistent with the narrowness of the rights-of-way and the principal function for resident access rather than for local through traffic.

#### Communal streets

[Communal streets](#) are those created as part of a [grouped dwelling development](#). They are in private ownership common to a number of [dwellings](#), whose owners are also responsible for maintenance. As semi-public spaces, they share some of the characteristics and roles of public streetscapes and share the need for design to address issues of visibility and security. Clear demarcation between private space and the communal street is important, as is the need for a transition area, a buffer against noise and glare and privacy for dwellings. However, the reduced scale, communal nature and use, and often informality of layout of communal streets, calls for a less rigid approach to [setbacks](#) for dwellings (refer to [figure 2d](#) of the R-Codes Volume 1).

#### Measurement of street setback distances

The impact of a [building](#) on the streetscape is most commonly observed from the standpoint of a person moving parallel to the street alignment. Accordingly, the [street setback](#) is measured at right angles to the [street](#) alignment.



## 4 Design elements of the R-Codes Volume 1 – Context

[Return to contents page](#)

### 4 Design elements of the R-Codes Volume 1 – Context

General

Specific design elements

4.1 Street setback

4.2 Lot boundary setbacks

4.3 Open space

4.4 Building height

4.5 Site area  
– Part 5 of R-Codes Volume 1

4.6 Communal open space – Part 5 of the R-Codes Volume 1

Part 5 only

### 4.1.1 Street setbacks – Part 5 of R-Codes Volume 1

[\(Clause 5.1.2 of the R-Codes Volume 1\)](#)

#### Appropriate street setback distances

In the case of new residential areas, the desirable [street setback](#) distance is often fixed as an integral part of the subdivision, for example as part of [structure plan\(s\)](#) or [local development plan\(s\)](#).

In the case of established residential areas with valued streetscapes, it will usually be the case that there is a consistent pattern of street setbacks. In these cases, new [development](#) should closely conform to the established pattern. Where the pattern varies, a [setback](#) mid-way between that of the [buildings](#) on either side may be appropriate.

In established areas, it may be desirable for the [decision-maker](#) to stipulate setbacks for a particular area by setting them out in the [local planning framework](#). The R-Codes Volume 1 street setback requirements apply in all other cases.

The manner in which street setbacks may be reduced is illustrated in [figure 2a](#) of the R-Codes Volume 1. This includes a provision allowing a street setback reduction of up to 50 per cent, providing the area of building (including any [carport](#) or [garage](#)) forward of the required street setback line is compensated for by an equal or greater area of [open space](#) behind the street setback line.

The prime purpose of this provision is to only allow a reduced [setback](#) from the [street](#) where this will create flexibility of design to achieve the design objectives for the area, and lead to a more varied and interesting streetscape. [Figures 2a](#) and [2b](#) in the R-Codes Volume 1 illustrate situations where portions of the [dwelling](#) may intrude into the street setback provided there is a positive relationship with adjacent dwellings and the streetscape.

#### Other structures

Other than [carports](#) and [garages](#) (subject to [clause 5.2.1](#) of the R-Codes Volume 1), no substantial structures are allowed in [street setback areas](#). Structures that may be allowed are:

- low fences or [walls](#), which are the subject of separate consideration;
- [landscape](#) or sculptural structures, ornamental features designed to enhance the relationship between [street](#) and dwelling; and
- appropriately scaled archways or gateways, provided they are in character with the streetscape.

In addition, architectural features, including [balconies](#), [porches](#), chimneys and open [verandahs](#), may be acceptable as minor incursions into the [setback](#) area, the criterion being that the main setback line is not unduly interrupted. Those minor incursions, where they do not exceed the limits prescribed at [clause 5.1.2 C2.4](#), should not be taken into consideration when calculating average setback requirements.



## 4 Design elements of the R-Codes Volume 1 – Context

[Return to contents page](#)

### 4 Design elements of the R-Codes Volume 1 – Context

General

Specific design elements

4.1 Street setback

4.2 Lot boundary setbacks

4.3 Open space

4.4 Building height

4.5 Site area  
– Part 5 of R-Codes Volume 1

4.6 Communal open space – Part 5 of the R-Codes Volume 1

### General guidelines

#### 4.2 Lot boundary setbacks

([Clause 5.1.3 of the R-Codes Volume 1](#))

Boundary [setbacks](#), other than [street setbacks](#), serve several objectives:

- to ensure adequate daylight, direct sun and ventilation for [buildings](#) and the open space associated with them;
  - to moderate the visual impact of building bulk on a neighbouring property;
  - to ensure access to daylight and direct sun for [adjoining properties](#); and
  - to assist with the protection of privacy between adjoining properties.
- Related clauses in the R-Codes Volume 1 which deal with some aspects of these objectives are:
- [clause 5.1.6](#) building height;
  - [clause 5.4.1](#) visual privacy; and
  - [clause 5.4.2](#) solar access for adjoining sites.

#### Calculation of boundary setbacks

The distance required to set back a [wall](#) from a boundary is a function of the height and length of the wall and whether there are [major openings](#) in the wall.

It is first necessary to consider whether an opening falls within the definition of a major opening under the R-Codes Volume 1. The intention of the definition is to restrict clear glazing that would impact on privacy. A 'highlight window' is also excluded from the definition of major opening; a window is considered a highlight if it has a minimum sill height of 1.6m. The intention is for the window glazing to be a minimum of 1.6m above floor height to avoid overlooking.

The [setback](#) requirements are set out in [tables 2a](#) and [2b](#) or [table 5](#) and [figure 4e](#) of the R-Codes Volume 1. Tables 2a and 2b should be used for walls less than 10m in height and in the case of intermediate height and length measurements, the nearest higher setback should be used.

The matters to take into account in establishing the height and length of walls for the purpose of determining side setbacks is illustrated in [figure series 3](#) and [4](#) of the R-Codes Volume 1.

The setback at any particular point depends on the wall height at that point rather than the average wall height. This means that a wall which varies in height (in relation to the [natural ground level](#)) could require a varying setback along its length. Height of walls and buildings is calculated from the lowest point of natural ground level at the boundary adjacent to that point of the wall on the building.

#### Buildings built up to lot boundaries

Buildings built up to [lot boundaries](#) are subject to the provisions of [clause 5.4.1](#) for overlooking and [clause 5.4.2](#) in relation to solar access (overshadowing). The [deemed-to-comply](#) provisions adopt a conservative or risk-averse approach in recognition that the [decision-maker](#) would not be required to make a technical judgement.

Where a wall is built on the boundary, the surface of the wall facing a neighbour should be finished to the satisfaction of the decision-maker.

The decision-maker may adopt a [local planning policy](#) to vary the provisions in respect of boundary walls to require less or more exacting standards or require consultation with adjoining neighbours as a prerequisite.



## 4 Design elements of the R-Codes Volume 1 – Context

[Return to contents page](#)

### 4 Design elements of the R-Codes Volume 1 – Context

General

Specific design elements

4.1 Street setback

4.2 Lot boundary setbacks

4.3 Open space

4.4 Building height

4.5 Site area  
– Part 5 of R-Codes Volume 1

4.6 Communal open space – Part 5 of the R-Codes Volume 1

Part 5 only

### 4.2.1 Lot boundary setback – Part 5 of the R-Codes Volume 1

[\(Clause 5.1.3 of the R-Codes Volume 1\)](#)

#### Basis of setback controls

The boundary setback provisions of the R-Codes Volume 1 have been designed, as closely as possible, to reflect the approach that a proponent would adopt when siting and designing a building.

The overarching principles which need to be considered in assessment of designs are:

- the taller and longer a wall adjacent to a boundary is, the further it should be set back;
- [walls](#) with no windows, with windows only to non-habitable rooms or with highlight windows, can be permitted to be closer to boundaries than those walls with windows to [habitable rooms](#) or with [balconies](#);
- single storey walls are not usually problematic in terms of impact on [adjoining properties](#);
- short walls built up to boundaries are often preferable to long walls set back a short distance;
- with the increasing tendency for infill [development](#) and more flexible design approaches, any distinction between rear and side boundaries has become largely obsolete;
- community acceptance of walls built up to side or rear boundaries is greater in medium-to high-density areas compared with low density areas;
- [outdoor living areas](#), whether in the form of decks, [verandahs](#), balconies or raised terraces, have an impact at least equal to, and usually greater than, those of indoor living areas, and hence ought to be treated similarly, in terms of setting back from boundaries; and
- [minor projections](#) and projecting sections of wall which do not increase the basic impact of a wall may be accepted. For long runs of wall it is best to relieve the run by using indented sections, at greater [setback](#) distance from the boundary.

The height of the wall adjacent to that boundary (side and rear) should generally be lower the closer that wall is to the boundary. The height of a wall in relation to the setback from the boundary should be measured in terms of its overall impact on an adjoining property. In the case of a boundary wall where there is an existing abutting boundary wall, the proposed wall should match the alignment of the other boundary wall.

It should be noted that boundary fences are not matters controlled by the R-Codes Volume 1. However, boundary fences are used as a means to address visual privacy.

#### Exceptions to basic setback provisions

Consideration of [setbacks](#) should have regard to the [natural ground level](#), shape, development and orientation of adjoining [lots](#).

A reduction to the R-Codes Volume 1 [deemed-to-comply](#) setback requirements should only be considered where it can be demonstrated this is preferable for practical or aesthetic reasons, and will not be to the detriment of the amenity of adjoining properties, particularly where the reduced setback may result in increased overshadowing, overlooking or lack of privacy. In these situations the [building](#) design would need to address the [design principles](#) of [clause 5.1.3](#).

As illustrated in [figure 4f](#) of the R-Codes Volume 1, in the case of a [battleaxe lot](#) only, the stated setback distance may also be reduced by half the width of an adjoining [right-of-way](#), pedestrian access way or public open space reserve to a maximum of two metres.



## 4 Design elements of the R-Codes Volume 1 – Context

[Return to contents page](#)

### 4 Design elements of the R-Codes Volume 1 – Context

General

Specific design elements

4.1 Street setback

4.2 Lot boundary setbacks

4.3 Open space

4.4 Building height

4.5 Site area  
– Part 5 of R-Codes Volume 1

4.6 Communal open space – Part 5 of the R-Codes Volume 1

General guidelines

### 4.3 Open space

[\(Clause 5.1.4 of the R-Codes Volume 1\)](#)

In the R-Codes, [open space](#) means that part of a [site](#) not covered by buildings and available for the use of residents, including those areas at ground level, covered for weather protection or shade but not used as part of the dwelling. Above ground areas, external to [dwellings](#), readily accessible and sufficiently large to be usable, such as roof decks, may be included as part of the area allocated to open space. Note that roof decks, balconies and other outdoor living areas would be subject to visual privacy provisions of [clause 5.4.1](#) of the R-Codes Volume 1.

#### 4.3.1 Open Space – Part 5 of R-Codes Volume 1

[\(Clause 5.1.4 of the R-Codes Volume 1\)](#)

Open space serves several functions (figure 15):

- a setting for [buildings](#);
- access and car parking;
- leisure opportunities for a range of domestic activities: gardening; children's play; outdoor entertaining, and leisure as an extension of inside activities, the pursuit of hobbies; and
- space for functional purposes, such as clothes drying and storage of household items.

Open space is an important component of the character of a location. In suburban areas, greater open space is important to maintain the open, landscaped feel that is expected. In areas of higher density, lesser open space is warranted to support a more urbanised streetscape.

[Private open space](#) is synonymous with open space in the case of [single houses](#) and [grouped dwellings](#).

As the manner in which open space is used may vary over the life of the dwelling, and is more likely to be reduced than increased, it is important to retain flexibility and, accordingly, the R-Codes Volume 1 should not unduly constrain how open space is provided. Adequate open space should, however, be retained for the life cycle of the dwelling.

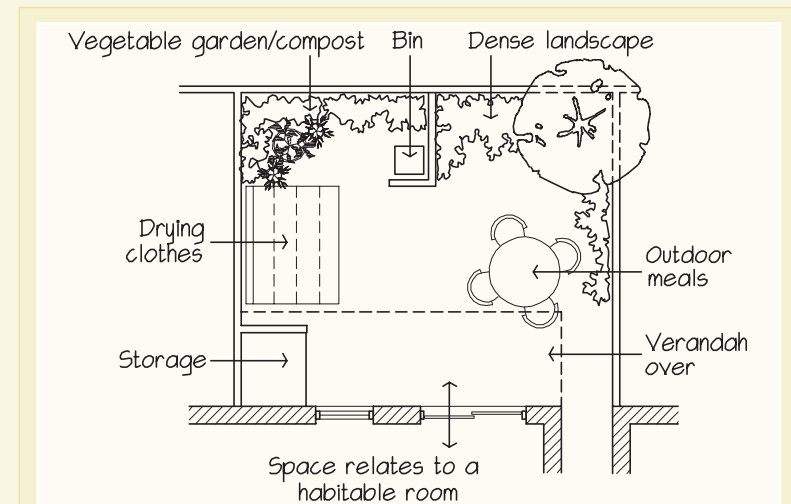

**Figure 15:** Open space provides many functions on a residential lot.



## 4 Design elements of the R-Codes Volume 1 – Context

[Return to contents page](#)

### 4 Design elements of the R-Codes Volume 1 – Context

General

Specific design elements

4.1 Street setback

4.2 Lot boundary setbacks

4.3 Open space

4.4 Building height

4.5 Site area  
– Part 5 of R-Codes Volume 1

4.6 Communal open space – Part 5 of the R-Codes Volume 1

General guidelines

### 4.4 Building height

[\(Clause 5.1.6 of the R-Codes Volume 1\)](#)

#### Measuring building height

[Figure series 7](#) of the R-Codes Volume 1 provide a standard method of height measurement designed to reduce ambiguity and confusion.

[Building height](#) is relatively straightforward to measure and administer as a control. There are two basic measures that can be used; one being height in storeys and the other height in metres. The former has problems of definition (for example, what constitutes a storey, use of roof spaces and mezzanines) and also can vary, depending on ceiling heights. For the purpose of the R-Codes Volume 1, the measure used is height in metres.

For administrative simplicity, limits are often taken from a single point usually the level at the centre point, or centroid, of the [site](#) or averaged over a site. However, this approach lacks precision and can lead to unintended outcomes. Therefore, the R-Codes Volume 1 refer to the height of the building as the distance between the point where the base of the [wall](#) meets the [natural ground level](#) and measured to the highest point of a wall or roof of a [building](#) vertically above that point (for measurement guidance refer to figure series 7 of R-Codes Volume 1). This preferred method distinguishes it also from the measurement of the height of walls for the purposes of [setbacks](#), where the height is measured from natural ground level at points on the boundary corresponding to the wall in question. In the first case, the concern is about the general impact on the locality. In the second case the concern is about the specific impact on the [adjoining property](#).

#### Determining natural ground level

While most [sites](#) have reasonably constant slopes (less than a 1–2m fall across a [lot](#)), there may be cases where the terrain is irregular, as follows:

- fractured, so as to vary significantly from one point to another; or
- convex, humped or containing an isolated high point or points; or
- concave, hollowed out at one or more places.

In these cases common sense and sound [design principles](#) dictate that the natural contours should be interpolated so as to modify or smooth out such anomalies for the purposes of establishing a common level for height calculation ([figure 7b](#) of the R-Codes Volume 1).

It has become common practice to provide level sites with boundary retaining walls at subdivision. In these cases, the levels so established at subdivision are deemed to be natural ground levels.

In accordance with the definitions:

- height shall be measured from the natural ground level immediately below the relevant point on the wall or roof;
- natural ground level may be taken as the levels resulting from [development](#) carried out as an approved part of a land subdivision; and
- [minor projections](#) such as chimneys, television aerials, satellite dishes and vent pipes are exempted.

#### Views

Obtaining and keeping views is a significant issue, particularly where a locality's housing values place a premium on an outlook or featured landscape views.

Because views are an important part of the amenity shared and enjoyed by many people in certain areas, a proponent should take into account the desirability of protecting those views enjoyed by neighbours, and the public to the extent that it is possible to design the [dwelling](#) to enjoy the view, but not to the exclusion or detriment of others.

While the R-Codes Volume 1 cannot guarantee the protection of views, the [decision-maker](#) may exercise a degree of control by [primary](#) and [secondary street](#) setbacks and height controls enhanced by [local planning policies](#) as permitted under [clause 7.3.1](#) of the R-Codes Volume 1. Alternatively the decision-maker may consider the development of local planning policies or [local development plans](#) which target the protection of views. This approach would identify views ahead of potential development and may require visual assessment and reliance on technical opinion rather than advertisement for public comment and objections to specific proposal(s).



## 4 Design elements of the R-Codes Volume 1 – Context

[Return to contents page](#)

### 4 Design elements of the R-Codes Volume 1 – Context

General

Specific design elements

4.1 Street setback

4.2 Lot boundary setbacks

4.3 Open space

4.4 Building height

4.5 Site area  
– Part 5 of R-Codes Volume 1

4.6 Communal open space – Part 5 of the R-Codes Volume 1

Part 5 only

### 4.4.1 Building height – Part 5 of R-Codes Volume 1

#### [\(Clause 5.1.6 of the R-Codes Volume 1\)](#)

The consumer/lifestyle trend towards double storey (and sometimes three storey) development raises issues of overshadowing, visual dominance and concern for privacy. The [building height](#) requirements of the R-Codes Volume 1 aim to address these matters (refer to figure 16).



**Figure 16:** Building heights in Part 5 of the R-Codes Volume 1 relate to one, two and three storey limits.

#### Common height limits

It is common for [decision-makers](#) to impose height limits on [residential development](#) in order to maintain consistency of streetscapes to minimise privacy conflicts and loss of views. However, there is a lack of consistency between decision-makers in terms of how [building height](#) is measured and the precise limits imposed. It is therefore desirable for the R-Codes Volume 1 to address height.

Regulation of building height and [setback](#) is fundamental to defining the streetscape, and in character areas or other places with special design sensitivity, the appropriate limits should be determined on a local streetscape basis, via [scheme](#) provisions, [local planning policies](#) or [local development plans](#).

The R-Codes Volume 1 establish an objective set of building height limits that correspond approximately to one, two and three-storey building heights. A default provision establishes Category B, corresponding to two storeys, as a limit in the absence of a local planning policy.

A decision-maker may adopt Category A or C for all or parts of its district as an amended requirement through the adoption of a local planning policy. A decision-maker may also adopt Category A or C for specific types of development, such as development upon rear battleaxe [sites](#), through local planning policies.

Building height of a proposal may be considered appropriate where:

- the building height of the proposed development is consistent with the building heights of existing and adjacent [buildings](#) in the locality; or
- meets objectives identified in [local planning policies](#) and/or [local development plans](#) adopted for the locality; and
- has little or no adverse impact on the amenity of [adjoining properties](#), including the public domain and natural areas.



## 4 Design elements of the R-Codes Volume 1 – Context

[Return to contents page](#)

### 4 Design elements of the R-Codes Volume 1 – Context

General

Specific design elements

4.1 Street setback

4.2 Lot boundary setbacks

4.3 Open space

4.4 Building height

4.5 Site area  
– Part 5 of R-Codes Volume 1

4.6 Communal open space – Part 5 of the R-Codes Volume 1

Part 5 only

### 4.5 Site area – Part 5 of R-Codes Volume 1

[\(Clause 5.1.1 of the R-Codes Volume 1\)](#)

#### Density control and R-Codes Volume 1

The R-Code number, or density code, provides a guide to the permissible maximum density of [development](#)

For example, in the case of a subdivided [lot](#) with a density code of R30, this would generally indicate a density of 30 dwelling units per hectare is possible. The density code applied to land is a maximum density, that is, landowners may elect to develop below the assigned density code, usually to create larger [dwellings](#) at the expense of the number of dwellings.

The density coding is, therefore, at best a rudimentary guide to neighbourhood or district density, in particular because it cannot be assumed that all types of dwellings may be built according to the standards of each density code. For instance [single houses](#) in areas exceeding R100 are subject to R80 standards.

#### Interpretation of average site area

The average [site areas](#) set out in column 3 of [table 1](#) within the R-Codes Volume 1 are used to determine the development potential of sites and ensure that the density of development is in line with the density code. It provides flexibility by allowing a range of lot sizes to be developed subject to the minimum site area being achieved.

#### Interpretation of minimum site area

The minimum site areas set out in column 3 of [table 1](#) are related to different housing types as follows:

Single houses: the area of a [green title](#), [strata lot](#) or [survey strata lot](#).

[Grouped dwellings](#): the area of a defined site for each [dwelling](#); it includes the area occupied by the dwelling itself, and other areas set aside for the exclusive use of that dwelling. It excludes any areas of [common property](#) (although these are included for the purposes of

calculating the average [site area](#)). This corresponds to the area defined in a strata lot or survey strata lot.

[Multiple dwellings](#): the total area of the [development site](#) divided by the number of dwellings.

#### Measuring the minimum site area

The area of a development site should be assessed on its minimum useable [site area](#), taking account of factors that may reduce, or increase, its capacity to provide for [residential development](#).

These factors include:

- the area of corner truncations, within limits, as these are normally indistinguishable from the [lot](#) itself, and can be visually part of the [site](#) ([figure 1a](#) of the R-Codes Volume 1);
- in the case of [battleaxe lots](#), the effective loss of area by virtue of additional confinement and the necessity of providing additional area for vehicle manoeuvring and access on site; and
- the corresponding benefits enjoyed by battleaxe lots that adjoin [rights-of-way](#), and which reduce both the confinement factor and the need for vehicle manoeuvring space ([figure 1b](#) of the R-Codes Volume 1).

#### Battleaxe sites

In terms of useable site area it is recognised that the difficulties associated with development of battleaxe [sites](#) increase as lots become smaller and the access-leg takes up a proportionally large part of the site. While it is reasonable to expect that higher density codes would provide less spaciousness and amenity, [battleaxe lot](#) subdivision especially on an ad hoc basis does not result in efficient use of residential land.

Accordingly the area requirement for battleaxe lots shown in [table 1](#) takes the minimum site area for the relevant R-Code and adds a constant multiple of the R-Code number. This assures that the reducing minimum site area is counterbalanced by the larger proportional area dedicated to the battleaxe requirement. The method of calculating the requirement for battleaxe lots and arriving at the figures shown on [table 1](#) is by adding to the minimum site area under the relevant R-Code number multiplied by five.





## 4 Design elements of the R-Codes Volume 1 – Context

[Return to contents page](#)

### 4 Design elements of the R-Codes Volume 1 – Context

General

Specific design elements

4.1 Street setback

4.2 Lot boundary setbacks

4.3 Open space

4.4 Building height

4.5 Site area  
– Part 5 of R-Codes Volume 1

4.6 Communal open space – Part 5 of the R-Codes Volume 1

Part 5 only

The additional requirement is sufficient to accommodate the access leg provided it constitutes no more than 20 per cent of the site area in column 4 of [table 1](#) and, therefore, the site area requirement is inclusive of the access leg ([figure 1b](#) of the R-Codes Volume 1).

The maximum area of the access leg component is as follows: R10 (185m<sup>2</sup>); R12.5 (152.5m<sup>2</sup>); R15 (131m<sup>2</sup>); R17.5 (117.5m<sup>2</sup>); R20 (90m<sup>2</sup>); R25 (85m<sup>2</sup>); R30 (82m<sup>2</sup>); R35 (79m<sup>2</sup>) and R40 and above (76m<sup>2</sup>). Where the boundary of a battleaxe lot, excluding the battleaxe leg adjoins or abuts a [right of way](#) or public reserve for open space, pedestrian access, school site or equivalent, half of the width of the right-of-way (up to a maximum depth of 2m) or the reserve up to a depth of 2m may be added to the site area ([figure 1b](#) of the R-Codes Volume 1).

#### Variations to minimum and average site area requirements

The minimum and average [site areas](#) for [single houses](#) and [grouped dwellings](#) stipulated in [table 1](#) may not be varied, except where an application for subdivision approval is made to the [WAPC](#) and the application satisfies certain criteria, [clause 5.1.1 P1.2](#) of the R-Codes Volume 1, provides for a maximum lot size variation of 5 per cent to be considered. This provides some flexibility to accommodate minor reductions to minimum and average site areas while providing a maximum of 5 per cent to make clear that flexibility is limited. The subdivision of land is also subject to other WAPC policies, particularly [Development Control Policy 2.2 Residential Subdivision](#).

#### Undersized lots, survey strata lots and strata lots

Previous subdivision of an area may have resulted in [lots](#), [survey strata lots](#) and [strata lots](#) which are smaller than the minimum prescribed under a particular R-Code. [Clause 5.1.1 C1.4iii](#) recognises that despite this anomaly, the R-Codes Volume 1 should not restrict development of such properties for single houses, grouped dwellings or [multiple dwellings](#).

In addition, provisions are included ([clause 5.1.1 P1.3](#) of the R-Codes Volume 1) to allow for the consideration of survey strata lot or strata lot subdivision of existing authorised grouped dwelling and multiple dwelling [developments](#) that were constructed prior to the introduction of the R-Codes Volume 1, despite the fact that the resulting [lots](#) may contain a lesser area than that specified in [table 1](#) of the R-Codes Volume 1.

#### Site area variations for special purpose dwellings

A density variation or concession for an [aged](#) or [dependent persons' dwelling](#) and [single bedroom dwellings](#) is incorporated under [clause 5.1.1 C1.4i](#) of the R-Codes Volume 1. The concession is calculated by reducing the minimum and/or average [site area](#) requirements by one-third and calculating the number of aged or dependent persons' dwellings or single bedroom dwellings accordingly. For example, under the R20 Code, each dwelling requires a site area of 450m<sup>2</sup>. Application of the density concession may reduce this down to 300m<sup>2</sup>. In the case of a 1,200m<sup>2</sup> [site](#), under this R-Code designation could potentially allow four aged or dependent persons' dwellings or single bedroom dwelling units.

The density concession does not mean that the coding of a lot is amended, with consequences for other requirements. For example, application of the density concession to a [lot](#) with an R-Code of R20 does not mean that the coding is increased to R30, or that the [street setback](#) or [open space](#) requirements of the R20 code are replaced by those of R40.

#### Land title implications

The subdivision of land to create [green title](#) lots, strata lots or survey strata lots for single houses and grouped dwellings requires the approval of the WAPC; although, a proposed built strata plan that does not create more than five lots and contains existing dwellings, only requires local approval. [Figure 23](#) illustrates different housing arrangements on different titles.

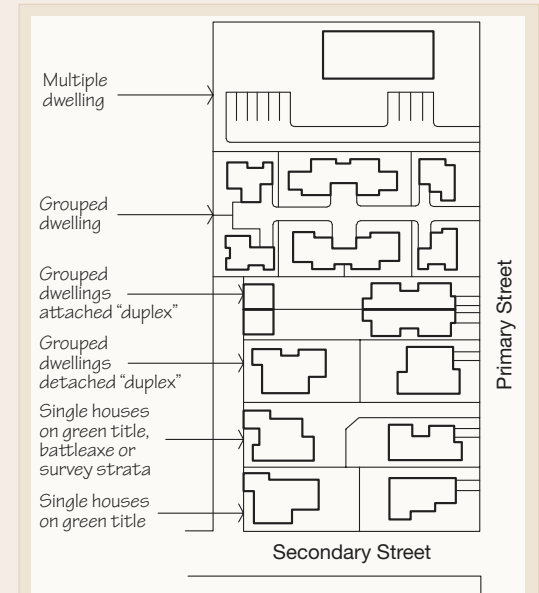

**Figure 23:** Housing arrangements on different titles.



## 4 Design elements of the R-Codes Volume 1 – Context

[Return to contents page](#)

### 4 Design elements of the R-Codes Volume 1 – Context

General

Specific design elements

4.1 Street setback

4.2 Lot boundary setbacks

4.3 Open space

4.4 Building height

4.5 Site area  
– Part 5 of R-Codes Volume 1

4.6 Communal open space – Part 5 of the R-Codes Volume 1

Part 5 only

There are several implications as to the use of the R-Codes Volume 1 in the subdivision process:

- The minimum site area requirements under 5.1.1 of the R-Codes Volume 1 are intended to be guidelines for the WAPC in considering subdivision applications.
- The R-Codes Volume 1, as a consequence, include a provision which permits the approval of [development](#) on any green title lot, strata lot or survey strata lot previously approved by the WAPC even when the lot does not meet the minimum site area or [frontage](#) set out in the R-Codes Volume 1.
- A [dwelling](#) on a [survey strata lot](#) in a [survey strata plan](#) in which there is no [common property](#), or on a [strata lot](#) in a [strata plan](#) in which there is no common property is treated as a [single house](#) under the R-Codes Volume 1.

As with a green title lot, a survey strata lot or strata lot may be capable of development of more than one dwelling, given sufficient area.

In the past the R-Codes Volume 1 were applied to the entire [grouped dwelling](#) development and *then* the strata or survey strata lots were created. Subsequent redevelopment on individual or various housing units raised problems, many to do with how the R-Codes Volume 1 should be interpreted.

Development of each grouped dwelling must individually comply with the R-Codes Volume 1 in relation to area, [setbacks](#), car parking and other factors.

Grouped dwellings are set aside as individual [lots](#) and common areas under a strata or survey strata lot subdivision.

Should a developer or owner wish to subdivide a grouped dwelling development, such subdivision may be undertaken as either a strata or survey-strata lot subdivision under the *Strata Titles Act 1985* (as amended).

Requirements under the *Strata Titles Act 1985* for obtaining consent of a strata company to develop on a strata lot or survey strata lot are not affected by the R-Codes Volume 1 and are in addition to any requirement for consultation of the owners under the R-Codes Volume 1.

### 4.6 Communal open space – Part 5 of R-Codes Volume 1 ([Clause 5.1.5 of the R-Codes Volume 1](#))

[Table 1](#) does not require mandatory provision of [communal open space](#), however, it should be encouraged if considered appropriate within a [development](#). Communal open space is open space provided for the exclusive use of a defined group of residents. It serves a similar range of functions to that of [private open spaces](#) and includes:

- a setting for [buildings](#);
- space for active and passive recreation;
- other group activities, which may be very particular to a particular group of residents; and
- access to direct sun and natural ventilation.

Where communal open space is provided as part of a grouped dwelling development, some trade-off between private and communal open space should be allowed but not at the expense of the core provision of private open space.



## 5 Design elements of the R-Codes Volume 1 – Streetscape

[Return to contents page](#)

### 5 Design elements of the R-Codes Volume 1 – Streetscape

General

Specific design elements

5.1 Street surveillance

5.2 Street walls and fences

5.3 Sight lines

5.4 Setback of garages and carports  
– Part 5 of R-Codes Volume 1

5.5 Garage width  
– Part 5 of R-Codes Volume 1

5.6 Appearance of retained dwelling  
– Part 5 of R-Codes Volume 1

### General

#### [\(Clause 5.2 of R-Codes Volume 1\)](#)

The streetscape contributes to local character. Streetscapes are created by the relationship between landscape and built form, often separating public from private domains. High quality design should be consistent with the existing streetscape character. In order to enhance streetscape, [buildings](#) should address the [street](#) and create a strong connection and relationship to the street.

Irrespective of the suburban or urban context of an area, there are a number of elements of streetscapes that have general impacts on amenity. Broadly, apart from the character of an area, residents expect to maintain views and vistas, have security and passive surveillance, landscape and shade, safety of access, privacy and open space, and an attractive setting.

### Specific design elements

#### [\(Clause 5.2 of R-Codes Volume 1\)](#)

This design element deals with those factors that affect and contribute to the broader amenity of the streetscape. The following are provisions of part 5 of the R-Codes Volume 1:

- 5.1 street surveillance;
- 5.2 street walls and fences; and
- 5.3 sight lines.
- 5.4 setback of garages and carports;
- 5.5 garage width; and
- 5.6 appearance of retained dwelling.

Any other factors affecting streetscape are dealt with in other elements of the R-Codes Volume 1.



[Return to contents page](#)

### 5 Design elements of the R-Codes Volume 1 – Streetscape

General

Specific design elements

- 5.1 Street surveillance
- 5.2 Street walls and fences
- 5.3 Sight lines
- 5.4 Setback of garages and carports – Part 5 of R-Codes Volume 1
- 5.5 Garage width – Part 5 of R-Codes Volume 1
- 5.6 Appearance of retained dwelling – Part 5 of R-Codes Volume 1

#### General guidelines

### 5.1 Street surveillance

[\(Clause 5.2.3 of R-Codes Volume 1\)](#)

#### Interface between buildings and streetscape – designed with consideration of public safety and passive surveillance

Given the importance of crime prevention through environmental [design principles](#) it is appropriate to design [buildings](#), front fences and [walls](#) to ensure that a clear view exists between the building, particularly its main entry and the [street](#). This not only provides opportunity for incidental street surveillance but also contributes to streetscape amenity.

#### Casual surveillance and sightlines

Casual surveillance involves the location and design of facilities to maximise visibility of the [site](#). Maximising casual surveillance increases a sense of safety and can deter criminal activity. Clear sight lines, or the ability to see what is ahead along a route, or in a space, provide opportunities for casual surveillance. A clear sight distance provides an individual with both a perception of safety and adequate space to react to possible threats. Further information is provided in the [WAPC's Designing Out Crime Planning Guidelines](#).

#### Entries to buildings are legible from the street

Entries that are clearly defined from the street provide a distinction between private and public areas. Minimising the number of [dwellings](#) that share a common entrance along the [frontage](#) can spread the activity along the street. Providing individual pedestrian access points off the street to ground level dwellings can also assist in providing activity and surveillance. Pedestrian access should be appropriately designed to provide clear and secure access to the dwellings and should be the main focus of access to the site in preference to vehicle access.

#### Orientate development to maximise street frontage for balconies, living areas and common areas

Buildings with [street frontages](#) that employ [balconies](#), living areas and common areas contribute to increased casual surveillance of the street. This increases both actual and perceived levels of safety for pedestrians. The treatment of [building](#) frontages will reduce opportunities for concealment and entrapment, through safety by design.

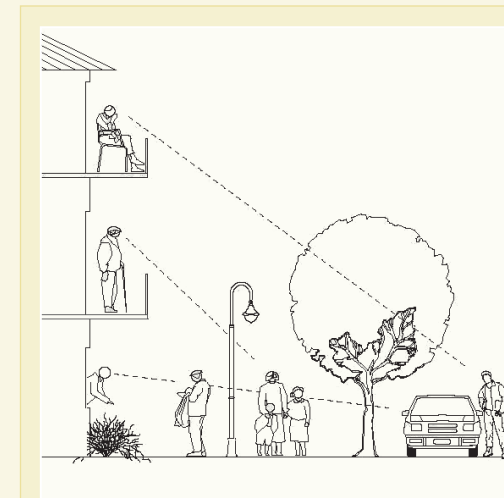

**Figure 31:** An example of effective sight lines and surveillance.



## 5 Design elements of the R-Codes Volume 1 – Streetscape

[Return to contents page](#)

### 5 Design elements of the R-Codes Volume 1 – Streetscape

General

Specific design elements

5.1 Street surveillance

5.2 Street walls and fences

5.3 Sight lines

5.4 Setback of garages and carports – Part 5 of R-Codes Volume 1

5.5 Garage width – Part 5 of R-Codes Volume 1

5.6 Appearance of retained dwelling – Part 5 of R-Codes Volume 1

General guidelines

### 5.2 Street walls and fences

[\(Clause 5.2.4 of R-Codes Volume 1\)](#)

#### Height of street walls and fences

In recent times and with the trend for larger houses and smaller [lots](#), there is a tendency for some owners to construct high [walls](#) or fences at or near the [street](#). This is often justified by the proponent for reasons of privacy, security or protection from traffic noise or headlights.

High walls and solid fences on the front boundary are undesirable because they visually affect the streetscape and generally separate residents from their street and what occurs in it (refer to figure 35).

#### Provide a clear distinction between private and public areas

[Buildings](#) that facilitate a visual connection between the street and private spaces can provide opportunities for high levels of casual surveillance of the street. Appropriate treatment of [street walls](#) and fences can clearly define the boundary between private and public areas and contribute to an enhanced streetscape. This reinforces a visual connection between street users and private spaces.

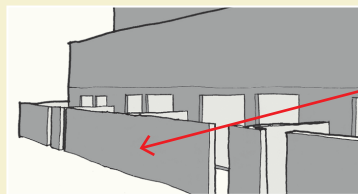

Fencing is non-permeable and prevents visual connection between private and public property.

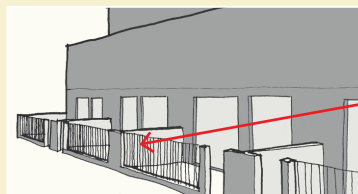

Fencing is permeable and allows visual connection with the street while providing security and delineating private and public property.

**Figure 35:** Fencing should not impede visual surveillance of the street by either being too high and/or non-permeable.

Part 5 only

### 5.2.1 Street walls and fences – Part 5 of R-Codes Volume 1

[\(Clause 5.2.4 of R-Codes Volume 1\)](#)

Fences higher than 1.2m should be [visually permeable](#) along all [street](#) types, including [communal streets](#). Where a [dwelling](#) fronts onto an arterial road carrying high traffic volumes, or where protection is needed from headlight glare from such a road, there may be a case to justify a high [wall](#) especially to provide privacy to an [outdoor living area](#). In these circumstances a solid wall of up to 1.8m high would be acceptable for a minimal proportion of the [frontage](#), on approval by the [decision-maker](#) and provided the remainder of the frontage provides for views to the street. [Design principles](#) are provided in the R-Codes Volume 1 to guide circumstances where a decision-maker could grant such approval.

Ideally, outdoor living areas should be located behind the [setback](#) line (R-Codes Volume 1 [clause 5.3.1](#)), however, in some circumstances the only possible location for an outdoor living area will be in the street setback area. Where a narrow [lot](#) faces north to the street, the street setback area may be the only possible area open to winter sun. In these cases, part of the area should be permitted to be screened from view for privacy. Where a private courtyard is unavoidable in the front setback area, [screening](#) with dense planting and/or a permeable fence that will provide reasonable privacy is appropriate (refer to figures 36 - 38).



**Figure 36:** Traditional and low fences are acceptable.



**Figure 37:** High walls are not acceptable unless in exceptional circumstances.



## 5 Design elements of the R-Codes Volume 1 – Streetscape

[Return to contents page](#)

### 5 Design elements of the R-Codes Volume 1 – Streetscape

General

Specific design elements

- 5.1 Street surveillance
- 5.2 Street walls and fences
- 5.3 Sight lines
- 5.4 Setback of garages and carports
  - Part 5 of R-Codes Volume 1
- 5.5 Garage width
  - Part 5 of R-Codes Volume 1
- 5.6 Appearance of retained dwelling
  - Part 5 of R-Codes Volume 1

Part 5 only



**Figure 38:** High street walls should be limited to the minimum necessary and be visually permeable.

General guidelines

### 5.3 Sight lines

[\(Clause 5.2.5 of R-Codes Volume 1\)](#)

[Driveways](#) need to maintain adequate sightlines where they intersect [streets](#), rights-of-way, and footpaths to ensure visibility and safety. Also, the corner of [lots](#) located at intersecting streets should maintain adequate sight lines. [Walls](#) are to be reduced in height to 0.75m within a 1.5m truncation to meet the [deemed-to-comply](#) provision. This is illustrated in [figure 9a](#) of the R-Codes R-Codes Volume 1 (refer to figure 41).

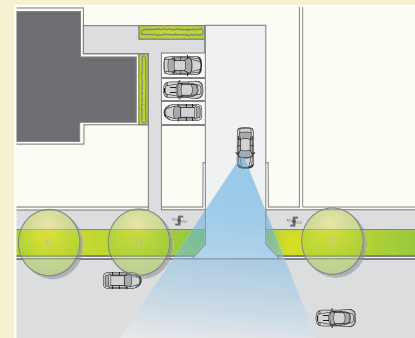

*Inadequate truncations are provided resulting in poor sight lines.*

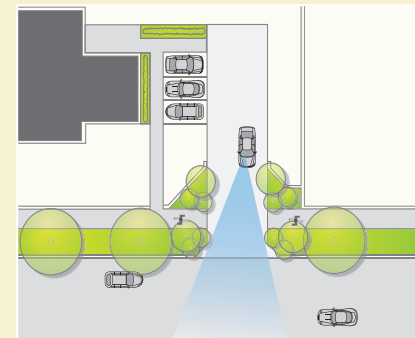

*Adequate truncations area provided, however, the landscaping has not been designed to facilitate clear views to the street.*

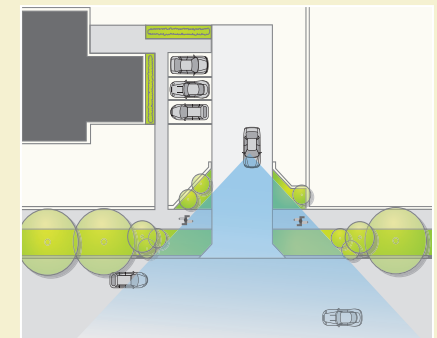

*Truncations are provided to the street in a manner that enables a safe view of the pedestrian and vehicular traffic before leaving the property boundary.*

**Figure 41:** Walls and fences should be truncated where the crossover meets the property boundary to ensure that vehicles can account for on-coming pedestrians and vehicles at the conflict point.



## 5 Design elements of the R-Codes Volume 1 – Streetscape

[Return to contents page](#)

### 5 Design elements of the R-Codes Volume 1 – Streetscape

General

Specific design elements

5.1 Street surveillance

5.2 Street walls and fences

5.3 Sight lines

5.4 Setback of garages and carports  
– Part 5 of R-Codes Volume 1

5.5 Garage width  
– Part 5 of R-Codes Volume 1

5.6 Appearance of retained dwelling  
– Part 5 of R-Codes Volume 1

Part 5 only

### 5.4 Setback of garages and carports – Part 5 of R-Codes Volume 1

[\(Clause 5.2.1 of R-Codes Volume 1\)](#)

For the purposes of the R-Codes Volume 1, a [carport](#) means an [unenclosed](#) roofed structure designed to accommodate a motor vehicle. Carports are entirely open at the front, sides and rear, except where one side is physically attached to a [dwelling](#) or built-up to a side boundary. A carport may incorporate doors to provide security for vehicles. However, the door must be designed and constructed so as to allow for clear and unobstructed views through to the dwelling, such as open grille doors or wrought iron type gates. All other structures for housing vehicles, including open-sided carports with solid doors, are deemed to be [garages](#).

Because many houses in established suburbs were built without provision for vehicles, street-side parking and parking in [street setback areas](#) have become essential, especially where rear access to the property is not available. With increasing affluence, car ownership rates have increased, as has the desire to provide a roof over vehicles.

Consequently it is accepted that, where no feasible alternative exists, the street setback area may be used for carports and unroofed parking spaces. Carports are acceptable, because they allow a clear view between a public street and a private dwelling. Garages are not acceptable except as provided by [clause 5.2.1 C 1.1](#), unless they can be accommodated without obstruction to views between [street](#) and house at ground level. Such exceptions are likely to be rare.

It is desirable for carports in an existing [setback](#) area to be set back sufficiently clear of any window of the dwelling so as not to unduly obstruct light to that window. Car parking spaces should not intrude into traditional [verandahs](#). In the case of complete redevelopment of a [site](#) in an established streetscape, any garage or carport accessed from the street should be set back in accordance with the general [building](#) setback unless:

- the area, dimensions or shape of the site make this unfeasible; or
- there is an established, consistent, pattern of carports within the setback area.

### 5.5 Garage width – Specific to Part 5 of R-Codes Volume 1

[\(Clause 5.2.2 of R-Codes Volume 1\)](#)

Garages are potentially dominant and often imposing elements on dwelling appearance and streetscapes, especially the now common double garages which occupy a large frontage of increasingly narrow width [lots](#).

The R-Codes Volume 1 limit the proportion of [frontage](#) and building façade that may be occupied by a garage ([figure 8c](#) of the R-Codes Volume 1). Assessment will need to weigh up the safe and convenient access to garages while maintaining a streetscape not dominated by garage doors. [Decision-makers](#) may encourage the integration of garages into the design of the dwelling by considering changes to setback provisions when assessing proposals that address [design principles](#) relating to streetscape refer to figure 42).



**Figure 42:** Garage doors, particularly on narrow lots, can be an imposing element in the streetscape.



[Return to contents page](#)

### 5 Design elements of the R-Codes Volume 1 – Streetscape

General

Specific design elements

- 5.1 Street surveillance
- 5.2 Street walls and fences
- 5.3 Sight lines
- 5.4 Setback of garages and carports
  - Part 5 of R-Codes Volume 1
- 5.5 Garage width
  - Part 5 of R-Codes Volume 1
- 5.6 Appearance of retained dwelling
  - Part 5 of R-Codes Volume 1

Part 5 only

### 5.6 Appearance of retained dwelling – Part 5 of R-Codes Volume 1

[\(Clause 5.2.6 of R-Codes Volume 1\)](#)

Under [deemed-to-comply clause 5.2.6 C6](#), where an existing dwelling is to be retained as part of a [grouped dwelling development](#), the appearance of the retained dwelling is to be upgraded externally to an acceptable maintenance standard as the rest of the development.

Ordinarily this would be required as a condition of planning approval to the development. [Decision-makers](#) may prepare a [local planning policy](#) to provide guidance on acceptable maintenance standards.

This provision would not apply if the development would result in the subsequent subdivision of the existing dwelling as a [single house](#) (either [green title](#), strata or [survey strata](#) without [common property](#)).

There is no ability to require upgrading of the existing [\(grouped\) dwelling](#) once the [lot](#) title of the property containing the existing dwelling has been separated from that of the [development site](#).





## 6 Design elements of the R-Codes Volume 1 – Site planning and design

[Return to contents page](#)

### 6 Design elements of the R-Codes Volume 1 – Site planning and design

General

Specific design elements

6.1 Outdoor living areas

6.2 Landscaping

6.3 Parking

6.4 Design of car parking spaces

6.5 Vehicular access

6.6 Site works

6.7 Retaining walls

6.8 Stormwater management

6.9 Pedestrian access – Part 5 of R-Codes Volume 1

### General

#### [\(Clause 5.3 of R-Codes Volume 1\)](#)

The [development site](#) needs to accommodate all the functionality requirements to ensure that the amenity for residents is maximised by the provision of high quality facilities that are well located and accessible, while minimising impact of the [development](#) on adjoining land users.

[Outdoor living areas](#) provide outdoor amenity for users of [dwellings](#). The [landscape](#) treatment of open spaces such as those within [street setback areas](#) is important in creating consistent and attractive [communal](#) streetscapes.

Natural topographical features of the land contribute significantly to local character. Development should aim to respect the natural topography of the area by minimising cut and fill of land. Significant fill is discouraged, as privacy and overshadowing issues often result.

It is important for a [site](#) to effectively deliver facilities and areas for use by residents, such as outdoor living areas, landscaping, parking, and access.

### Specific design elements

#### [\(Clause 5.3 of R-Codes Volume 1\)](#)

This design element deals with matters that affect the physical planning and design of development. Provisions that relate to Part 5 of the R-Codes Volume 1 include:

- 6.1 Outdoor living areas;
- 6.2 Landscaping;
- 6.3 Parking;
- 6.4 Design of car parking spaces;
- 6.5 Vehicular access;
- 6.6 Site works;
- 6.7 Retaining walls; and
- 6.8 Stormwater management.
- 6.9 Pedestrian access.



[Return to contents page](#)

### 6 Design elements of the R-Codes Volume 1 – Site planning and design

General

Specific design elements

6.1 Outdoor living areas

6.2 Landscaping

6.3 Parking

6.4 Design of car parking spaces

6.5 Vehicular access

6.6 Site works

6.7 Retaining walls

6.8 Stormwater management

6.9 Pedestrian access – Part 5 of R-Codes Volume 1

#### General guidelines

### 6.1 Outdoor living areas

[\(Clause 5.3.1 of R-Codes Volume 1\)](#)

At least one outdoor area for each [dwelling](#) is required for entertaining and leisure that is:

- large enough to be functional and usable;
- easily accessible from a [habitable room](#); and
- with access, if possible, to winter sun.

Outdoor living areas should be oriented to make best use of northern sunlight, (where climatically appropriate) and provide opportunities for natural ventilation by cooling breezes.

#### Part 5 only

### 6.1.1 Outdoor living areas – Part 5 of R-Codes Volume 1

[\(Clause 5.3.1 of R-Codes Volume 1\)](#)

Because of the importance of providing shade in summer, especially in conjunction with outdoor living areas, a part of the [outdoor living area](#) (up to one-third) can be roofed. This is also to ensure access to natural light into the outdoor area is maintained.



[Return to contents page](#)

### 6 Design elements of the R-Codes Volume 1 – Site planning and design

General

Specific design elements

6.1 Outdoor living areas

6.2 Landscaping

6.3 Parking

6.4 Design of car parking spaces

6.5 Vehicular access

6.6 Site works

6.7 Retaining walls

6.8 Stormwater management

6.9 Pedestrian access – Part 5 of R-Codes Volume 1

### General guidelines

## 6.2 Landscaping

### (Clause 5.3.2 of R-Codes Volume 1)

The [landscaping](#) of [street setback areas](#), both public and communal, makes an important contribution to the streetscape. Landscaping is even more important in the case of [grouped](#) and [multiple dwelling developments](#), because of the intensity of development and land use, and because the development makes such a large contribution to the overall streetscape (refer to figure 49).

Landscaping should be designed and installed with regard for the following aspects:

- the desirability of creating attractive streetscapes;
- meets the projected needs of the residents;
- enhances security and safety for residents;
- provides new trees and vegetation for shade and to complement [building](#) form;
- the desirability of protecting existing trees where possible;
- the considered design and choice of materials for surfaces, such as vehicle access ways and crossovers, parking areas and [outdoor living areas](#);
- solar access throughout the year that will influence the choice of trees and plants and their placement; and
- the need for shade structures, such as [pergolas](#), to complement trees and enhance microclimate.



*Landscaping enhances outlook from apartments as well as facilitating stormwater infiltration.*

**Figure 49:** Landscaping provided to complement the appearance and function of the building.

### Maximise areas for natural planting by only hard-surfacing areas of necessity

Minimise the area of hard surfaces to provide sufficient areas for trees to grow which also maximises the amount of water penetration to the soil. Refer also section 6.8 of guidelines regarding [clause 5.3.9](#) of the R-Codes Volume 1 – stormwater management.

### Provide planting types in appropriate locations that allow for solar access in the winter and shading in the summer

The [landscaping](#) on a [site](#) can impact solar access to [habitable rooms](#) and private [outdoor living areas](#). The selection of vegetation and planting locations should also ensure that solar access of both residents and neighbouring properties will not be adversely affected in the future once the vegetation matures.



[Return to contents page](#)

### 6 Design elements of the R-Codes Volume 1 – Site planning and design

General

Specific design elements

6.1 Outdoor living areas

6.2 Landscaping

6.3 Parking

6.4 Design of car parking spaces

6.5 Vehicular access

6.6 Site works

6.7 Retaining walls

6.8 Stormwater management

6.9 Pedestrian access – Part 5 of R-Codes Volume 1

#### General guidelines

### Plan landscaping to avoid obstructing pedestrian and vehicle sight lines

[Landscaping](#) can be used to define entry points and specific [building](#) elements. It is important, however, to consider the impact of the landscaping on sight lines, ensuring that they do not compromise the casual surveillance across the site, or obscure sight lines at pedestrian and vehicle crossings (refer to figure 50).



*Dense landscaping provided between the building and the street, however, visual surveillance is maintained.*

*The landscaping is a key feature in defining the building.*

**Figure 50:** Landscaping provided to maintain visual surveillance and define the building.

### Design landscaping along the streetscape to reflect the existing or future desired character of the area

Where there is a streetscape character defined by landscaping, such as continuous [street](#) tree plantings or hedges, design the landscaping to be consistent with that established streetscape character.

### Private open space

[Private open space](#) is developed to suit the requirements of occupants and is likely to be modified over time as occupiers' requirements and landscaping trends change.

Consequently, the R-Codes Volume 1 require the provision of landscaping as part of the development of [communal open space](#), and where required, [common property](#), but not of [private open space](#).

### Communal open space

Although [grouped](#) and [multiple dwellings](#) (under part 5 of the R-Codes Volume 1) are not required to provide [communal open space](#), it should not be discouraged if considered appropriate within a [development](#). Communal open space is open space provided for the exclusive use of a defined group of residents (refer also to section 4.6, of guidelines and [clause 5.1.5](#) of the R-Codes Volume 1). It serves a similar range of functions to that of private open spaces that include:

- a setting for buildings
- space for active and passive recreation
- other group activities
- access to direct sun.



[Return to contents page](#)

### 6 Design elements of the R-Codes Volume 1 – Site planning and design

General

Specific design elements

6.1 Outdoor living areas

6.2 Landscaping

6.3 Parking

6.4 Design of car parking spaces

6.5 Vehicular access

6.6 Site works

6.7 Retaining walls

6.8 Stormwater management

6.9 Pedestrian access – Part 5 of R-Codes Volume 1

### General guidelines

## 6.3 Parking

[\(Clause 5.3.3 of R-Codes Volume 1\)](#)

### Provision of car parking

The R-Codes Volume 1 adopt the basic position of requiring adequate on-site provision of parking to the assessed need. The [decision-maker](#) can exercise technical judgement where appropriate and is justified to relax on-site parking requirements when:

- the applicant can demonstrate that actual demand is lower; or
- satisfactory alternate parking provision is available and accessible in close proximity other than on-site.

There is a long accepted principle that the demand for car parking generated by a [residential development](#) should be accommodated on the [development site](#). The main exceptions to this are:

- In most cases visitors' car parking for [single houses](#) (that is, low density development) can be accommodated in the [driveway](#) or [street](#) (via on-street/verge parking where permitted).
- In many older areas, pre-dating widespread ownership and reliance on private cars, off-street car parking provision is not feasible without a detrimental change to character housing and the streetscape, especially as these areas tend to be developed with small [street setbacks](#) and narrow [lots](#) and often where no on-street/verge parking is permitted.

The need for on-site provision for car parking relates to the availability of parking on the street. Where a street has exceptionally wide verges which can be used for parking, the actual need for on-site parking may be quite small, although some owners who wish to secure their vehicle would still prefer on-site parking to be provided.

### Calculating car parking requirement

Where [deemed-to-comply](#) provisions for on-site parking require a fraction of a space, it must be rounded up to the nearest higher whole number.

### Tandem car bays

In the case of [single houses](#), [grouped](#) and [multiple dwellings](#), two cars bays in tandem would be considered two bays where they relate specifically to one [dwelling](#).

### Reduced car parking requirements

[Clause 5.3.3](#) of the R-Codes Volume 1 detail that smaller dwellings (either by size or number of bedrooms) may have reduced car parking requirements. This is based on the premise that smaller dwellings tend to have less demand for car parking, as the anticipated inhabitants per dwelling is lower. In addition, a further reduction is provided for when the dwelling is located in close proximity to convenient public transport.

### Measuring distance to train stations and bus routes

In inner urban and suburban areas with good access to public transport, shops and other facilities, the demand for car parking may be less than in areas less well served with public transport, shops and other facilities.

The car parking requirements set out in [clause 5.3.3](#) of the R-Codes Volume 1 provide for reduced on-site parking where a site is located within 800m of a train station or within 250m of a [high frequency bus route](#).

A [development](#) proposal is eligible for assessment under column A of [clause 5.3.3 C3.1](#) of the R-Codes Volume 1 if any part of the subject [lot](#) is within:

- 800m to a train station located on a [high frequency rail route](#), measured in a straight line from the pedestrian entry to the train station platform to any part of the subject lot; or
- 250m from a high frequency bus route, measured in a straight line from any location along the route to any part of the subject lot.

High frequency rail/bus routes are defined as public transport routes with timed stops that run a service at least every 15 minutes during weekday peak periods (7 to 9am and 5 to 7pm).



## 6 Design elements of the R-Codes Volume 1 – Site planning and design

[Return to contents page](#)

### 6 Design elements of the R-Codes Volume 1 – Site planning and design

General

Specific design elements

6.1 Outdoor living areas

6.2 Landscaping

6.3 Parking

6.4 Design of car parking spaces

6.5 Vehicular access

6.6 Site works

6.7 Retaining walls

6.8 Stormwater management

6.9 Pedestrian access – Part 5 of R-Codes Volume 1

#### General guidelines

### On-street car parking

On-street car parking should be limited in circumstances where:

- there is heavy traffic in the [street](#) and kerbside parking may be unsafe, or even prohibited, at least during peak hours;
- [frontages](#) are narrow and crossovers frequent, limiting the length of kerb available for parking;
- the street is too narrow; and/or
- space for kerbside parking is taken up by other uses or activities.

### Where parking capacity is available on-street or in other off-street parking, on-site parking requirements can be reduced

On-street parking is a valuable community resource that serves a variety of social and economic needs including residential uses. [Decision-makers](#) need to consider how to achieve a balance between different uses in areas with high and/or competing needs. While no one particular use should be favoured, satisfaction of some of the demand for residential parking, especially visitor and service/delivery parking, is a reasonable use for on-street parking.

In locations where there are existing parking facilities with capacity, arrangements can be made to provide parking off-site through contract. Where it is determined through a traffic management study that there is capacity in the on-street parking system, on-site parking requirements can be reduced.

#### Part 5 only

### 6.3.1 Parking – Part 5 of R-Codes Volume 1

[\(Clause 5.3.3 of R-Codes Volume 1\)](#)

#### Visitor parking provision for grouped and multiple dwellings

[Clause 5.3.3 C3.2](#) of the R-Codes Volume 1 includes a requirement for the provision for visitor parking for [grouped](#) and [multiple dwelling developments](#) that share common access, which is expressed as:

*On-site visitors car parking spaces for grouped and **multiple dwelling developments** provided at a rate of one space for each four **dwellings**, or part thereof in excess of four **dwellings**, served by a common access.*

This means there is no requirement for visitor parking until the number of [dwellings](#) exceeds four, and then one visitor bay is required to be provided for every additional four dwellings served by a common access (that is, 0-4 dwellings with common access = nil visitor bays; 5-8 dwellings with common access = 1 visitor bay; 9-12 dwellings with common access = 2 visitor bays; 13-16 dwellings with common access = 3 visitor bays and so on).



## 6 Design elements of the R-Codes Volume 1 – Site planning and design

[Return to contents page](#)

### 6 Design elements of the R-Codes Volume 1 – Site planning and design

General

Specific design elements

6.1 Outdoor living areas

6.2 Landscaping

6.3 Parking

6.4 Design of car parking spaces

6.5 Vehicular access

6.6 Site works

6.7 Retaining walls

6.8 Stormwater management

6.9 Pedestrian access – Part 5 of R-Codes Volume 1

General guidelines

### 6.4 Design of car parking spaces

[\(Clause 5.3.4 of R-Codes Volume 1\)](#)

The design of parking and manoeuvring spaces is set out in AS/NZS 2890.1:2004, Parking facilities: Off-street car parking and AS 2890.1:1993, Parking facilities: Off-street car parking. The R-Codes Volume 1 reference these standards in as much as they relate to residential properties.

Parking areas should be designed and located to minimise impacts on the residents of the [building](#) as well as adjoining properties. The location and design should have consideration for the impact of light (from both the headlights of vehicles as well as the fixed lighting of any parking areas), noise, odour and stormwater run-off. For external car parking areas and manoeuvring areas, acoustic screen fencing is effective in controlling the transmission of sound to adjoining properties (refer to figure 51).

#### Visitor parking

Visitor parking spaces required by clause [5.3.3 C3.2](#) of the R-Codes Volume 1 (section 6.3 of guidelines) shall be provided in a location that is accessible at all times, in addition to the [dwelling](#) parking requirement. Visitor parking should be clearly identified as visitors' parking bays and located in a location allowing unimpeded access.

Visitor parking spaces should not be located within a secured private or common parking [garage](#) that requires a key, handset or other electrical or mechanical device to gain access.

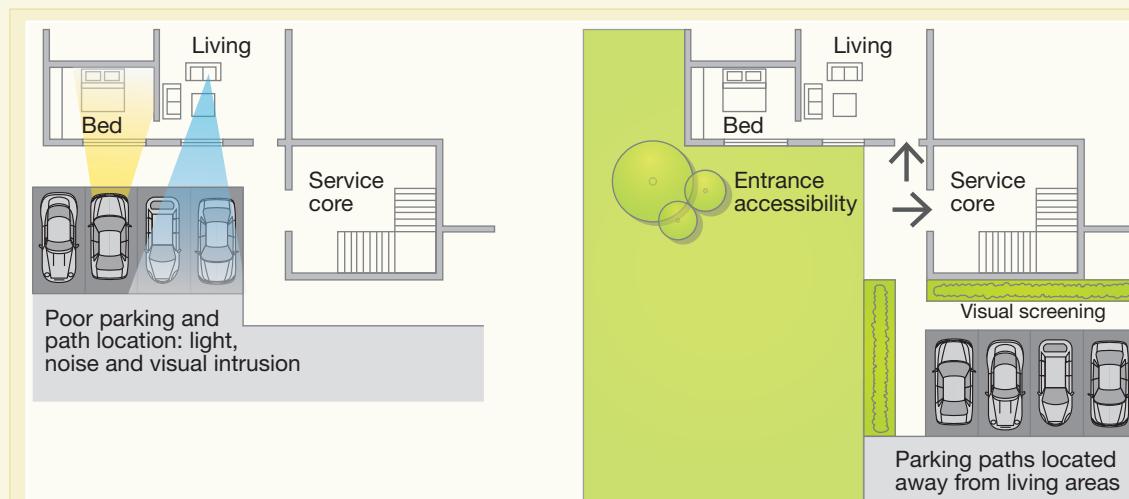

Location of parking is inappropriate and has adverse impacts on the residents.

Car parking is well located, reducing impact on residents and providing convenient building access.

**Figure 51:** Incorporate parking spaces and manoeuvring areas into the design of the building so they are not located in close proximity to habitable rooms and openings at ground level.



[Return to contents page](#)

### 6 Design elements of the R-Codes Volume 1 – Site planning and design

General

Specific design elements

6.1 Outdoor living areas

6.2 Landscaping

6.3 Parking

6.4 Design of car parking spaces

6.5 Vehicular access

6.6 Site works

6.7 Retaining walls

6.8 Stormwater management

6.9 Pedestrian access – Part 5 of R-Codes Volume 1

### General guidelines

## 6.5. Vehicular access

[\(Clause 5.3.5 of R-Codes Volume 1\)](#)

### Location of parking spaces and crossovers

Car parking spaces, manoeuvring areas and access ways are potentially intrusive, physically, visually and acoustically. This is particularly evident for [grouped](#) and [multiple dwelling developments](#) where multiple parking spaces and access is required. Car parking consumes space and does not generally make a positive contribution to the streetscape. Consequently, location is a major factor in amenity as well as security and safety.

The issue of location of [carports](#) and [garages](#) in relation to the [primary street setback area](#) is dealt with in [clause 5.2.1](#) of the R-Codes Volume 1. The advantages of not having vehicle access directly from the primary street are identified in [clause 5.3.5](#) of the R-Codes Volume 1 and include:

- the streetscape will be less dominated by carports, garages and parked vehicles;
- there will be fewer [driveways](#) and so more useable space for [street](#) trees and kerbside parking for visitors; and
- there will be fewer conflicting movements of vehicles, pedestrians and cyclists.

The number of driveway crossovers from [residential development](#) into the street affects the quality of a streetscape (refer to figure 53).

Too many crossovers cause a loss of kerbside parking space, lack of space for street trees and furniture, interruption to pedestrian use of footpaths and increased hazards for cyclists.

To achieve a good balance between on-street and off-street parking design it is important to reduce the number of driveway crossovers by integrative access design, especially for multiple dwelling development. This will allow a greater run of uninterrupted kerbside available for street parking, much of which can be used by visitors.

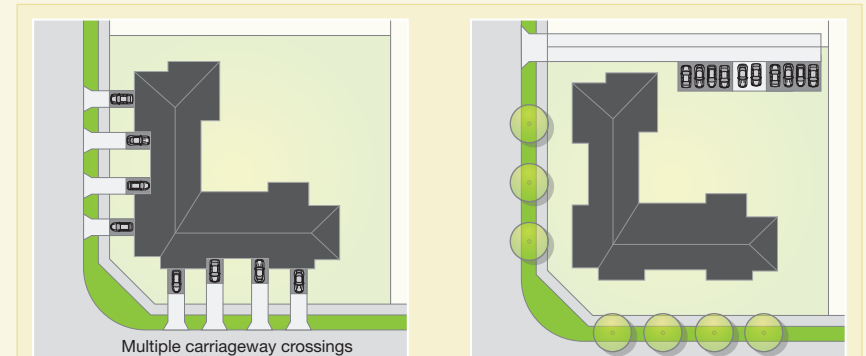

Individual crossovers should not be provided.

Part of the site is given up for the creation of a shared access way. Shared access arrangements with adjoining properties should be investigated where appropriate.

**Figure 53:** Vehicle access should be designed to minimise the impact on the street network and provide for safe ingress and egress from the site.

Access to on-site parking is encouraged to be from a [right-of-way](#), where available for lawful use, or from a [secondary street](#). Access is to be provided from the primary street only where there is no secondary street or right-of-way.

**Locate vehicle access and accommodation to the rear of the site where possible. Encourage shared access by utilising a single crossover with adjoining development**

By minimising the number of vehicle access points along the streetscape, there is more opportunity for on-street parking and the retention or improvement of the streetscape character. Vehicle access should not double as pedestrian access. Pedestrian access arrangements should be provided in a location that is separated from vehicle movements (refer to figure 54).





## 6 Design elements of the R-Codes Volume 1 – Site planning and design

[Return to contents page](#)

### 6 Design elements of the R-Codes Volume 1 – Site planning and design

General

Specific design elements

6.1 Outdoor living areas

6.2 Landscaping

6.3 Parking

6.4 Design of car parking spaces

6.5 Vehicular access

6.6 Site works

6.7 Retaining walls

6.8 Stormwater management

6.9 Pedestrian access – Part 5 of R-Codes Volume 1

#### General guidelines

The location of the crossover should be provided in response to the nature of the [street\(s\)](#) onto which the [development](#) fronts. If there is more than one [street frontage](#) (including rear lanes), the vehicle access should be provided onto the street that carries the lowest volumes of traffic. However, the crossover should also be provided in a location that provides clear sight lines in both directions along the street, is separated as far as possible from any intersection, does not impact on on-street services such as public transport stops, accounts for posted speed limits, and is designed in accordance with any built-up median.

Vehicles can be slowed by creating a clearly different environment at the entry of the [site](#). This can be achieved through the use of texture in the paving surface, creating a perceived narrowing of the carriageway, and use of planting and short access legs to limit the ability for cars to pick up speed across the area. Through appropriate design, the use of speed humps can be avoided.

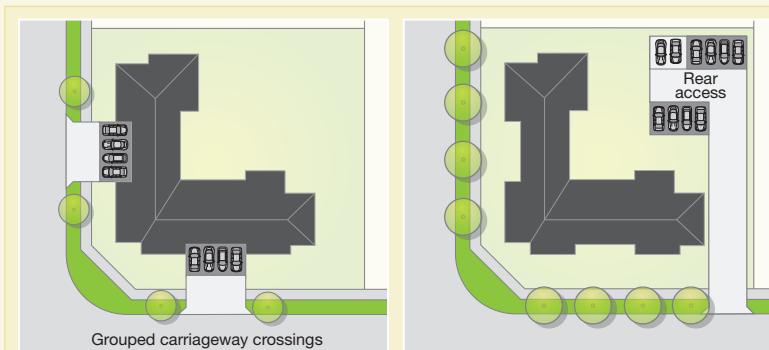

*Car parking is provided in a manner that increases the proportion of the frontage that is dedicated to vehicular access.*

*Car parking is located away from view of the street and accessed via a single consolidated access point.*

**Figure 54:** Consolidate vehicular access points to reduce impact on streetscape.

#### Part 5 only

### 6.5.1 Vehicular access – Part 5 of R-Codes Volume 1 (Clauses 5.3.5 of R-Codes Volume 1)

Vehicular access is required to include [driveways](#) of an adequate width to allow for the movement of vehicles as per 5.3.5 of the R-Codes Volume 1.

A driveway width of 3m is adequate for driveways serving four [dwellings](#) or less but a minimum of 4m that is designed to allow for two-way access is required for driveways serving five or more dwellings.

Note that a driveway is also required to be [setback](#) 0.5m from a side [lot boundary](#) for purposes not limited to stormwater management, [landscaping](#) and utilities. The total minimum width for vehicle access may therefore be required to be at least 4m or 5m to allow 0.5m on either side of a driveway between two lot boundaries.

For a proposed [battlease lot](#), where vehicle access is within the battlease leg, the proposal will also be subject to the requirements of [Development Control Policy 2.2 Residential Subdivision](#).



[Return to contents page](#)

### 6 Design elements of the R-Codes Volume 1 – Site planning and design

General

Specific design elements

6.1 Outdoor living areas

6.2 Landscaping

6.3 Parking

6.4 Design of car parking spaces

6.5 Vehicular access

6.6 Site works

6.7 Retaining walls

6.8 Stormwater management

6.9 Pedestrian access – Part 5 of R-Codes Volume 1

General guidelines

### 6.6 Site Works

[\(Clause 5.3.7 of R-Codes Volume 1\)](#)

#### Retaining the natural topography and ground level

Variations in topography make an important contribution to local character and to a sense of place.

In many locations, the land form (topography) allows views out of the locality. These views are highly valued and can only be optimised, that is, shared by the maximum number of [dwellings](#), by respecting the natural topography and maintaining a consistent scale in [building](#). This also has an effect on the potential for privacy and overlooking, which is an issue dealt with in [clause 5.4.1](#) of the R-Codes Volume 1 (refer to section 7.1 of guidelines).

The extensive earth working of residential [sites](#) removes remnant vegetation, disturbs soil profiles, expends energy and creates greenhouse gas emissions. It also adds to the cost of housing.

[Development](#) of land should avoid major interference with the natural or pre-existing site levels, to preserve the natural topography and minimise development costs. [Natural ground level](#) is the level of land before land development has occurred or that resulting from the pre-existing development.

Because much of the State's housing was built before accurate contour mapping was available, it is often not possible to know precisely the levels that preceded development. In these cases, it may be necessary to refer to other evidence in order to establish, as closely as possible, the relevant levels.

Housing design which proposes extensive excavation, fill and re-contouring of a site, without regard to neighbouring properties and their amenity, should not be supported. The R-Codes Volume 1 call for skilful and site-sensitive design to make the best of the natural terrain, in turn resulting in diversity of housing styles and a sense of place and neighbourhood identity.

#### Take advantage of the natural topography for view sharing and retention of the visual impression of the natural level of the site

By stepping a building to correspond with the natural topography, less cut and fill is required and the visual impression of the natural level of the site is retained (refer to figure 55).

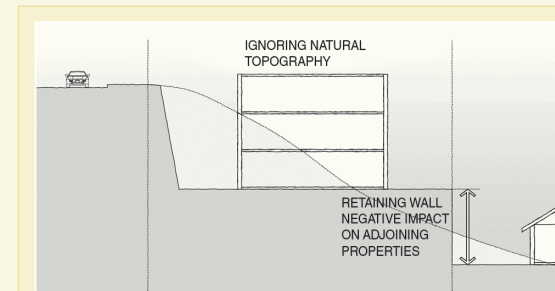

*Development ignores the natural slope of the land, resulting in diminished character of the area and increased development impact.*

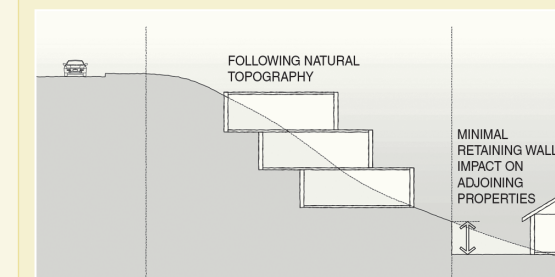

*Development acknowledges the natural slope of the land and minimises impact on adjoining land.*

**Figure 55:** Development on steep or undulating sites should be designed to minimise the amount of cut and fill required. Buildings should have a form that responds to the natural topography of the area.



## 6 Design elements of the R-Codes Volume 1 – Site planning and design

[Return to contents page](#)

### 6 Design elements of the R-Codes Volume 1 – Site planning and design

General

Specific design elements

6.1 Outdoor living areas

6.2 Landscaping

6.3 Parking

6.4 Design of car parking spaces

6.5 Vehicular access

6.6 Site works

6.7 Retaining walls

6.8 Stormwater management

6.9 Pedestrian access – Part 5 of R-Codes Volume 1

General guidelines

### Changes to topography at subdivision

In cases where the original subdivision involved changes from the natural levels, the relevant levels to take are those established at subdivision, prior to buildings being erected.

It is common for new finished levels to be established through the building of retaining walls at boundaries. Where this occurs, and for the purposes of establishing boundary [setbacks](#) and heights, retaining walls may be regarded in the same light as natural topographical features. Proposed changes of level at subdivision should be examined just as carefully as level changes via development.

### Excavation and retaining walls

Development below [natural ground level](#) only rarely affects neighbouring [sites](#), although it may be necessary to take account of the location of essential services, particularly where protected by a registered easement. By contrast, filling above natural ground level, especially where, it results in replacing a natural slope with level ground and retaining walls, is usually visually prominent.

Excavation below natural level is not usually as visually obtrusive as filling above natural level. Consequently, excavation behind the [street setback](#) line is normally acceptable, provided the resulting spaces and rooms conform to BCA standards.

### Minimise impacts on neighbours and public streetscape in the design and selection of materials for retaining walls

Where a [building](#) cannot be designed to correspond to the natural topography, the result is often retaining walls that are visually prominent. The design of these walls should minimise their height and length through terracing and articulation. Materials should be selected for the walls that are visually interesting and integrated into the surrounding [landscape](#).

### 6.7 Retaining walls

[\(Clause 5.3.8 of R-Codes Volume 1\)](#)

Planning considerations are as per site works in section 6.6 of the guidelines.

#### 6.7.1 Retaining walls – Part 5 of the R-Codes Volume 1

[\(Clause 5.3.8 of R-Codes Volume 1\)](#)

Part 5 only

Any significant filling of land is likely to have a potential impact on [adjoining properties](#) concerning overlooking and overshadowing ([clause 5.4.1](#) of the R-Codes Volume 1 and section 7.1 of the guidelines). For these reasons, retaining [walls](#), unless they are 0.5m in height or less, should be treated as though they were [building](#) walls and should be set back from property boundaries accordingly.

Retaining walls that are provided as part of an approved subdivision or part of a previous [dwelling](#) which establish levels are excluded from these requirements. For the purposes of the R-Codes Volume 1, such walls are regarded as representing the finished level of the [site](#) prior to new [development](#).

#### Calculating retaining wall setbacks

[Clause 5.3.8 C8.1](#) of the R-Codes Volume 1 requires retaining walls higher than 0.5m to be set back in accordance with [Table 1](#). To determine this [setback](#) and meet this [deemed-to-comply](#) provision, the retaining wall is:

- considered to be a wall with a [major opening](#) and a height of 2.4m plus the height of the retaining wall ([table 2b](#) – boundary setbacks); or
- the retained area is screened to prevent views of neighbouring property and is set back in accordance with the requirements for a [wall height](#) of 1.8m without major openings in addition to the height of the retaining wall ([table 2a](#) – boundary setbacks).



[Return to contents page](#)

### 6 Design elements of the R-Codes Volume 1 – Site planning and design

General

Specific design elements

6.1 Outdoor living areas

6.2 Landscaping

6.3 Parking

6.4 Design of car parking spaces

6.5 Vehicular access

6.6 Site works

6.7 Retaining walls

6.8 Stormwater management

6.9 Pedestrian access – Part 5 of R-Codes Volume 1

### General guidelines

## 6.8 Stormwater management

[\(Clause 5.3.9 of R-Codes Volume 1\)](#)

Water-sensitive urban design is recognised as an important aspect of environmental conservation and sustainable [development](#). It is critical to land subdivision, but also in relation to development of individual [sites](#).

Important aspects that should be taken into account are:

- managing water balance by encouraging infiltration and groundwater recharge;
- ensuring that the quality of water leaving a site is acceptable; and
- encouraging water conservation, including re-use of stormwater and minimisation of mains supply water for [landscaping](#).

At this stage, widespread re-use of recycled water is limited, however, third pipe systems are progressively becoming feasible in new developments and redevelopment areas. It is possible, nevertheless, to contain all stormwater on-site in almost all [residential developments](#), ensuring both recharge of groundwater and the avoidance of discharge into public drainage systems.

Exceptions to this will be in:

- areas where soil conditions make on-site infiltration or absorption achievable;
- some inner city areas where the density of development precludes on-site discharge; and
- areas where the intensity and duration of precipitation makes significant on-site absorption impractical.

## Recover stormwater for use within the site where practical

Stormwater can be collected and stored on-site for irrigation or grey water systems (for example, for toilets). It can also be directed to root zones to reduce the need for additional irrigation. It is easier to plan for stormwater collection at the onset of planning a [building](#) rather than trying to retrofit a system afterwards (refer to landscaping provision [5.3.2](#) of R-Codes Volume 1 and section 6.2 of guidelines).

## Minimise impacts of stormwater release on adjoining sites

Where it is not practical for stormwater to be recovered, stormwater should be slowly released from the site through retardation systems or returned to the ground via soak wells or leaching pits.

### Part 5 only

## 6.9 Pedestrian access – Part 5 of the R-Codes Volume 1

[\(Clause 5.3.6 of R-Codes Volume 1\)](#)

### Pedestrian and vehicular access points are to be adequately separated

There are many preventable injuries and fatalities which involve cars and children in [driveways](#). The location of vehicular access points should be separated from pedestrian access points, to reduce the potential for conflicting movements.

Safe pedestrian access from the [street](#) or car parking to private [dwellings](#) is equally important for [single houses](#), [grouped](#) and [multiple dwelling developments](#).

Accordingly, the R-Code Volume 1 provisions are designed to encourage the provision of good sight lines, and ensure a smooth uninterrupted path of travel between car parking and the [building](#).



## 7 Design elements of the R-Codes Volume 1 – Building design

[Return to contents page](#)

### 7 Design elements of the R-Codes Volume 1 – Building design

General

Specific design elements

7.1 Visual privacy

7.2 Solar access for adjoining sites

7.3 Outbuildings

7.4 External fixtures

7.5 Utilities and facilities

### General

#### [\(Clause 5.4 of R-Codes Volume 1\)](#)

This design element deals with matters that affect [building](#) design, including the protection of privacy and solar access, meaning primarily the prevention of areas being overlooked by neighbours or overshadowed by buildings, which has become a significant issue in recent years. In addition to the building itself, many forms of [incidental development](#) such as external fixtures and [outbuildings](#) can also have visual impacts.

The level of impact upon the character and density of the area is to be considered in relation to building design. The level to which a proposal meets other requirements (for example, height and [setback](#) requirements) might also assist in determining what reasonable action is needed in managing impacts on privacy and solar access.

With increases in density, there is an expectation that there will be a commensurate increase in impact of buildings on privacy and solar access. There is an expectation of greater tolerance, and therefore allowance, of these impacts at higher density. A level of impact not appropriate in an area of low density is likely to be more acceptable, and more tolerated, at higher densities.

### Specific design elements

#### [\(Clause 5.4 of R-Codes Volume 1\)](#)

This element deals with the following provisions of part 5 of the R-Codes Volume 1:

- 7.1 Visual privacy;
- 7.2 Solar access for adjoining sites;
- 7.3 Outbuildings;
- 7.4 External fixtures; and
- 7.5 Utilities and facilities.



[Return to contents page](#)

### 7 Design elements of the R-Codes Volume 1 – Building design

General

Specific design elements

7.1 Visual privacy

7.2 Solar access for adjoining sites

7.3 Outbuildings

7.4 External fixtures

7.5 Utilities and facilities

#### General guidelines

### 7.1 Visual privacy

#### [\(Clause 5.4.1 of R-Codes Volume 1\)](#)

It is recognised that side [setbacks](#) alone cannot achieve absolute visual privacy because the setback distances required are much greater than those which can be feasibly provided in an urban area.

Setbacks need to be complemented by thoughtful design and supplemented by various [screening](#) measures, as appropriate.

Privacy is a valid cause for concern and plays an important role in residential amenity. However, aside from cases of poor design, there is a large degree of subjectivity, often related to cultural perceptions and concerns.

A sufficient level of privacy must be reached by good design to satisfy reasonable concerns. It is not the intent of the R-Codes Volume 1 to require 100 per cent privacy at the expense of inconsistent [building](#) orientation, access to daylight, winter sun, ventilation, security or poor relationship to neighbours.

#### Sources of overlooking

Overlooking from areas on or close to [natural ground level](#) is not subject to control in terms of [clause 5.4.1](#) of the R-Codes Volume 1. This applies equally to [outdoor living areas](#) and [habitable rooms](#) which are less than 0.5m above natural ground level. The basis for this is that the view from such areas can be readily limited by a standard 1.8m high boundary fence, and while this may not restrict sight lines in an upward direction, the impact of overlooking [major openings](#) to habitable rooms or [balconies](#) situated above natural ground level would be limited.

While it may be possible to overlook an [adjoining property](#) from many situations, [clause 5.4.1](#) only seek to control overlooking between:

- [active habitable spaces](#) and outdoor living areas of the [development site](#); and
- the habitable rooms and outdoor living areas of the adjoining residential properties.

#### Overlooking and the cone of vision for privacy design

The impact of a particular [development](#) on the privacy of a neighbouring property can be assessed by applying the concept of a [cone of vision](#) at any point where a person is likely to be able to look on to that property, as illustrated by [figure series 10](#) of the R-Codes Volume 1.

The relevance of the cone of vision is readily apparent. The cone of vision is defined by the extent of the opening ([figure 10a](#) of the R-Codes Volume 1). The concept of a cone of vision is a useful tool also for the design of screening devices.

For the purposes of assessing setbacks and privacy provisions, all balconies, [verandahs](#), terraces and other outdoor living areas raised more than 0.5m above natural ground level should be regarded as habitable rooms with a [wall height](#) of 2.4m above the floor level. All such areas, together with active indoor spaces, should be designed to minimise overlooking of neighbouring properties.

Overlooking from bedrooms and studies, which may be occupied infrequently, mainly at night, without noise, and by relatively few people, is more easily tolerated than overlooking from active areas.

Of most concern are [active habitable spaces](#), for example, living rooms, kitchens, activity rooms, balconies and outdoor living areas that are at levels higher than 0.5m above [natural ground level](#).

#### Prevention of overlooking

There are four basic ways of preventing or ameliorating overlooking:

- designing windows, balconies and decks to face away from boundaries with neighbouring properties, especially side boundaries;
- providing greater than normal setbacks, to achieve an effective privacy separation distance;
- providing intervening screening; or
- ensuring that overlooking windows cannot be opened and are opaque or highlight windows.

Often the most effective results will come from a combination of these.



[Return to contents page](#)

### 7 Design elements of the R-Codes Volume 1 – Building design

General

Specific design elements

- 7.1 Visual privacy
- 7.2 Solar access for adjoining sites
- 7.3 Outbuildings
- 7.4 External fixtures
- 7.5 Utilities and facilities

#### General guidelines

Effective location of [major openings](#) and outdoor [active habitable spaces](#) to avoid overlooking is preferred to the use of [screening](#) devices or obscured glass.

Where these are used, they should be integrated with the [building](#) design and have minimal impact on residents' or neighbours' amenity.

Where opposite windows are offset from the edge of one window to the edge of another, the distance of the offset should be sufficient to limit views into adjacent windows (refer to figure 56 and 57).



*Screening devices used to provide for increased visual privacy between developments.*

**Figure 56:** Angled louvre blades on balconies near the property boundary reduce the potential for overlooking while allowing natural daylight into the unit.



*Screening devices used to limit views between internal spaces of one dwelling and the balcony of the adjoining building.*

**Figure 57:** Screening devices allows developments within close proximity to mitigate direct overlooking.

#### Privacy separation distances

A desirable degree of privacy requires a significant separation between the areas concerned, in most cases greater than the [lot boundary setbacks](#) required under [clause 5.1.3](#) of the R-Codes Volume 1. In practice, some degree of compromise is necessary.

Because it is not always possible to predict how a neighbouring [site](#) may be developed in the future, privacy separation distances can most realistically be applied between the proposed [development](#) and the property boundary, that is, as line of direct sight setbacks. The way in which setbacks should be determined is illustrated in [figure 10c](#) of the R-Codes Volume 1 using the [cone of vision](#) (refer to figure 58).

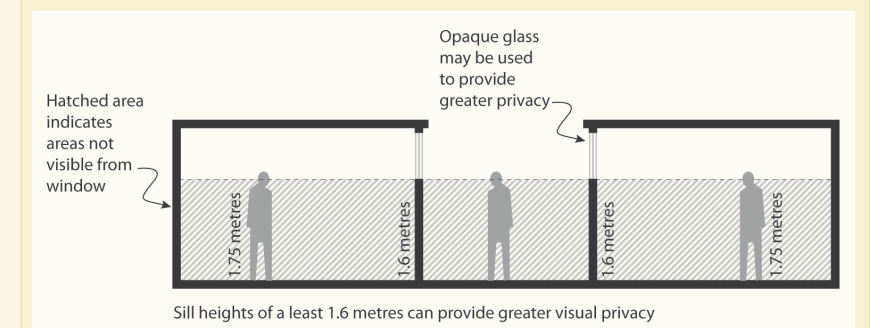
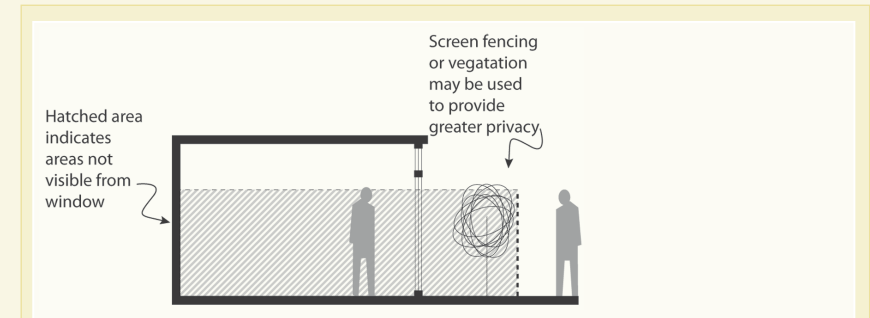

**Figure 58:** Privacy design

[Return to contents page](#)

7 Design elements of the R-Codes Volume 1 – Building design

General

Specific design elements

7.1 Visual privacy

7.2 Solar access for adjoining sites

7.3 Outbuildings

7.4 External fixtures

7.5 Utilities and facilities

General guidelines

The R-Codes Volume 1 provide a set of privacy [setbacks](#), based on these considerations, to operate in the absence of detailed and acceptable consideration of the use and [development](#) of affected properties. These are set out as [deemed-to-comply](#) provisions, which do not require the discretion of the [decision-maker](#). For that reason, they are conservative, providing a relatively high level of protection from overlooking, but not absolute, protection.

In many cases, more effective and mutually beneficial outcomes can be achieved through the application of good design, directed at meeting the relevant [design principles](#) (Refer to figure 59).

Acceptable point-to-point privacy distances can be calculated by aggregating the privacy setbacks of the deemed-to-comply provisions.

In the case of [active habitable spaces](#), including [outdoor living areas](#) and [balconies](#), an effective privacy separation distance would be of the order of 15m or more. Clearly, this is not realistically achievable. An acceptable compromise setback, where intervening [screening](#) is not provided, would be in the order of 7.5m for active habitable spaces, 6m for living areas and 4.5m for bedrooms in areas codes R50 or less and 6m, 4.5m and 3m respectively in areas coded higher than R50.

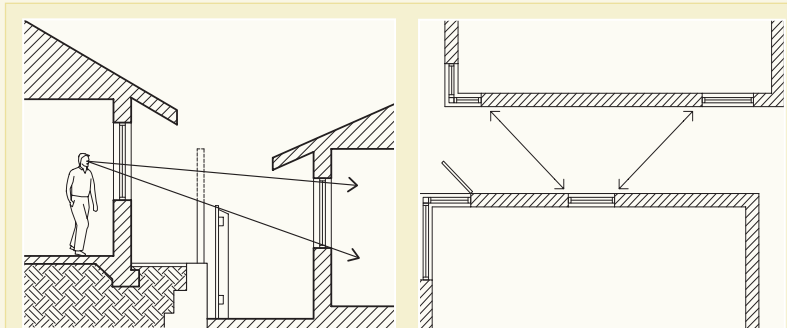

**Figure 59:** Increased fence heights or offsetting of windows are measures that may prevent overlooking.

The deemed-to-comply provisions for this design element provide for the setback of [major openings](#) in the [cone of vision](#) or permanent screening, as the alternative measure to protect the privacy of [adjoining property](#). Measurement of setback distances is to be taken from the major opening to the boundary, and accordingly, should be measured from the external face of the opening. This is illustrated in [figure 10b](#) of the R-Codes Volume 1.

The measurement of privacy setbacks varies from that used for normal boundary setbacks only in that the line of the measurement in the case of privacy setback is to be based on the cone of vision. Accordingly, there will be situations in which the measurement is not at right angles to the boundary. It is important to understand that the setback distances included in the deemed-to-comply provisions represent minimum separation, which will be measured to the closest point of the boundary in the cone of vision.

Where a proposed development involves a departure from the deemed-to-comply provisions with respect to the separation distances specified in [clause 5.4.1](#), assessment should be undertaken in accordance with the [design principle](#), as illustrated by Figure 60. This will involve consultation with potentially affected adjoining property owners, who should be requested to provide comment on the proposal, and information about the location of any [habitable room](#), windows or outdoor living areas which may be affected.

Assessment of applications which involve a proposal that addresses the design principles generally will require plotting the position of the adjacent [dwelling](#), the location of any

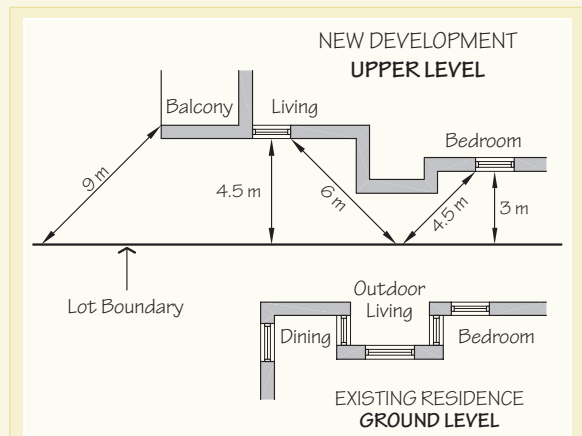

**Figure 60:** Example of a development that would not be deemed-to-comply, however, could meet the design principle.



## 7 Design elements of the R-Codes Volume 1 – Building design

[Return to contents page](#)

### 7 Design elements of the R-Codes Volume 1 – Building design

General

Specific design elements

7.1 Visual privacy

7.2 Solar access for adjoining sites

7.3 Outbuildings

7.4 External fixtures

7.5 Utilities and facilities

#### General guidelines

major openings to [habitable rooms](#) and any associated [outdoor living areas](#). This will enable identification of areas and openings which fall in the [cone of vision](#).

Evaluation of proposals should take into account only the potential impact of sight lines within the cone of vision where separation distances do not meet the deemed-to-comply provisions. Where separation distances accord with the provisions with respect to the cone of vision, the standard of privacy protection is satisfactory.

#### Screening for privacy

[Screening](#) can be employed to limit the cone of vision, and therefore, the privacy distances which otherwise would be required. However, it is important to note that in order for such screening to be taken into account for the purposes of the [deemed-to-comply](#) provisions, it must be regarded as permanent. Proposals that address the [design principles](#) would provide for alternative solutions from the deemed-to-comply provisions, and in such circumstances, alternatives to permanent screening may be considered, subject to appropriate consultation with relevant [adjoining property](#) owners.

Privacy screening can occur in various forms, including:

- vegetation
- permanent elements such as fences, balustrades and louvres
- translucent or opaque (that is, non-transparent) glazing and other similar materials (refer to figure 61).

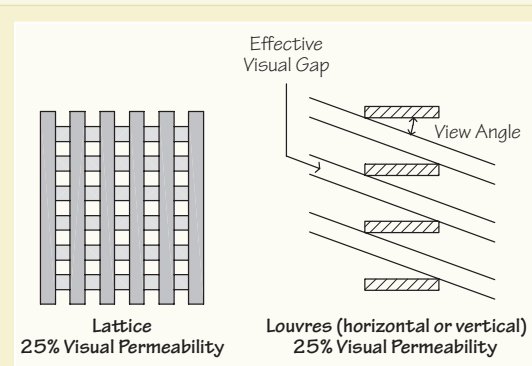

**Figure 61:** Example of screening by which visual permeability can be limited. Note that a view angle of 45 degrees to the side is the limit of the cone of vision as defined in the R-Codes Volume 1, and no screening is required outside these limits.

#### Vegetation

Vegetation in the form of screen planting or selective placement of suitable trees or shrubs can provide effective screening for privacy control, and also can enhance development and residential amenity. A drawback of this mitigation is that potentially affected property owners and occupiers may need assurance that the vegetation will remain in place, and any such screening should be assessed in terms of the design principle and in consultation with relevant property owners.

Subject to consultation with the adjoining owner, the necessary planting may be located on the [development site](#), and would be the subject of a condition of planning approval to run with the land. As an alternative, arrangements might be made for the developer to provide or contribute towards the cost of screen planting on the affected property, which would then become the responsibility of the affected property owner to maintain.

#### Fences and balustrades

Fences and balustrades are effective forms of screening and require little further explanation where they take the form of a solid [wall](#). The design and location of such features must not infringe on other relevant requirements for development, such as [setbacks](#), shading, day lighting and in the case of fences, the requirements of the *Dividing Fences Act 1961*, and associated local laws.

Screening may be perforated to some degree to allow the circulation of air, providing it meets the objective of protecting visual privacy. Because of the absence of a prescriptive standard applicable to partial screening, such proposals generally should be assessed in terms of the design principles and in consultation with any potentially affected property owners.

Perforations should constitute no more than about 20 per cent of the total surface area, with an upper limit of 25 per cent. However, it also is important that the size of individual gaps are not such as to prejudice the visual privacy of adjoining properties, and a maximum 50mm visual gap is suggested as reasonable. This compares with a minimum gap of 50mm referred to in the definition of [visually permeable](#).

[Return to contents page](#)

### 7 Design elements of the R-Codes Volume 1 – Building design

General

Specific design elements

7.1 Visual privacy

7.2 Solar access for adjoining sites

7.3 Outbuildings

7.4 External fixtures

7.5 Utilities and facilities

#### General guidelines

In the case of lattice [screening](#), the [visual permeable](#) definition would be met by 50mm slats at a spacing of 50mm (that is 75 per cent coverage with gaps no greater than 50mm). Where fixed louvres are used either for vertical or horizontal screening, the spacing required to meet the same visual permeability standards will depend on the angle of view and the width of the louvre blades (refer to figure 62).

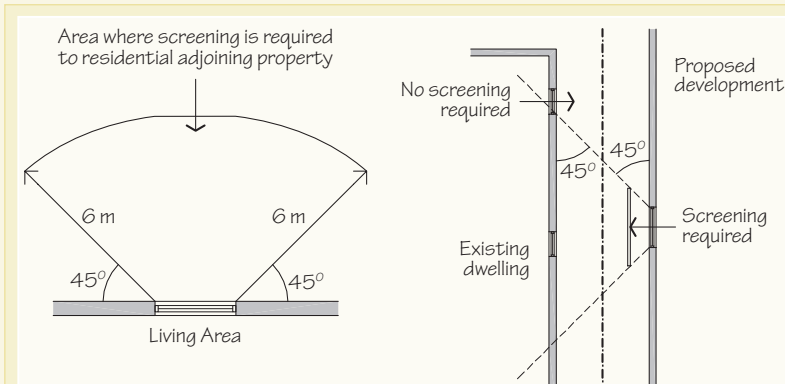

**Figure 62:** Horizontal screening.

Louvres, which are proposed to be relied on for screening, must be fixed or have a physical and permanent limitation on opening, to ensure the level of visual permeability does not exceed the specified standard. Such standards may be subject to a discretionary variation taking into consideration any comment and/or agreement from the relevant [adjoining property](#) owner.

### Translucent or opaque

The use of this form of screening generally does not involve the exercise of any discretion on the part of the [decision-maker](#). However, where such measures take the form of sheet glass of the type which could be easily replaced, as distinct from glass block work for example, it generally would be appropriate to apply a condition to ensure the screening remains in place (for example, in the event of breakage, it is replaced to meet the same specification). Because of the limitations on the use of planning conditions through the building permit process, this necessitates an application for planning approval.

### Building to boundaries

Privacy may be enhanced, for both the development and its neighbour, by building a portion of the [dwelling](#) up to the common boundary as provided in [clause 5.1.4](#) of the R-Codes Volume 1. This overcomes the problem of overlooking from that [wall](#), and in most cases allows more freedom of design on the [site](#) to ensure privacy for [outdoor living areas](#) and windows. However, the use of boundary walls does need to consider other aspects of design and neighbour amenity, such as the possibility of overshadowing neighbouring dwellings or outdoor living areas.

#### Part 5 only

### 7.1.1 Visual privacy – Part 5 of the R-Codes Volume 1

[\(Clauses 5.4.1 of R-Codes Volume 1\)](#)

#### Location of protected areas

[Habitable rooms](#) and outdoor living areas are identified in [clause 5.4.1](#) of the R-Codes Volume 1 being the areas which are to be the subject of privacy protection. In the case of habitable rooms, [major openings](#) should be the focus of attention, while in the case of outdoor living areas, priority should be given to areas required to be allocated for this purpose under [clause 5.3.1](#) of the R-Codes Volume 1 (an area of [open space](#) directly accessible from a living area and having a minimum dimension of 4m).



[Return to contents page](#)

### 7 Design elements of the R-Codes Volume 1 – Building design

General

Specific design elements

7.1 Visual privacy

7.2 Solar access for adjoining sites

7.3 Outbuildings

7.4 External fixtures

7.5 Utilities and facilities

Part 5 only

Protection from overlooking is not required for [open space](#) other than that defined as [outdoor living areas](#). Protection from overlooking generally is not necessary for extensive areas of garden which are well separated from the [dwelling](#) to which they relate. Those outdoor areas likely to be occupied for extended periods of time, and where it is reasonable to expect a relatively high degree of privacy, should be the focus of attention in terms of any restrictions to be applied to overlooking from adjoining properties.

A lesser need for privacy protection is usual in the case of front gardens and areas visible from the [street](#), and this principle should also be carried over to other public places, such as parks. The basis for this acceptance is that control of overlooking for areas visible from public places would be largely ineffective in terms of privacy protection and also could limit outlook over, and surveillance of, the public places themselves, thus compromising safety and security.

The [deemed-to-comply](#) provisions are limited to protection of areas of any [adjoining property](#) behind its [street setback](#) line.

While the deemed-to-comply provisions do not seek to protect areas in front of the adjoining property's street setback line, a proposal that addresses the [design principles](#) may need to be considered in the case of corner [lots](#) adjacent to a [development site](#).

Prior to development of a corner lot in a greenfield area, the determination of [primary](#) and [secondary streets](#) will generally be unknown and, therefore, deemed-to-comply provisions which relate to the location of the street setback line will be undefined. This indicates the need for the exercise of discretion, and in these circumstances, a proposal that addresses the design principles would be appropriate. In such cases consultation with the relevant adjoining property owners may be required to inform the [decision-maker](#). In circumstances where an outdoor living area (associated with a corner lot) is situated adjacent to the secondary street [frontage](#) and where the street setback line (generally taken to be the line which delineates the street setback area) is only 1.5m from the street alignment, some difficulty would be encountered in meeting the deemed-to-comply provisions. Similar difficulties may arise where the dwelling on a corner [site](#) is built up to the secondary street setback (1.5m) with [major openings](#)

facing the side boundary and subject to overlooking from an adjoining dwelling situated at its standard setback.

Where there is an [outdoor living area](#) adjacent to the secondary street, or major openings in an area which otherwise might have been the [primary street setback area](#), application of the normal deemed-to-comply provisions could impose unreasonable constraints on the adjoining [development](#), for example, no front [balconies](#) or major openings to habitable spaces above ground level. In such circumstances, consideration should be given to the design principle, with a view to limiting potential conflicts, however, the concessional provisions which allow for reduced secondary street setbacks for corner lots should not be allowed to unduly prejudice development of adjoining property.

### Taking neighbouring properties into account

The proponent and the [decision-maker](#) should take into account the effect of the new development on existing or proposed dwellings on adjoining properties.

Design of new development should avoid overlooking into adjacent [habitable room](#) windows, especially of living rooms, balconies, terraces and other outdoor living spaces which are frequently occupied.

Protection from overlooking has high priority where the proposed dwelling has limited outdoor living space, and especially where its location is fixed, for example, adjacent to indoor living areas. Protection from overlooking is not necessary for extensive areas of garden, especially where these can provide their own vegetation screening (refer to figures 63 and 64).

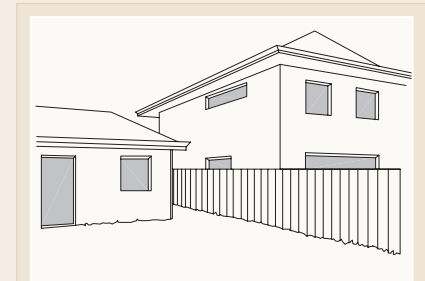

**Figure 63:** Upper windows facing the rear garden are generally acceptable.

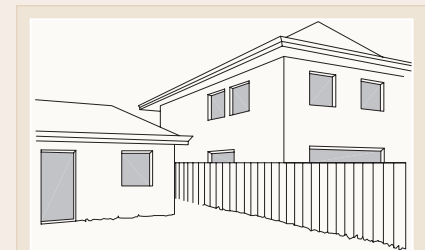

**Figure 64:** Upper windows facing a neighbouring property are generally not acceptable.



[Return to contents page](#)

### 7 Design elements of the R-Codes Volume 1 – Building design

General

Specific design elements

7.1 Visual privacy

7.2 Solar access for adjoining sites

7.3 Outbuildings

7.4 External fixtures

7.5 Utilities and facilities

Part 5 only

#### Application of design principles

Minimisation of overlooking should not be interpreted as an absolute prohibition on visual interaction. The objective for this element is to minimise the impact of [development](#) on the visual privacy of nearby residents. It is clear that absolute protection of privacy is not realistically achievable. Limits to the protection of privacy are also borne out by reference to the general approach to separation, as an alternative to the interruption of sight lines, to achieve an acceptable compromise.

With reference to the application of the [design principles](#) the focus should be on what constitutes a reasonable level of privacy in the circumstances, and what is realistically achievable. This may vary depending on the circumstances, with generally higher levels of visual privacy achievable in low-density areas than is practical in higher-density areas. Differing community expectations in different situations should also be kept in mind.

In some cases, there may be mutual benefit to be gained by a relaxation of the privacy standards, and subject to consultation with potentially affected property owners, alternatives should be considered in this light. For example, where adjoining [sites](#) are orientated east to west with views or outlook to the north, relaxation of privacy standards may enable a better design outcome in which solar access to, and views from, the north side of the site are maximised.

Applicants seeking approval through an application for a proposal that addresses the design principles are required to provide a written submission in support of the proposal. Where a [major opening](#) to an [active habitable space](#) is proposed closer to the nearest point of common boundary in the [cone of vision](#) than the [setbacks](#) specified in [deemed-to-comply clause 5.4.1 C1.1i](#) of the R-Codes Volume 1, the following additional information is to be provided, in accordance with [clause 3.3.1\(b\)](#) of the R-Codes Volume 1:

- The position and dimensions of any [balcony](#) or major openings to any [active habitable space](#) in any [wall](#) of an adjoining [building](#) which is visible from the [development site](#) and is located within 6m of a boundary of the development site.
- The position and level of any accessible area (for example, lawn, paving, decking, [balcony](#) or swimming pool) on any [adjoining property](#) and within 6m of a boundary of the development site.
- Provision of additional or marked-up plans and sections showing the [cone of vision](#) and critical lines of sight from those major openings as they relate to the adjoining property.
- Details of [screening](#) or other measures proposed to be used to reduce overlooking.



## 7 Design elements of the R-Codes Volume 1 – Building design

[Return to contents page](#)

### 7 Design elements of the R-Codes Volume 1 – Building design

General

Specific design elements

7.1 Visual privacy

7.2 Solar access for adjoining sites

7.3 Outbuildings

7.4 External fixtures

7.5 Utilities and facilities

### General guidelines

## 7.2 Solar access for adjoining sites

[\(Clause 5.4.2 of R-Codes Volume 1\)](#)

Western Australia encompasses a variety of regions with different climates, ranging from temperate in the south-west to hot-arid in the interior to hot-humid in the north (refer to figure 65). Consequently, it is not possible for the R-Codes Volume 1 to adopt a uniform set of climatic design requirements for [residential development](#). It is possible, however, to express general guidelines and principles and to allow local planning as the most appropriate avenue to introduce this aspect of design control to suit local conditions.

A majority of new [development](#) occurs in, or close to, the Perth metropolitan region and so there is some value in establishing standards suitable for the Perth coastal climate.

Accordingly, much of the guidance regarding solar access applies directly to the Perth metropolitan region, and appropriate adjustments need to be made for other regions.

While specific [deemed-to-comply](#) requirements for solar access are provided in the R-Codes Volume 1, solar access guidelines have been included in these explanatory guidelines and may be taken into account in the consideration of applications according to the [design principles](#).

### Codifying climate-sensitive design

In terms of [residential development](#), the three main aims of climate-sensitive design are to reduce energy consumption, optimise on-site solar access and protect solar access for neighbouring properties.

However, it is difficult to translate these aims into development provisions. This is not because the issues are subjective but because conditions vary greatly from one situation to another, making it difficult to establish universally valid rules. To give an obvious example, a narrow east-west oriented [lot](#) on the south side of a [development site](#), especially where the terrain slopes to the south, is highly vulnerable to being overshadowed, even by a relatively low [building](#) set back from the common boundary. By contrast, where lots are oriented north-south, even tall buildings built up



Figure 65: Extract of Climate Zone Map BCA Figure A1.1 in Volume 1 or Figure 1.1.4 in Volume 2.

## 7 Design elements of the R-Codes Volume 1 – Building design

[Return to contents page](#)

### 7 Design elements of the R-Codes Volume 1 – Building design

General

Specific design elements

7.1 Visual privacy

7.2 Solar access for adjoining sites

7.3 Outbuildings

7.4 External fixtures

7.5 Utilities and facilities

#### General guidelines

to the common boundary have little potential for overshadowing. In other cases, the shadows cast may largely fall on blank [walls](#) or roofs.

[Site](#) location, orientation and topography must be taken into account by the proponent in the design of the [development](#).

Because it is impossible to adequately codify and enforce good design practice, the R-Codes Volume 1 deal with the issues in three ways:

- by setting out relevant factors for design of a development;
- by setting down conservative [deemed-to-comply](#) limits to overshadowing, which should be satisfactory for most developments, especially for [single houses](#) in low to medium-density range areas; and
- by encouraging proponents and [decision-makers](#) to use the [design principle](#) approach in difficult or complex cases.

#### Protecting solar access for neighbouring properties

Development should be designed so that it does not seriously affect solar access for neighbours. The R-Codes Volume 1 include maximum allowable percentages of overshadowing of:

- [adjoining properties](#) generally; and
- the north facing [major openings](#) to [habitable rooms](#) and roof mounted [solar collectors](#) of adjoining properties.

In most cases this means avoiding very tall walls close to southern boundaries, so that excessive shadows are not cast across the north-facing openings adjacent. In some cases, overshadowing by west or east-facing walls may also be important (R-Codes Volume 1 [figure 11a](#)).

As with overlooking, but even more so, the potential for a [building](#) to overshadow a neighbouring site, or be overshadowed itself, varies enormously from case to case. The variables are several and complex and include:

- the density of [development](#);
- the height of buildings, existing and proposed;
- the position of buildings, existing and proposed, in relation to boundaries;
- the orientation of the development site and its neighbours, that is, the relative position of the sun;
- the relevant dimensions and shape of the development site and of affected neighbouring sites; and
- the degree and orientation of slope of the land.

It is clear that the sites most vulnerable to overshadowing are narrow east-west orientated sites, on the south side of a development site, especially if they are also lower or on a south facing slope. In such cases, even a relatively low building may cast mid-winter shadow over a greater proportion of the site than allowed under deemed-to-comply provisions. In some instances, such a lot may abut two or more properties to the north, and would be subject to overshadowing by two or more properties. The deemed-to-comply provisions of the R-Codes Volume 1 therefore reduce the amount that some [lots](#) can

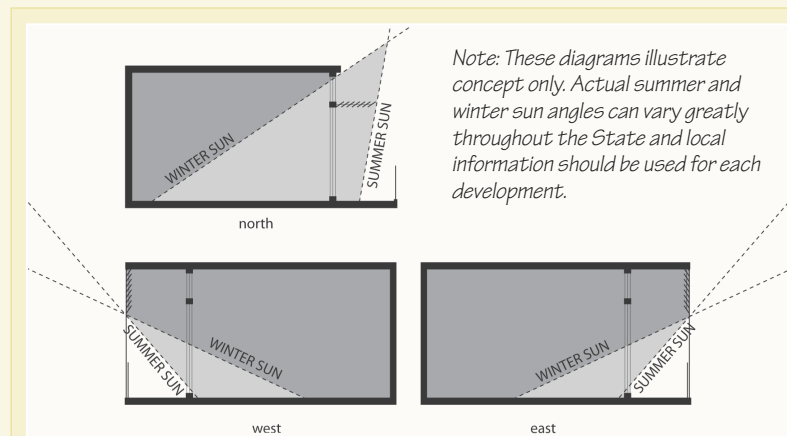

**Figure 66:** Orientating outdoor living areas and major openings to habitable rooms to the north maximises light penetration opportunities to reduce heating and cooling costs.



## 7 Design elements of the R-Codes Volume 1 – Building design

[Return to contents page](#)

### 7 Design elements of the R-Codes Volume 1 – Building design

General

Specific design elements

- 7.1 Visual privacy
- 7.2 Solar access for adjoining sites
- 7.3 Outbuildings
- 7.4 External fixtures
- 7.5 Utilities and facilities

#### General guidelines

overshadow proportionate to the property boundary they share (R-Codes Volume 1 [figure 11b](#)). It is possible, however, that some overshadowing is unavoidable. In these cases, careful consideration as to what is being overshadowed, rather than the extent of overshadowing, should be judged on merit and the [design principle](#) applied (refer to figure 67).

In other cases a shadow cast by a proposed [building](#) may exceed the allowable limits in theory, but in practice may simply be casting a shadow onto a boundary [wall](#) or roof or both, with minimal adverse effect.

A shadow may not exceed the limit but may fall over the only available [outdoor living area](#), or living room window of an adjoining [dwelling](#).

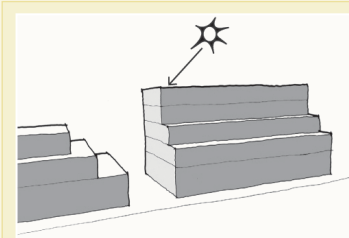

*Building does not allow for solar penetration to adjoining property to the south.*

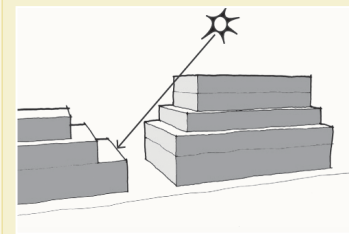

*Amenity of the adjoining property is not adversely affected by the design of the building, allowing solar access into the adjoining building.*

*Setting taller elements back from common boundaries provides a more appropriate scale minimising the impact of the new development on existing built form.*

**Figure 67:** By stepping the upper levels of a building back, adequate solar access to habitable rooms and open space on adjoining property is provided.

### Calculation of overshadowing

The assessment of the shadow cast by a building at midday 21 June is straightforward, and shown in [figure 11a](#) of the R-Codes Volume 1. The methodology for determining the shade cast can be found in the *Sunshine and Shade Australasia*, Phillips, R.O., Commonwealth Scientific and Industrial Research Organisation (Australia), Division of Building Construction and Engineering, Canberra, ACT 1992. Reference should be made to the specific tables in this document.

In general terms the shadow cast is calculated by:

- selecting the vertical sun angle from the following chart that lists the major urban centres from Albany to Wyndham; and
- transposing the length of shadow on to the [site](#) plan, taking care to correctly orientate the [building](#) and allow for the slope of the land (R-Codes Volume 1 figure 11a).

City/Town	Latitude (S)	Vertical sun angle
Albany	35	31
Perth	32	34
Kalgoorlie	31	35
Geraldton	28	38
Carnarvon	25	42
Port Hedland	20	47
Broome	18	49
Wyndham	15	52



[Return to contents page](#)

### 7 Design elements of the R-Codes Volume 1 – Building design

General

Specific design elements

7.1 Visual privacy

7.2 Solar access for adjoining sites

7.3 Outbuildings

7.4 External fixtures

7.5 Utilities and facilities

Part 5 only

### 7.2.1 Solar access for adjoining sites – Part 5 of the R-Codes Volume 1

([Clause 5.4.2 of R-Codes Volume 1](#))

#### Design for climate: energy conservation and comfortable living

The south of the State enjoys a climate suited to outdoor living and comfortable living indoors, throughout the year.

The important factors to take into account for the temperate south-west, and southern regions of the State, including the Perth metropolitan region, and also much of the State with hot dry climates (generally zones 4, 5 and 6 in [figure 65](#)) are as follows:

- The sun is further north in winter than in summer, and its angle is much lower. This means that a simple, properly calculated, north-facing roof overhang will allow the winter sun in and keep the summer sun out.
- [Dwellings](#) should be laid out so that at least one living area, preferably the one used most of the day, faces north or within 15 degrees of north. An [outdoor living area](#) is also best located on the north side of the dwelling.
- [Pergolas](#) with removable, adjustable, solar-orientated awnings or deciduous vegetation can be designed and planted to provide solar access for desired times in the winter, while excluding solar access for desired times in summer.
- The sun is most fierce in summer in the afternoon. At this time it comes from the west or west-south-west, so areas of glass facing in that direction should be avoided. Protect the dwelling with trees or vegetation (preferably deciduous, so as to allow in the sun in winter), pergolas or [verandahs](#).
- The morning sun comes more directly from the east in summer, but will generally have moved to the north and then west before the ambient temperature rises. Therefore, east-facing [walls](#) are not as critical as west-facing, but the use of glass should still be kept to a minimum, unless screened.
- The sun never hits the south face of a dwelling in winter: large areas of glass on the south will allow heat to escape in winter.

- Cooling breezes in summer come to the Swan coastal plain from the south-west; design should allow for letting these in while protecting windows from the sun, and avoiding crowding vegetation so close that they will hinder breezes.

All of these factors need to be verified for relevance to other regions. For example, sun angles vary significantly with latitude, and the time and direction of cooling breezes varies with proximity to the ocean and other factors. In the hot humid regions, thorough ventilation, and hence space around [buildings](#), and shade are more important than solar penetration in winter (refer to figures 68 - 70).

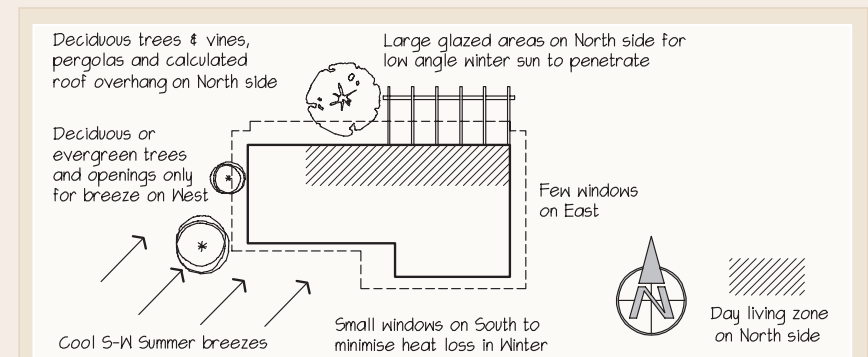

**Figure 68:** Some principles for the siting of a dwelling in the temperate zone.

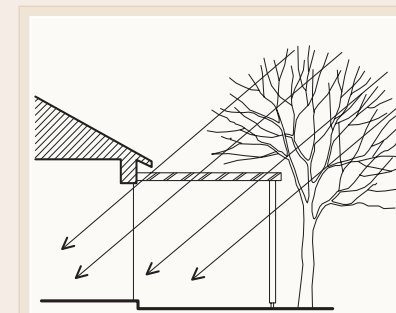

**Figure 69:** Solar pergola and deciduous trees.

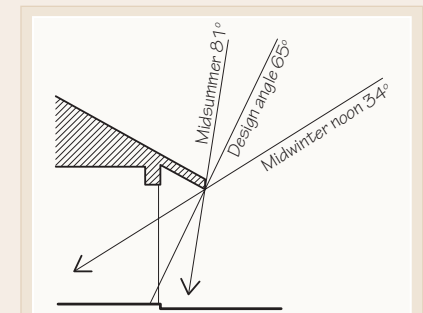

**Figure 70:** Calculated eaves overhang on north side, Perth.



[Return to contents page](#)

### 7 Design elements of the R-Codes Volume 1 – Building design

General

Specific design elements

- 7.1 Visual privacy
- 7.2 Solar access for adjoining sites
- 7.3 Outbuildings
- 7.4 External fixtures
- 7.5 Utilities and facilities

Part 5 only

#### Achieving solar access on site

The shape and orientation of [lots](#) sometimes makes it difficult to achieve optimum solar layout of a [development](#). This may also conflict with the principle of [dwellings](#) facing the [street](#) and often a compromise will have to be made.

It should be the practice of [decision-makers](#) to assist, where necessary, by making concessions in particular cases, especially by modifying side [setbacks](#) to allow solar access, provided that neighbours' privacy or solar access is not affected. These concessions may include [building](#) up to a side boundary.

In other cases, the only available private north facing [open space](#) may be within the street setback area. The R-Codes Volume 1 recognise this, for example, by modifying the provision for fencing in the street setback area to allow for private outdoor living space.

#### Reflective roofs

Reflective roofs are useful and effective in reducing the heat absorbed by a dwelling. However, very highly reflective roofs sometimes cause glare and discomfort to neighbours.

In some situations it may be desirable or necessary to use a material or finish, such as Colorbond, in a light but less reflective colour. Conversely, dark roofs increase absorption of heat and should be avoided.

#### Energy-efficient design

The [WAPC](#) has made provision for energy efficient [lot](#) design in Liveable Neighbourhoods. For guidance on the requirements of energy efficient [design principles](#) and minimum construction standards, reference should be made to the BCA.



[Return to contents page](#)

### 7 Design elements of the R-Codes Volume 1 – Building design

General

Specific design elements

- 7.1 Visual privacy
- 7.2 Solar access for adjoining sites
- 7.3 Outbuildings
- 7.4 External fixtures
- 7.5 Utilities and facilities

#### General guidelines

### 7.3 Outbuildings

#### [\(Clause 5.4.3 of the R-Codes Volume 1\)](#)

All [outbuildings](#) could, in theory, be regarded as [buildings](#) and made to comply with the same design guidelines as the main building or buildings. However, Australia has a long tradition of backyard sheds, workshops, [garages](#) and other similar buildings, including outside laundries and toilets, and these have always been regarded in a different light to the main buildings they serve. The tradition is changing because contemporary living standards have led to the demise of the outside laundry and toilet, in part because the spacious quarter acre block has since given way to smaller [lots](#), and also because urban lifestyles have changed.

Nevertheless, there is a case for relaxed standards for some outbuildings. The criteria should be that they do not detract from the essential functions of [private open space](#), the visual amenity of neighbours or the streetscape. This means that any outbuilding that is to be exempt from the residential or [dwelling](#) standards should be:

- relatively small in area;
- relatively low in height;
- sited so as to preserve the use and amenity of [open space](#);
- set back sufficiently from boundaries;
- confined to [single houses](#) and [grouped dwellings](#); and
- excluded from [street setback areas](#).

Other common private garden or backyard constructions such as [pergolas](#), cubby houses and play fixtures, and dog kennels have not been included in the definition of building and are exempted from planning control, although some [decision-makers](#) do have policies to control certain backyard constructions (for example, cubby houses).

While outbuildings of less than 60m<sup>2</sup> in area (or 10 per cent of the site, whichever is the lesser) and no more than 2.4m in [wall height](#) are [deemed-to-comply](#), they are still required to be sited in accordance with the [setback](#) requirements of [clause 5.1.3](#) of the R-Codes Volume 1 and comply with open space requirements in [table 1](#) of the R-Codes Volume 1.



[Return to contents page](#)

### 7 Design elements of the R-Codes Volume 1 – Building design

General

Specific design elements

7.1 Visual privacy

7.2 Solar access for adjoining sites

7.3 Outbuildings

7.4 External fixtures

7.5 Utilities and facilities

General guidelines

### 7.4 External fixtures

[\(Clause 5.4.4 R-Codes Volume 1\)](#)

[External fixtures](#) include items attached to or emerging from [buildings](#), including:

- [solar collectors](#)
- television, radio, other antennae and satellite dishes
- plumbing vents and pipes
- external hot water heaters
- air conditioners
- rain water tanks.

The BCA encourages water and energy efficiency of all housing in Australia. It is therefore an objective of the R-Codes Volume 1 to assist in the widespread adoption of technologies that may improve the sustainability of urban housing.

The location of solar collectors determines their efficiency, hence their positioning needs to be site-specific and is therefore permitted as of right. Television antennae of the standard type, essential plumbing vents above the roof line and external roof-water down pipes are accepted as minor and [deemed-to-comply](#).

Any other external fixtures, which in the opinion of the [decision-maker](#), may have greater potential to detract from amenity and streetscape, should be subject to planning control, and may be the subject of [local planning policies](#) (refer to figure 75).



*Rooftop plant and infrastructure dominates appearance of the building.*

**Figure 75:** External fixtures can be unsightly and detract from the streetscape.

General guidelines

### 7.5 Utilities and facilities

[\(Clause 5.4.4 of the R-Codes Volume 1\)](#)

For the purposes of the R-Codes Volume 1, utilities and facilities fall into two categories:

- essential facilities, such as clothes drying, general storage and rubbish bin storage; and
- optional facilities, such as a tennis court, swimming pool, gymnasium, gazebo, security fencing and gates, or below ground car parking.

Adequate provision for the above essential facilities is required in all [grouped](#) and [multiple dwelling developments](#) because they are important to the functionality of these developments.



[Return to contents page](#)

### 8 Design element for Part 5 of the R-Codes Volume 1 – Special purpose dwellings

Specific design elements

8.1 Ancillary dwellings

8.2 Aged or dependent persons' dwellings

8.3 Single bedroom dwellings

### Specific design elements

#### [\(Clause 5.5 of the R-Codes Volume 1\)](#)

Part 5 of the R-Codes Volume 1 encompass three types of special purpose dwellings:

- 8.1 ancillary dwellings;
- 8.2 aged or dependent persons' dwellings; and
- 8.3 single bedroom dwellings.

These dwelling types may require discretionary approval under the relevant [scheme](#).

The provisions for these sections are only applicable to Part 5 of the R-Codes Volume 1 and therefore only apply to all [single house\(s\)](#) and all [grouped dwellings](#) and [multiple dwellings](#) in areas coded less than R40. [Aged](#) or [dependent persons'](#) dwellings and [single bedroom dwellings](#) may take the form of either grouped or multiple dwellings and where proposed as multiple dwelling types in areas coded R40 or higher, the R-Codes Volume 2 apply.

Part 5 only

### 8.1 Ancillary dwellings

#### [\(Clause 5.5.1 of the R-Codes Volume 1\)](#)

To encourage diversity in accommodation types, and to provide a means for residents to live in proximity but with autonomy, the R-Codes Volume 1 provide for [ancillary dwellings](#), sometimes referred to as granny flats. This is essentially an independent dwelling, which may or may not be physically attached, on the same [lot](#) (with a minimum lot size of 450m<sup>2</sup>) as a [single house](#). Such dwellings would include, for example, 'Fonzie Flats' (studios located above [garages](#)); separate rear studios; and self-contained quarters within a single house; for example, a second storey or separate ground floor wing that may have a shared lobby/entry or separate external access.

There is no longer a restriction regarding occupancy of ancillary dwellings by family members of the primary dwelling.

While an ancillary dwelling is a self-contained dwelling, the extent of facilities provided would be at the discretion of the landowner. It is generally accepted that a separate kitchen and bathroom would be provided. The provision of a laundry would not be essential from a planning point of view. Meeting BCA requirements may, however, require the provision of laundry facilities.

Services also may be shared; the rental of an ancillary accommodation would function in a similar manner as a boarder; however, utility providers may have specific requirements for the separate provision of services, for example, separate water, power, sewer, gas and telecommunications.

Subdivision (for example, into [strata lots](#), built-strata lots or [green-title lots](#)) is not permissible as specified by the definition of [ancillary dwellings](#) under the R-Codes Volume 1. The single house (primary [dwelling](#)) and ancillary dwelling are considered two dwellings on one lot. Subdivision could only occur subject to meeting minimum lot size requirements (and other R-Code Volume 1 provisions) of the density code of the [site](#) under a [scheme](#) as grouped dwellings or two single houses.



[Return to contents page](#)

### 8 Design element for Part 5 of the R-Codes Volume 1 – Special purpose dwellings

Specific design elements

- 8.1 Ancillary dwellings
- 8.2 Aged or dependent persons' dwellings
- 8.3 Single bedroom dwellings

Part 5 only

[Ancillary dwellings](#) are limited in size to 70m<sup>2</sup>. [Development](#) is required to meet requirements set out in Part 5 – Design Elements for all [single house\(s\)](#); all [grouped dwellings](#); and, [multiple dwellings](#) in areas with a coding of less than R30, as they relate to single houses (for example, [setbacks](#)) or as specifically provided for (for example, parking) with the exception of:

- 5.1.1 site area;
- 5.2.3 street surveillance (except where located on a lot with secondary street or right of way access); and
- 5.3.1 outdoor living areas.

### 8.2 Aged or dependent persons' dwellings

[\(Clause 5.5.2 the R-Codes Volume 1\)](#)

The intention of this provision is to encourage the development of small-scale specialised housing in local communities, as an alternative to larger scale, relatively segregated retirement village/nursing home-type complexes. Because [aged](#) or [dependent persons' dwellings](#) are generally smaller than conventional dwellings, and the occupants do not usually have a high car ownership ratio, the R-Codes Volume 1 under [deemed-to-comply clause 5.1.1 C1.4i](#) of the R-Codes Volume 1 allow the reduction of the [site area](#) by one-third of that provided for by the R-Code applying to the [site](#) and [clause 5.3.3](#) provides for reduced car parking standards.

To prevent these concessions from being abused, for example as a back door way of increasing density for standard housing without re-coding an area, the concessions are subject to four constraints:

- there is a limit on the size of such dwellings;
- they must be purpose-designed;
- there is a minimum of five dwellings in a single development; and
- they are subject to a legal agreement to restrict occupancy.

The development of aged or dependent persons' dwellings is otherwise required to comply with all other R-Code Volume 1 provisions as relevant. Only clauses pertaining to the type (such as grouped dwellings or multiple dwellings) of development proposed are applicable.

In relation to the minimum number of dwellings in a single development, the [decision-maker](#) may make [local planning policies](#) that reduce the minimum number where it determines appropriate to facilitate additional aged or dependent persons' dwellings.

The design of aged or dependent persons' dwellings must incorporate, or at the very least, allow for future incorporation of features that are required to serve the special needs of aged or dependent persons, such as ramps and wider doorways and passageways to accommodate wheelchairs and handrails in bathrooms and toilets.



[Return to contents page](#)

### 8 Design element for Part 5 of the R-Codes Volume 1 – Special purpose dwellings

Specific design elements

- 8.1 Ancillary dwellings
- 8.2 Aged or dependent persons' dwellings
- 8.3 Single bedroom dwellings

#### Part 5 only

It is important that [aged](#) or [dependent persons' dwellings](#) are designed to allow for ageing in place, whereby dwellings cater for an individual to remain in their chosen place of residence even though their physical and sensory abilities may change in the future. Certain minimum standards, as set out in appropriate Australian Standards must be part of the original construction, or can be introduced (retrofitted) with ease in the future. In particular, this would include designs with minimal use of varying floor levels and stairs, adequate passageways and door widths, roofed car parking spaces, accessible utilities and slip resistant floors for kitchens, laundries, bathrooms and toilets as described in AS 4299:1995, Adaptable Housing. This would result in such dwellings being more flexible to accommodate the changing needs of older people.

In addition, it is necessary to stipulate an age threshold of 55 years in the case of aged persons' dwellings, however, there is no constraint on the dwelling type. The concessions apply equally whether they involve [single houses](#) or [grouped](#) or [multiple dwellings](#).

It is also not necessary that the whole of any particular [development](#) comprise [special purpose dwellings](#), or even consist of the same type of dwelling. It is possible, for a development to comprise a mix of dwelling types to cater for different ageing in place needs. An integrated facility may comprise a variety of dwelling types incorporating aged persons' dwellings for low-care/independent residents, serviced apartments for medium-care residents and nursing home type accommodation for high-care residents.

### 8.3 Single bedroom dwellings

[\(Clause 5.5.3 the R-Codes Volume 1\)](#)

One or two-person households now make up over half of all households in Western Australia. [Single bedroom dwellings](#) provide an important source of alternative and affordable housing for singles, students and couples. To encourage their development, and because dwellings of this nature result in a low population density per dwelling unit, they do not generate the same demands for car parking as two or three bedroom dwellings, and result in less [building](#) bulk. The R-Codes Volume 1 allow the same [site area](#) concessions as for aged or dependent persons' dwellings ([clause 5.1.1 C1.4i](#) of the R-Codes Volume 1), however, there are no constraints on the age of occupants and there is no requirement for special facilities to be provided.

To prevent these concessions from being abused, and to ensure that affordable housing options are provided through these concessions, it is important to ensure that floor area and site plans clearly propose a dwelling that would only support single or couple living arrangements in accordance with the definition of single bedroom dwelling under the R-Codes Volume 1.

The development of single bedroom dwellings is required to comply with all R-Code Volume 1 provisions as relevant, except as specifically exempted (for example, site area concession of [clause 5.1.1](#) of the R-Codes Volume 1). Only clauses relevant to the type of development proposed would be relevant, such as provisions related to either grouped dwellings or multiple dwellings, depending on the form of development proposed.



## 9 Local planning framework

[Return to contents page](#)

### 9 Local planning framework

General

9.1 Scope of local planning policies, structure plans and local development plans

9.2 Local planning policy proforma

9.3 The R-Codes and schemes

### General

[\(Part 7 the R-Codes Volume 1\)](#)

The adoption of [local planning policies](#) and [local development plans](#) to supplement [schemes](#) and the R-Codes by [decision-makers](#) has grown dramatically in number, sophistication and importance in recent years. This has led to some confusion and inconsistency, and often added delays and costs to the construction of [dwellings](#). In some cases the legitimacy of such policies is in doubt, either because of the lack of an appropriate head of power, or inconsistency with the provisions of the R-Codes.

The R-Codes aim to lessen the need for the use of local planning policies and local development plans which incorporate generic provisions, such as those designed to protect privacy and to address streetscape, by incorporating these aspects in the R-Codes.

The R-Codes recognise that local differences of character must be accommodated and so the [design principles](#) create a framework for these to be purposefully addressed by housing design and to enable certain R-Code provisions to be varied by the adoption of local planning policies, [structure plans](#) and [local development plans](#), properly advertised and adopted as required by a scheme.

Only those local planning policies, [structure plans](#) and [local development plans](#) that are properly made in terms of scheme provisions, and are consistent with the R-Codes, have effect under the R-Codes.

Where the decision-maker adopts a local planning policy, [structure plan](#) or local development plan that, in its opinion, may affect the interests of the [WAPC](#), then the decision-maker is to forward a copy to the WAPC for consideration and approval.

### 9.1 Scope of local planning policies, structure plans and local development plans

[\(Clause 7.3 the R-Codes Volume 1\)](#)

The R-Codes Volume 1 restrict the preparation of [local planning policies](#), local structure plans and [local development plans](#) that seek to vary the R-Codes Volume 1 only to the following design elements:

#### Context

street setbacks [\(clause 5.1.2\)](#)  
lot boundary walls [\(clause 5.1.3 C3.2-3.3\)](#)  
building height [\(clause 5.1.6\)](#)

#### Streetscape

setback of garages and carports [\(clause 5.2.1\)](#)  
garage width [\(clause 5.2.2\)](#)

#### street surveillance

street walls and fences [\(clause 5.2.3\)](#)  
sightlines [\(clause 5.2.4\)](#)  
appearance of retained building [\(clause 5.2.5\)](#)  
[\(clause 5.2.6\)](#)

#### Site planning and design

site works [\(clause 5.3.7\)](#)

#### Building design

external fixtures [\(clause 5.4.4\)](#)

#### Special purpose dwellings

Aged and dependent persons' dwelling(s) [\(clause 5.5.2 C2.1ii\)](#)

A more detailed outline of those aspects of the design elements which may be varied is provided as follows.



## 9 Local planning framework

[Return to contents page](#)

### 9 Local planning framework

General

9.1 Scope of local planning policies, structure plans and local development plans

9.2 Local planning policy proforma

9.3 The R-Codes and schemes

### 9.1.1 Context

[Local planning policies](#) may be prepared for [street setbacks](#) ([clause 5.1.2](#) of the R-Codes Volume 1) that provide amended requirements for:

- primary and [secondary street](#) setbacks
- controls relating to [development](#) in the front [setback](#)
- averaging of front setbacks.

Local planning policies may be prepared for [lot boundary](#) setbacks ([clause 5.1.3 C3.2–3.3](#) of the R-Codes Volume 1) that provide amended requirements for the:

- dimensions of lot boundary [walls](#)
- need for lot boundary walls to be considered against the design principle measures following neighbour consultation.

Local planning policies may be prepared for [building height](#) ([clause 5.1.6](#) of the R-Codes Volume 1) that apply:

- category A provisions of [Table 3](#) to the whole district, or individual precincts;
- category C provisions of [Table 3](#) to the whole district or individual precincts;
- category A standards of [Table 3](#) to specific development situations such as rear battleaxe developments or [aged](#) or [dependent persons' dwellings](#); and
- alternative approaches to controlling the height of buildings.

### 9.1.2 Streetscape

Local planning policies may be prepared for streetscapes that provide amended requirements for:

- setback of garages and carports ([clause 5.2.1](#) of the R-Codes Volume 1)
- garage width ([clause 5.2.2](#) of the R-Codes Volume 1)
- street surveillance ([clause 5.2.3](#) of the R-Codes Volume 1)
- street walls and fences ([clause 5.2.4](#) of the R-Codes Volume 1)
- sight lines ([clause 5.2.5](#) of the R-Codes Volume 1)
- appearance of retained dwelling ([clause 5.2.6](#) of the R-Codes Volume 1)

### 9.1.3 Site planning and design

Local planning policies may be prepared that vary requirements for filling behind a [street setback](#) line and within 1m of a common boundary greater than 0.5m above the [natural ground level](#) at the boundary ([clause 5.3.7](#) of the R-Codes Volume 1).

### 9.1.4 Building design

External fixtures attached to, or emerging from, [buildings](#) that may have potential to detract from the amenity and streetscape may be the subject of local planning policies to the extent that these do not alter the [deemed-to-comply](#) provisions. These are non-standard type television, radio, other antennae and satellite dishes, external hot water heaters, air conditioners, and rain water tanks. However, the location of [solar collectors](#) determines their efficiency hence their positioning needs to be site-specific and is therefore permitted as of right. All other external fixtures such as television antennae of the standard type, essential plumbing vents above the roof line, and external roof-water down pipes are considered as minor and are not subject to local planning policies ([clause 5.4.4](#) of the R-Codes Volume 1).

### 9.1.5 Special purpose dwellings

The deemed-to-comply provisions for aged or dependent person's dwellings require a minimum of five dwellings in a single development ([clause 5.5.2 C2.1ii](#) of the R-Codes Volume 1). In view of the ageing population and changing health needs of the community, local planning policies may be made to allow a lower minimum number of dwellings per development.





## 9 Local planning framework

[Return to contents page](#)

### 9 Local planning framework

General

- 9.1 Scope of local planning policies, structure plans and local development plans
- 9.2 Local planning policy proforma
- 9.3 The R-Codes and schemes

### 9.1.6 Regional exceptions

The R-Codes are designed to apply throughout Western Australia. It is recognised that a [decision-maker](#) may wish to prepare a [local planning policy](#) to vary a particular aspect of any one of the design elements in recognition of a regional circumstance. Regional circumstances may present themselves in the form of climatic extremes, topographical variations or physical landform and geomorphologic differences. Decision-makers seeking to vary aspects of the design elements as a regional exception should, prior to the adoption of such a local planning policy, provide full justification to the [WAPC](#) and seek its approval to proceed as required under [clause 7.3.2](#) of the R-Codes Volume 1.

### 9.2 Local planning policy proforma

Where local planning policies are prepared the format should be in accordance with the local planning policy proforma in Appendix 2.

[Structure plans](#) and [local development plans](#) may be prepared and adopted for particular locations that require individual development standards for the protection and/or creation of particular character and with respect to a particular [site](#) or sites.

Where local development plans are prepared the format should be in accordance with the local development plan in Appendix 3.

Amendments or replacements to R-Codes Volume 1 [deemed-to-comply](#) provisions are to be consistent with the relevant [design principle](#).

### 9.3 The R-Codes and schemes

The R-Codes apply to all [residential development](#) throughout Western Australia and provide a consistent set of design standards for residential development. The R-Codes refer to the State planning objectives and these are to be taken into account by the [decision-maker](#) in assessing a residential development proposal.

The R-Codes provide for an appropriate choice and distribution of housing types and densities to meet the needs of the community as a whole, appropriate to local conditions and amenity.

The design principles of the R-Codes should be considered by local planning or housing strategies, taking into account local context and planning issues and reflected in its objectives. Both State and local objectives may then be referenced in the assessment of a residential development proposal.

It is important for [schemes](#) and local planning or housing strategies to provide the local context within which design and [development](#) proposals can be considered, and to ensure that they identify the best applicable R-Coding and provisions, after properly considering and addressing:

- [lot](#) size, shape and variation from the average lot area within each zone;
- capacity of infrastructure to service housing at the density proposed;
- community values, both protecting what has value from the past, and new opportunities for the future;
- access, transport and proximity to movement networks;



## 9 Local planning framework

[Return to contents page](#)

### 9 Local planning framework

General

9.1 Scope of local planning policies, structure plans and local development plans

9.2 Local planning policy proforma

9.3 The R-Codes and schemes

- access to social infrastructure such as open space, schools, hospitals, sporting and community facilities;
- mixture of housing types, density and social diversity; and
- proximity to economic activity such as employment centres, ports, and [activity centres](#).

Although the R-Coding will be designated on the [scheme](#) map, the local planning or housing strategy will explain the designation of the particular R-Coding for particular local areas in the scheme.

Where there are individual needs, the R-Codes may need to be supplemented by a [local planning policy](#), [local development plan](#) or a special control area which may be implemented through schemes.

### 9.3.1 Local planning strategies

A [local planning strategy](#) provides the rationale and vision that underlies the regulatory provisions of the scheme, including the specific R-Code designations of the scheme.

The strategy may incorporate a local housing strategy. The issues that are relevant in the housing component of a local planning strategy, and the selection of the relevant R-Code for the various parts of the municipality, include:

- recognition of the regional demand for a range of densities/[development](#) intensity and [dwelling](#) types;
- socioeconomic and demographic profiles, both existing and likely in the future;
- existing lot sizes;

- current and future infrastructure, including the road network, sewerage, water supply, power, significant employment centres, social and recreational facilities and public transport facilities;
- age and condition of existing housing stock;
- existence of [sites](#) suitable for new housing development, redevelopment or infill;
- trends and market demand for various forms of housing;
- heritage and streetscape values;
- existing and desired character of particular precincts; and
- land values and the effect of proposed density changes on them.

This list is not exhaustive or ranked in order of importance. The issues are useful for analysing the appropriateness of existing or proposed R-Codings.

### 9.3.2 Local planning schemes

The R-Codes are implemented through local planning schemes and applied to zones that allow residential land use. There is flexibility in their application by providing a choice of R-Codings to facilitate a range of [residential development](#) types and densities (ranging from traditional low-density suburban development to higher-density [activity centres](#)).

The R-Codes aim to provide certainty for assessing development proposals and to increase flexibility to allow the consideration of good design and innovation, while meeting the objectives of the R-Codes and any relevant local planning objectives.

### 9.3.3 Density control

The application of the minimum [site area](#) requirements of the R-Codes R-Codes Volume 1 will assist in the achievement of housing density targets determined during the strategic planning process. Before making a decision as to the R-Code to be applied to a particular area, the [decision-maker](#) should first examine the density targets and housing character specified in its local planning or housing strategy for each precinct or locality. It will then be necessary to identify which R-Code is most likely to promote the density targets and reflect the desired housing character.

For existing urban areas the process of allocating an R-Code in a scheme requires careful assessment of the relationship between the [lot](#) sizes prevailing in a locality, current trends in demand for particular types of housing, and any adopted strategic planning policy relevant to residential density/development intensity.

### 9.3.4 Changes in housing density

Sometimes planning and design problems arise from a change in the R-Code designation between different areas or neighbourhoods. Issues of [setback](#), visual dominance, overlooking and privacy are often evident. Due consideration needs to be taken when identifying where an R-Code density will change.

Local planning provisions need to give due consideration to neighbourhood design. A scheme will need to carefully consider such factors when delineating R-Codes and changes from one R-Code density to another. [Development sites](#) should respect adjoining properties where land use or



## 9 Local planning framework

[Return to contents page](#)

### 9 Local planning framework

General

- 9.1 Scope of local planning policies, structure plans and local development plans
- 9.2 Local planning policy proforma
- 9.3 The R-Codes and schemes

zoning differs, particularly where two residential [lots](#) with different R-Codings adjoin, or where a commercial zone (mixed use) adjoins a residential zone.

An R-Code boundary along the rear of a property boundary, aligned along a rear laneway or [right-of-way](#), may in some cases be preferable. However, it is often the rear of existing housing [developments](#) (such as bedrooms, private spaces and courtyards) which generally has a higher need for privacy, daylight and overshadowing (refer to figure 79).

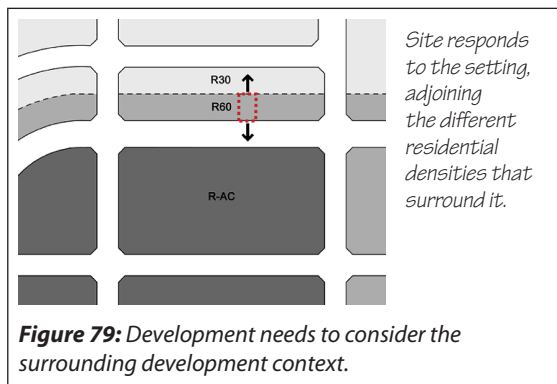

### 9.3.5 Restricted coding

The assignment of a particular R-Code to a given area will normally mean that all the varying housing types (such as single, grouped and multiple) included in that R-Code under [table 1](#) will be permissible, or at the very least, discretionary within that area.

There may be areas where the [decision-maker](#) may wish to secure a given density but without permitting the full range of housing types available under the relevant density code.

For example, consider an area which contains lots of 1,000m<sup>2</sup> occupied by [single houses](#). The decision-maker may decide that it wishes to allow for some increase in residential density, but retain the single house appearance and character of the area. It is prepared to see single houses or [grouped dwellings](#) on small lots, on a limited basis, where they have [frontage](#) to a public [street](#).

To achieve this:

- the area is coded R25 on the [scheme](#) map; and
- a clause is inserted in the scheme text which reads: “Within the area bounded by (name the streets or otherwise clearly define the area) that is coded R25, a single house or grouped dwelling may not be constructed unless the frontage is at least 10m to a public street”.

### 9.3.6 Expanded or dual coding

The opposite of restricted coding is an expanded coding where the decision-maker may wish to permit specific [dwelling](#) types not included in the selected code under [table 1](#) of the R-Codes Volume 1.

For example, in the case of expanded coding the decision-maker determines that a particular part of the residential zone should comprise primarily single houses on lots with a minimum lot area of 700m<sup>2</sup> but it is also prepared to consider, on its merits, applications for the construction of a pair of grouped dwellings, notwithstanding that grouped dwellings are prohibited in the zone as a whole, provided a lot has a minimum area of 1,000m<sup>2</sup>.

To achieve this:

- the area is coded R12.5 on the scheme map; and
- a clause is inserted in the scheme text which reads: “Within the area bounded by (name the streets or otherwise clearly define the area) coded R12.5, the decision-maker may permit the construction of not more than two grouped dwellings in accordance with the standards of the R20 code on any lot of not less than 1000m<sup>2</sup>”.

Examples of dual coding might include:

- (i) an area undergoing change and being redeveloped by the replacement of single houses on large [lots](#) by grouped dwellings at a higher density; or
- (ii) an area which has servicing constraints that is, reticulated sewerage and requires coordinated development with staged upgrading of servicing infrastructure.

Some of the older housing stock may be structurally sound and of a particular heritage or character that the [decision-maker](#) wishes to preserve. Although the existing lots are large for [single houses](#) (for example, 1,000m<sup>2</sup>), there would be positive planning advantages if two or more lots were amalgamated for redevelopment. The decision-maker determines that the R20 density code is generally appropriate but it would be prepared to accept the R30 code if certain criteria were met.

To achieve this:

- the area is coded R20/30 on the [scheme](#) map; and
- a clause is inserted in the scheme text which reads: ‘Within the area coded R20/30, development to the density and standards of the R30 code shall be permitted only if the development: a) involves not



## 9 Local planning framework

[Return to contents page](#)

### 9 Local planning framework

General

- 9.1 Scope of local planning policies, structure plans and local development plans
- 9.2 Local planning policy proforma
- 9.3 The R-Codes and schemes

*less than four nor more than six grouped dwellings or single houses; b) retains any existing house(s) that the decision-maker considers worthy of retention; and c) is consistent with the requirements of the scheme and any local planning policy”.*

### 9.3.7 Housing in non-residential zones

Most schemes provide for [residential development](#) to be possible in one or more non-residential zones, or zones which are not exclusively residential in nature.

Depending on the type of housing that is desired or acceptable, the [decision-maker](#) should designate the appropriate R-Code to apply within that zone or part of the zone, just as for the residential zone or zones. Where residential use is permitted in a zone but no specific R-Code is allocated, the R-AC3 code can be used as an indicative guide to assist in the absence of any other provision in the local planning framework.

### 9.3.8 Short-term accommodation

Whether or not the provisions of the R-Codes apply to the [development](#) of short-term accommodation (including serviced apartments), will be determined by the way in which the scheme deals with this type of land use.

Short-term accommodation may be proposed where a density coding applies but should be assessed under the R-Codes based on the form of development proposed.

Short-term accommodation which is proposed where no density coding applies must be assessed under the provisions of the scheme and the relevant design elements of the R-Codes used to guide and

inform the decision-making process, particularly, where the short-term accommodation is not serviced or attached to a hotel/motel (such as self-contained accommodation with integral cooking and laundry facilities for each [dwelling](#) unit.)

### 9.3.9 Residential buildings

Where it is proposed to develop a residential building as defined by the R-Codes, the extent to which the provisions of the R-Codes should be applied to the development of the [building](#) will be determined by the scheme and relevant provisions under the *Health Act 1911*, relating to residential buildings or lodging houses.

A residential building may be proposed where no density coding applies and should be assessed under the provisions of the scheme. In this case the relevant provisions of the R-Codes could be used to guide and inform the decision-making process.

### 9.3.10 Heritage matters

Heritage and character are issues addressed in schemes and local planning or housing strategies. The R-Codes therefore make no specific provisions related to heritage places and areas. Provision is made in clause 7.2 of the Model Scheme Text for the decision-maker to adopt a [local planning policy](#) for each heritage area, including objectives and guidelines for the conservation of heritage for that area. Clause 7.5 of the Model Scheme Text allows the decision-maker to vary any [site](#) or development requirement specified in the scheme or the R-Codes, where desirable, to enhance or preserve heritage values in a heritage area.

### 9.3.11 Residential precincts or localities

Precinct or locality-based planning recognises key housing differences, for example, in density, type and style of housing, landscaping and streetscape. It is often these parameters which contribute to a sense of place and create neighbourhoods. This is a big contributor to the quality of life and experience offered in many residential areas.

Planning by precincts is particularly relevant in established residential areas, places where redevelopment or infill development is taking place or where there is a mix of land uses and activity which present valued living experiences for residents.

In such cases, precinct or locality-based planning provides the best basis on which to allocate R-Code density, as well as identifying local character differences and responding to these with focused objectives.

Greenfield housing [development sites](#) on the peri-urban fringe and large-scale urban infill sites (for example, former industrial sites) are more suited to comprehensive structure planning through Liveable Neighbourhoods and/or [local development plans](#).

Some of the criteria that may be used in defining residential precincts include:

- well-defined areas with common existing and desired future characteristics;
- perception of precinct as an entity;
- broader than individual [streets](#), but smaller than suburbs;
- recognisable similarities or patterns in terms of land use, age and period of development,



[Return to contents page](#)

## 9 Local planning framework

General

9.1 Scope of local planning policies, structure plans and local development plans

9.2 Local planning policy proforma

9.3 The R-Codes and schemes

## 9 Local planning framework

subdivision pattern and lot sizes, and type, scale and style of housing;

- well-defined edges, defined by clear transition of use or character, busy streets, natural features such as a major park; or
- different land use and activities, divorced from surrounding areas of different density or character.

### 9.3.12 Special control areas

In localities or precincts of distinctive character it may be appropriate for the [decision-maker](#) to designate a special control area by amendment to the [scheme](#). Special control area provisions might typically deal with issues that aim to protect the special character of an area or to promote a particular development theme in order to establish and reinforce a sense of place. This may involve controls on the demolition of existing [buildings](#), particular design or siting requirements or controls in relation to the materials of construction. Other matters may include seeking control of [street setbacks](#), [building heights](#), roof pitches, street fencing and external appearance.



## Appendices

[Return to contents page](#)

### Appendices

Appendix 1:  
R-Codes Volume 1  
approval application and  
determination forms

Appendix 2:  
Local Planning Policy  
prepared via State Planning  
Policy 7.3 Residential Design  
Codes Volume 1

Appendix 3:  
Local development plan  
proforma

## Appendix 1: R-Codes Volume 1 approval application and determination forms

### Application for Residential Design Codes Volume 1 Approval single house and outbuildings

To: City/Town/Shire/other of:

**Note:** This is not an application for planning approval.

Application for single house and outbuilding approval is to be made on this form

if

an application for planning approval is not required under the local planning scheme

and

the proposed development involves one of the following:

- the judgement of merit by the decision-maker under the Residential Design Codes
- the judgement of merit by the decision-maker under a local planning policy made in accordance with the scheme.

If you are in doubt about whether application should be made on this form, please consult the decision-maker's planning or building officers.

#### Owner details:

Name:

Address:  Postcode:

Signature:  Date:

Signature:  Date:

All owners must sign this form or an attachment if there is not sufficient space. State your position where signing on behalf of a company. This application will not proceed otherwise.

#### Applicant details:

Name:

Address:

Contact person:  Phone:  Fax:

Email:  Signature:  Date:

#### Property details:

Lot no:  House/street no:

Street name:

Suburb:

Location no:  Diagram/plan no:  Certificate of title no:  Folio:

Nearest street intersection:

Title encumbrances (eg easements, restrictive covenants):

Approximate cost of proposed development:

Please fill in the details on the reverse

#### Details of proposal subject to judgement of merit

1. Please identify which specific design principle(s), from Part 5 of the Residential Design Codes Volume 1, the proposal applies (which will require judgement of merit).
2. Please provide full reasons in support of the application of each design principle.
3. Attach further information in support if needed and as required by Part 3 of the Residential Design Codes Volume 1.

#### Office use only

Accepting officer's initials:  Date received:

Council reference no:



## Appendices

[Return to contents page](#)

### Appendices

Appendix 1:  
R-Codes Volume 1  
approval application and  
determination forms

Appendix 2:  
Local Planning Policy  
prepared via State Planning  
Policy 7.3 Residential Design  
Codes Volume 1

Appendix 3:  
Local development plan  
proforma

### Residential Design Codes Notice of approval/refusal to application for Residential Design Codes approval

Proposal:

Location:

Name of owner of land on which the development is proposed:

Surname/company name:

Other name(s):

Address:

Approval to commence development in  
accordance with the application for

Residential Design Codes approval dated:

and plans dated:

is:  Approved

Approved subject to the following conditions

Refused for the following reasons

Conditions/reasons for refusal:

**Note:** Should the applicant be aggrieved by this decision, a right of review may exist under the provisions of the *Planning and Development Act 2005*.

This approval is valid for a period of:

If development is not commenced within this period a fresh approval must be obtained before commencing or continuing the development.

.....  
Chief Executive Officer

.....  
Date



## Appendices

[Return to contents page](#)

### Appendices

Appendix 1:  
R-Codes Volume 1  
approval application and  
determination forms

Appendix 2:  
Local Planning Policy  
prepared via State Planning  
Policy 7.3 Residential Design  
Codes Volume 1

Appendix 3:  
Local development plan  
proforma

## Appendix 2: Local Planning Policy prepared via State Planning Policy 7.3 – Residential Design Codes Volume 1

### Date Local Planning Policy Adopted by [*decision-maker*]:

#### 1.0 Policy objectives

- To specify local provisions which supplement the deemed-to-comply provisions of State Planning Policy 7.3 Residential Design Codes Volume 1 for residential development in the [policy area].
- To provide local housing objectives to guide judgements about the merits of proposals for residential developments with respect to local circumstances.

#### 2.0 Background

State Planning Policy 7.3 Residential Design Codes Volume 1 (the R-Codes Volume 1) includes provisions for decision-makers to prepare local planning policies to alter certain development standards of the R-Codes Volume 1 where a specific local need arises. The R-Codes Volume 1 also acknowledge that applications with proposals which do not satisfy the deemed-to-comply provisions of the R-Codes Volume 1 may need to rely more specifically on local housing requirements and design objectives.

This policy provides local housing objectives and varies relevant deemed-to-comply provisions of the R-Codes Volume 1 to assist in their implementation.

This policy should be read in conjunction with the R-Codes Volume 1.

#### 3.0 Application

This policy applies to all residential development in the [area covered by policy] and shall be considered by applications for planning approval under the [decision-maker's operative planning scheme] and approval under the R-Codes Volume 1.

The [decision-maker] will also apply this policy when preparing and determining structure plans and local development plans and will have regard to this policy when making recommendations to the Western Australian Planning Commission on subdivision of land for residential development, to ensure the lots created can be developed in accordance with this policy.

#### 4.0 Legal status

##### (a) Relationship to [operative planning scheme]

This policy is a planning policy prepared, advertised and adopted pursuant to [relevant clause] of [operative planning scheme]. The policy augments and is to be read in conjunction with the provisions of [operative planning scheme] relating to development.

If there is a conflict between this local planning policy and the Scheme, then the Scheme shall prevail.

##### (b) Relationship to other state planning/development control policies.

This policy has due regard to, and should be read in conjunction with state planning policies. Of particular relevance to this policy are:

- i) State Planning Policy 1 – State Planning Framework.
- ii) State Planning Policy 7.3 Residential Design Codes Volume 1.
- iii) ...

##### (c) Relationship to other local planning policies

This policy has due regard to, and should be read in conjunction with the [decision-maker] other local planning policies. Of particular relevance to this policy are:

- i) ...

##### (d) Other

This policy shall also be read in conjunction with the following:

- i) ...





## Appendices

[Return to contents page](#)

### Appendices

Appendix 1:  
R-Codes Volume 1  
approval application and  
determination forms

Appendix 2:  
Local Planning Policy  
prepared via State Planning  
Policy 7.3 Residential Design  
Codes Volume 1

Appendix 3:  
Local development plan  
proforma

### 5.0 Policy statement

#### *Local housing objectives*

- 6.1 Local housing objectives describe [*decision-maker's*] intent for residential development in the [*policy area*], and are set out in [*local planning strategy*].
- 6.2 Local housing objectives will guide judgements about the merits of proposals for residential development in [*policy area*].

#### *Deemed-to-comply proposals*

- 6.3 The deemed-to-comply provisions of the R-Codes Volume 1 apply except as specified below:
  - 6.3.1 [*Include R-Code Volume 1 clause number and deemed-to-comply provision to be varied and corresponding new clause(s)*].

#### *Proposals against design principles*

- 6.4 Any element of a proposal that does not meet the deemed-to-comply provisions will be assessed against the relevant design principles of the R-Codes Volume 1.
- 6.5 The following policy provisions will be considered in the determination of proposals that apply the design principles:
  - 6.5.1 [*Include R-Code Volume 1 clause number and design principle and corresponding provisions to guide decision-making regarding application of each particular design principle*].



## Appendices

### Appendix 3: Local development plan proforma

[Return to contents page](#)

#### Appendices

Appendix 1:  
R-Codes Volume 1  
approval application and  
determination forms

Appendix 2:  
Local Planning Policy  
prepared via State Planning  
Policy 7.3 Residential Design  
Codes Volume 1

Appendix 3:  
Local development plan  
proforma

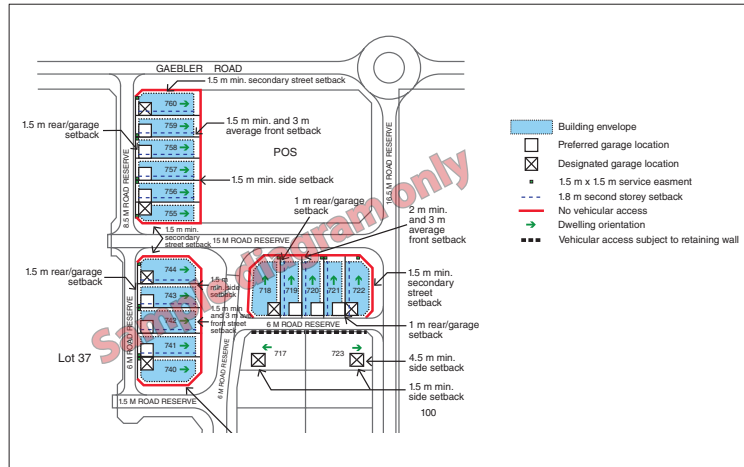

#### Development standards

The requirements of the R-Codes Volume 1 apply unless otherwise provided below. The following standards constitute amendments to the R-Codes Volume 1 and operate as deemed-to-comply requirements.

##### Context

- Local development standards that replace/amend deemed-to-comply provisions:
  - Street setbacks: clause 5.1.2
  - Lot boundary setbacks: clauses 5.1.3 C3.2-3.3
  - Building height: clauses 5.1.6

##### Streetscape

- Buildings on boundary – local development standards that replace/amend deemed-to-comply provisions:
  - setback of garages and carports: clause 5.2.1
  - garage width: clause 5.2.2
  - street surveillance: clause 5.2.3
  - street walls and fences: clause 5.2.4
  - sight lines: clause 5.2.5
  - appearance of retained dwelling: clause 5.2.6

##### Site planning and design

- Local development standards that replace/amend deemed-to-comply provisions:
  - site works clause 5.3.7

##### Building design

- Local development standards that replace/amend deemed-to-comply provisions:
  - external fixtures: clause 5.4.4

##### Special purpose dwellings

- Additional dwelling types: clause 5.5.2 C2.1ii

##### Standards

Other relevant development standards for elements not addressed by the R-Codes Volume 1, for example, requirements for rear laneway lots to address the primary street or public open spaces, requirements for corner lots to address the secondary street, rainwater tank provision, designated garage locations and so on.

The local development plan has been adopted by  
[decision-maker] on [insert date] / approved  
under delegated authority by:

\_\_\_\_\_  
[Name, Title of Responsible Officer]

\_\_\_\_\_  
Date

