



ROAM CONSULTING

ENERGY MODELLING EXPERTISE

ROAM Consulting Pty Ltd
A.B.N. 54 091 533 621

Report (Imo00016) to



Assessment of FCS and Technical Rules

21 July 2010



VERSION HISTORY

Version History				
Revision	Date Issued	Prepared By	Approved By	Revision Type
0.8	2010-04-14	Jenny Riesz Sam Shiao		Preliminary results
1	2010-04-15	Jenny Riesz Sam Shiao	Ian Rose	Complete Draft
1.1	2010-05-21	Jenny Riesz Andrew Turley	Ian Rose	Revised Draft
1.2	2010-07-21	Jenny Riesz	Ian Rose	Revised Draft (in progress)
1.3	2010-07-21	Jenny Riesz	Ian Rose	Report

EXECUTIVE SUMMARY

In this package of work ROAM Consulting (ROAM) has conducted an analysis of the Frequency Control Service (FCS) requirements in the South West Interconnected System (SWIS) for different penetration levels of intermittent renewable energy generation.

The following significant conclusions and recommendations have come from this analysis:

The load following requirement increases substantially in response to penetration of intermittent generation (Section 7)

The load following requirement increases from the current value of 60 MW to 200-300 MW by 2030. The load following requirement is found to increase by 5-40% of the capacity of new installed wind farms, depending upon the location of the new wind farm (and its output correlation with others previously installed). On average, 14% of the capacity of the new wind farm is added to the load following requirement.

Projected load following requirements can be technically provided under the existing rules and with existing infrastructure (Section 7.3)

To provide 300 MW of load following, Verve would need to dispatch 548 MW of OCGT plant on a continuous basis approximately half loaded. This can technically be provided by existing Verve plant. However, this is likely to be an inefficient and relatively expensive way to provide such a large quantity of load following service, and utilisation of opportunities to provide this service more efficiently are recommended.

Recommendation - Introduce a competitive market for the provision of ancillary services

By introducing an effective market for the provision of ancillary services, load following can be provided by the plant which can do so most efficiently. A co-optimised energy and reserve market similar to that in the NEM is suggested for further investigation.

Inertia and governor response are not limiting factors (Section 11.3)

This study suggests that if the existing definition for load following is used to allocate load following plant, the system frequency can be maintained to a sufficient level through the governor response of those units. This suggests that the existing methodology in use by System Management for maintaining system frequency (definition provided in clause 3.10.1 of WEM Rules) is sufficient, and is likely to remain sufficient. In almost all cases no additional governor response is required, and system inertia does not become an issue. If additional fast response service is required, it is most effectively provided through an increased governor response (rather than through increasing system inertia). This could be provided with relative ease by tuning the governors of a wider range of plant.

Recommendation - Arduous requirements for wind farms to provide system inertia should not be applied. Clause 3.10.1 of the WEM Rules is a sufficient standard for the Load Following service.

The existing load following definition is sufficient (Section 5)

The current methodology for calculating the load following requirement does not account for "slow following" requirements (large, slow, coarse grained response load following), and "fast response" requirements (frequency control within one minute). ROAM developed metrics to account for these components, which were used to determine if they would become a problem in the event of high wind penetration (section 5). This report shows that these additional metrics are not likely to become an issue in the event of high wind penetration (section 7.2), and the existing definition of the load following service is likely to remain sufficient (section 11.3). Clause 3.10.1 of the WEM Rules is likely to remain a sufficient definition for the Load Following service for maintaining frequency within the limits required in the Technical Rules.

Equations in the Rules for determination of costs of load following are flawed (Section 14)

The equations defined in the existing WEM rules for the determination of the costs of the load following service are flawed (clause 9.9.2 of WEM Rules). They do not allow for the situation where the load following requirement exceeds the spinning reserve requirement, which is likely to occur in the next few years. They also do not correctly account for load following services provided by contract (from providers other than Verve).

Recommendation - The methodology in the Rules for the determination of the costs of load following and spinning reserve (clause 9.9.2 of WEM Rules) should be updated as a priority (suggested equations proposed in section 14.4).

The existing equations (clause 9.9.2 of the WEM Rules) are likely to become inadequate within the next few years. Alternative equations are proposed in the body of this report that address these immediate issues (section 14.4). Clauses 3.13.3, 3.13.3A and 3.22.1 are also affected (proposed revised texts are provided in section 14.4).

Recommendation - An efficient market for frequency control ancillary services should be established

The establishment of an efficient market for load following and spinning reserve services would avoid determining the costs of providing these services via arbitrary equations with the need for constant revision of calibration factors.

Establishment of a market for ancillary services (specifically load following and spinning reserve) would require revision of the following clauses in the WEM Rules: 3.11.7 (planning), 3.11.7A (Electricity Generation Corporation), 3.11.8, 3.11.8E, (contracts), 3.13.1 (payment for ancillary services), 3.13.3, 3.13.3A (calibration of Margin_Peak and Margin_Off-peak), 9.9.1, 9.9.2 (settlement amount), 9.9.3, 9.9.4 (contracts).

The following clauses may also require revision, depending upon the nature of the market established: 3.11.9 (cost minimisation), 3.11.10, 3.11.11 (contract reporting), 3.11.12, 3.11.13 (planning and reporting), 3.11.14 (tender process reporting), 3.11.15 (market procedure), 3.12.1

(dispatch of ancillary services), 3.13.1A (settlement information), 3.13.2 (payments for ancillary services).

The cost of load following increases as wind levels increase (Section 14.8)

With the levels of wind penetration studied in this report (1000 MW by 2020 and 1700 MW by 2030) the costs of providing the load following service calculated using the existing methodology increase from current levels. With high wind penetration the total cost of load following increases from:

- \$10 million in 2008-09 to
- \$50-65 million by 2014-15,
- \$55-75 million by 2020 and
- \$65-90 million by 2030.

These projected costs equate to a 5 to 6 fold increase in total load following costs by 2014-15, and a 6 to 9 fold increase in total load following costs by 2030 (assuming that the existing rules continue to be applied). These costs are based upon the assumption that existing Rules and market conditions continue; costs could be much higher under alternative assumptions (for example, with higher gas prices, or a carbon price, as explored in section 14.9).

Costs increase rapidly in early years because the load following requirement increases rapidly as more wind is introduced. At higher levels of wind penetration the variability increases less (due to aggregation and geographical distribution of wind farms), so costs increase less dramatically in the later years of the study.

Cost projections are sensitive to changes in assumptions (Section 14.9) (Section 14.8.2)

If intermittent generators are responsible for the marginal cost of load following, they experience annual costs of \$20,000 - 55,000 per MW of installed wind capacity (based upon the assumption that existing market conditions continue). At a 40% capacity factor this equates to \$6-16 /MWh. Although this is a substantial cost, installation of wind in the SWIS could remain competitive with areas in the NEM due to the excellent wind resource available (40% capacity factor compared with 30% in South Australia, for example).

However, costs are found to be dependent on a range of assumptions, including the gas price and the presence (or absence) of an emissions trading scheme. Depending upon the assumptions used, costs could be much higher than those calculated based on the assumption that the existing Rules and market conditions continue (as used in section 14.8). Costs could be higher than \$300 million per annum by 2030, equating to \$50-\$60 /MWh in ancillary services costs for intermittent generators. This highlights the importance of various highly uncertain input assumptions in cost projections.

Recommendation - Introduce a competitive market for the provision of ancillary services

By introducing an effective market for the provision of ancillary services, load following costs can be minimised. It is important that the various opportunities for reducing load following costs (such as their provision by plant other than Verve) are thoroughly investigated.

Recommendation - Actively seek opportunities to minimise load following costs.

Opportunities for minimising costs could include:

- Implementing a competitive market for ancillary services, allowing utilisation of the most efficient plant for provision of load following
- Implement market design changes to incentivise the commercial entry of technologies that can most cost effectively meet load following requirements
- Utilising plant other than OCGT plant for load following
- Utilising plant other than Verve plant for load following
- Investigating new technologies specifically designed for load following service (for example, the LMS100 units dramatically reduce load following costs)
- Investigating opportunities to minimise load following requirements, such as through
 - Effective wind forecasting
 - Allowing expanded frequency limits
 - More nuanced management of aggregate intermittent generation
 - Limiting aggregate maximum ramp-up rates for wind farms
 - Varying the load following requirement by time of day, or depending upon the current output level of intermittent generation

ROAM recommends commissioning analysis to determine the relative effectiveness of these and other methods for reducing load following costs.

The division of cost between load following and spinning reserve needs review (section 14.9)

This analysis suggests that the existing methodology in the Rules for allocating availability costs between load following and spinning reserve is inaccurate (clause 9.9.2 of the WEM Rules). Although Verve can recover the same quantity of revenue regardless of the cost distribution, different market participants are responsible for the costs of load following and spinning reserve. This means that the relative proportions of the costs of these services is important.

Recommendation - Review the methodology in the Rules for allocating the costs of spinning reserve and load following (clause 9.9.2).

Due to the different nature of the spinning reserve and load following services it is strongly recommended that a review of their relative costing in the Rules is undertaken. This can be achieved by modelling calculating these costs independently (rather than in aggregate). ROAM has proposed a detailed methodology and updated clause 9.9.2 incorporating changes that would address this issue. Over the longer term, the division of these costs could be most effectively achieved through the implementation of a competitive market for frequency control ancillary services.

Intermittent generators should pay the marginal cost of load following (Section 14.10)

60-80% of the load following requirement is projected to be due to intermittent generation, but if intermittent generators were required to pay this proportion of the load following cost, system loads would obtain a "wind-fall" gain through wind generation assuming their costs. Since load variability must be managed via a load following service as an inherent part of operating the system, intermittent generators should only be responsible for the costs of load following services in excess of this amount. This makes intermittent generators responsible for 50-60% of the costs of load following.

Recommendation - Intermittent generators should pay the marginal cost of the provision of the load following service, above that required for load variability

This will require revision of clause 3.14.1 in the WEM Rules (allocation of load following costs). An alternative proposed drafting of this clause is provided in the body of the report (section 14.10.1).

Dispatch priorities at time of minimum load will become important (Section 12)

In the most extreme scenario, by 2020-21 the installed wind capacity plus cogeneration and ancillary services capacity exceeds the annual minimum load. In the exceedingly rare circumstance that all installed wind farms were operating close to maximum capacity at the time of minimum load, this would mean that one or both of the following would need to occur to manage the system:

- Some (or all) wind farms would need to be curtailed
- Some (or all) large thermal plants would need to be shut down.

Importantly, the load is only forecast to be this low on one evening of the year. All other overnight troughs will have higher loads. In addition, due to geographical diversity of wind farms it will be a rare event to approach 100% output of all wind farms simultaneously. It is even more exceedingly unlikely that this event will occur at time of minimum load. Finally, this is the case only in the most extreme scenario (other scenarios have significantly lower quantities of installed wind). However, these results do suggest the increasing importance of transparent dispatch order priorities, particularly around overnight troughs.

Recommendation - Implement transparent dispatch merit order priorities in the SWIS

The current dispatch merit order priorities in the SWIS are far from a free cost-based and transparent market. This is likely to become a significant issue in the near future, and should be addressed as a priority. Market design changes should be investigated to provide a technically feasible least-cost outcome.

Facilities for wind curtailment are likely to be necessary (Section 12)

With high quantities of wind installed it is likely to become important that system management has the ability to curtail wind farms if necessary to manage the system.

Recommendation - Intermittent generators must be able to curtail if necessary

It is important that sufficient installed intermittent generation of consequence has the facilities to curtail output if required (as is required by the existing Market Rules).

Ramping limits on intermittent generators are ineffective at reducing variability (Section 15)

There is currently a requirement in the technical rules for the SWIS that non-scheduled generators do not increase or decrease their active power generation at a rate greater than 15% of the generator machine's nameplate rating per minute. This was found to be completely ineffective at reducing the load following requirement. To produce a significant reduction in the load following requirement it was necessary to reduce this ramp limit to 0.2% of the capacity of the wind farm. At this level, wind farms were curtailing 20% of their energy, which is clearly an inefficient result.

Recommendation - Ramp limits should not be applied to intermittent generators individually.

It may be effective to control aggregate ramping of intermittent generation, but this would be best achieved on a case-by-case basis by System Management as required. System Management has indicated that in their observations, whilst major ramp ups can occur across the wind farm fleet they are reasonably rare, normally occurring when major weather patterns (such as fronts) cross the coast.

Intermittent generation is unlikely to be an attractive provider of load following service (Section 16)

While intermittent generators may have the technical ability to provide load following services, this would involve curtailing output by the amount of the load following requirement (20-30% of total capacity below available output). This involves sacrificing the substantial revenue available from the sale of electricity and Renewable Energy Certificates, and is unlikely to be competitive with the costs of ancillary services provided by Verve (or other thermal generation). Intermittent generators may be incentivised to provide load following services only if they are regularly curtailed by a large amount, in which case they can provide the load following service without sacrificing revenue, and possibly increase output if other load following plant can be taken offline.

Recommendation - Facilitating intermittent generators to provide load following services should not be an immediate priority.

Wind exhibits correlation within three distinct zones in the SWIS (Section 6.1.2)

Analysis conducted for this study indicates that wind generator output is likely to be correlated within three distinct zones: North coast (Geraldton and surrounds), around Perth, and South coast (Albany and surrounds). Distributing wind generation evenly across these zones will yield the most moderate outcome for load following requirements. Locating a new wind farm in an area that is uncorrelated with existing wind farms is shown to increase the load following requirement by only 5% of the capacity of the wind farm. However, locating a new wind farm in an area that is highly correlated with existing wind farms can increase the load following requirement by 40% of the capacity of the wind farm.

Recommendation - Consider commissioning a detailed wind correlation study

It is important that wind farm developers have access to information relevant to their locational decisions. However, there is currently very little information available on wind correlation around the SWIS and its impacts on ancillary service requirements. Combined with appropriate incentives (such as intermittent generators being responsible for the correct proportion of the costs of ancillary services), this information could drive better wind locational decisions for the SWIS to minimise load following requirements. This study will also facilitate understanding the degree of curtailment and the incidence of curtailment of wind production needed to implement other recommendations (in particular those associated with section 12)¹.

¹ Commissioning a study of this nature would necessitate sharing of hub height wind data at a one minute resolution, which has previously proved problematic.

TABLE OF CONTENTS

1) BACKGROUND	1
1.1) FREQUENCY CONTROL ANCILLARY SERVICES	1
1.2) SOUTH WEST INTERCONNECTED SYSTEM (SWIS) RULES	2
2) SCOPE	4
3) METHODOLOGY	4
4) GENERATION PLANTING SCENARIOS	5
5) METRICS FOR ASSESSING LOAD FOLLOWING REQUIREMENTS	11
5.1) CURRENT METHODOLOGY	11
5.2) PROPOSED ALTERNATE METHODOLOGY	14
5.3) SLOW FOLLOWING SERVICE	16
5.4) REGULATION SERVICE	16
5.5) FAST RESPONSE SERVICE	17
5.6) ILLUSTRATIVE EXAMPLE OF ALTERNATE METHODOLOGY	17
6) WIND AND DEMAND MODELLING	21
6.1) WIND ENERGY SIMULATION TOOL (WEST)	21
6.1.1) <i>Calibration of WEST</i>	22
6.1.2) <i>Wind farm correlations</i>	25
6.2) LOAD FORECASTING	26
6.3) CALCULATION OF LOAD FOLLOWING REQUIREMENTS	27
7) LOAD FOLLOWING REQUIREMENTS - RESULTS	27
7.1) EXISTING LOAD FOLLOWING DEFINITION	27
7.2) PROPOSED ALTERNATIVE DEFINITION	33
7.2.1) <i>Fast response service</i>	33
7.2.2) <i>Regulation service</i>	36
7.2.3) <i>Slow following service</i>	40
7.3) ABILITY OF PLANT TO PROVIDE REQUIRED LOAD FOLLOWING SERVICES	43
8) DISPATCH MERIT ORDER	44
9) SYSTEM FREQUENCY MODEL	48
9.1) DEVELOPMENT OF THE SYSTEM FREQUENCY MODEL	48
9.1.1) <i>Generator and Load Model</i>	49
9.1.2) <i>Governor-Turbine Models</i>	50
10) CALIBRATING THE SYSTEM FREQUENCY MODEL	55
10.1) BENCHMARKING AGAINST HISTORIC EVENTS	55
10.1.1) <i>Contingency 1</i>	55
10.1.2) <i>Contingency 2</i>	57
11) FAST RESPONSE REQUIREMENTS - FREQUENCY MODELLING	58
11.1) SYSTEM LOAD AND INERTIA	59

11.2)	ASSIGNMENT OF GOVERNOR RESPONSIVE UNITS	59
11.3)	FREQUENCY MODELLING RESULTS	60
12)	ISSUES ASSOCIATED WITH PROVISION OF ANCILLARY SERVICES.....	62
13)	EXPERIENCES IN OTHER MARKETS.....	67
13.1)	MARKETS WITH SIGNIFICANT INTERCONNECTION	68
13.1.1)	<i>Germany</i>	68
13.1.2)	<i>Denmark</i>	68
13.2)	MARKETS WITH LOW INTERCONNECTION	69
13.2.1)	<i>South Australia (NEM)</i>	69
13.2.2)	<i>EIRE (Republic of Ireland)</i>	72
14)	COSTS OF ANCILLARY SERVICES.....	73
14.1)	EXISTING RULES FOR FUNDING OF LOAD FOLLOWING.....	73
14.2)	EXISTING CALCULATION OF LOAD FOLLOWING COSTS.....	74
14.3)	REVISED COST CALCULATION	79
14.3.1)	<i>Total Availability Cost</i>	80
14.3.2)	<i>If SR Requirement > LF Requirement</i>	80
14.3.3)	<i>If LF Requirement > SR Requirement</i>	82
14.3.4)	<i>Calibration of $MSR_{p(op)}$, $MLF_{p(op)}$, $\theta_{p(op)}$ and $\gamma_{p(op)}$</i>	84
14.4)	REVISED COST CALCULATION IN WEM RULES TERMINOLOGY	89
14.4.1)	<i>Proposed revised Clause 9.9.2</i>	89
14.4.2)	<i>Proposed revised clause 3.13.3</i>	93
14.4.3)	<i>Proposed revised clause 3.13.3A</i>	93
14.4.4)	<i>Proposed revised clause 3.22.1</i>	94
14.4.5)	<i>Establishment of a market for ancillary services</i>	95
14.5)	ACCURACY OF COST CALCULATIONS.....	96
14.6)	ANCILLARY SERVICES IN THE NEM	96
14.7)	HISTORICAL COSTS OF LOAD FOLLOWING SERVICE	97
14.8)	PROJECTION OF FUTURE COSTS.....	98
14.8.1)	<i>Capacity Costs</i>	98
14.8.2)	<i>Availability costs</i>	100
14.8.3)	<i>Total costs of load following</i>	105
14.9)	CALCULATION OF COSTS FROM DISPATCH MODELLING	108
A.1)	DIFFERENCES IN PROJECTED COSTS OF LOAD FOLLOWING - SUMMARY.....	117
14.10)	ALLOCATION OF COSTS.....	119
14.10.1)	<i>Revision of WEM Rules</i>	124
15)	MODERATION OF INTERMITTENT GENERATORS TO REDUCE LOAD FOLLOWING REQUIREMENT	125
16)	INTERMITTENT GENERATION PROVIDING ANCILLARY SERVICES.....	128
16.1)	WIND FARMS CONTRIBUTING INERTIA	128

16.2)	CURTAILMENT TO PROVIDE REGULATION.....	130
16.2.1)	<i>Technical feasibility</i>	130
16.2.2)	<i>Cost analysis</i>	131
17)	CONCLUSIONS AND RECOMMENDATIONS.....	133
17.1)	RECOMMENDATIONS.....	137
APPENDIX A)	LIST OF STATIONS IN THE SWIS.....	1
APPENDIX B)	PLANTING SCHEDULES FOR SCENARIOS	5
APPENDIX C)	DISPATCH MERIT ORDER	12
APPENDIX D)	PLANT PROVIDING LOAD FOLLOWING	17
APPENDIX E)	PLANT ONLINE PROVIDING INERTIA	18
APPENDIX F)	DISPATCH MODELLING WITH 2-4-C.....	22
F.1)	MODELLING ASSUMPTIONS	22

LIST OF TABLES

TABLE 4.1 - SUMMARY OF SCENARIOS.....	5
TABLE 4.2 - CAPACITY OF WIND INSTALLED BY SCENARIO	6
TABLE 6.1 – CORRELATION FACTORS OF WIND DATA (2008-09)	25
TABLE 7.1 - FORECAST LOAD FOLLOWING REQUIREMENT - EXISTING DEFINITION (MW)	27
TABLE 7.2 - FORECAST LOAD FOLLOWING REQUIREMENT - EXISTING DEFINITION - SCENARIO 1	30
TABLE 7.3 - FORECAST LOAD FOLLOWING REQUIREMENT - EXISTING DEFINITION - SCENARIO 2	31
TABLE 7.4 - FORECAST LOAD FOLLOWING REQUIREMENT - EXISTING DEFINITION - SCENARIO 3	32
TABLE 7.5 - FORECAST LOAD FOLLOWING REQUIREMENT - EXISTING DEFINITION - SCENARIO 4	32
TABLE 7.6 - FAST RESPONSE SERVICE REQUIREMENT (SCENARIO 1).....	34
TABLE 7.7 - FAST RESPONSE SERVICE REQUIREMENT (SCENARIO 2).....	35
TABLE 7.8 - FAST RESPONSE SERVICE REQUIREMENT (SCENARIO 3).....	35
TABLE 7.9 - FAST RESPONSE SERVICE REQUIREMENT (SCENARIO 4).....	36
TABLE 7.10 - REGULATION SERVICE REQUIREMENT (SCENARIO 1).....	37
TABLE 7.11 - REGULATION SERVICE REQUIREMENT (SCENARIO 2).....	38
TABLE 7.12 - REGULATION SERVICE REQUIREMENT (SCENARIO 3).....	39
TABLE 7.13 - REGULATION SERVICE REQUIREMENT (SCENARIO 4).....	39
TABLE 7.14 - FORECAST SLOW FOLLOWING SERVICE REQUIREMENT (SCENARIO 1)	41
TABLE 7.15 - FORECAST SLOW FOLLOWING SERVICE REQUIREMENT (SCENARIO 2)	41
TABLE 7.16 - FORECAST SLOW FOLLOWING SERVICE REQUIREMENT (SCENARIO 3)	42
TABLE 7.17 - FORECAST SLOW FOLLOWING SERVICE REQUIREMENT (SCENARIO 4)	43
TABLE 8.1 – PRINCIPLES OF DISPATCH MERIT ORDER	45
TABLE 8.2 – COMPARISON OF DISPATCH OF COAL-FIRED GENERATION AND WIND GENERATION	46
TABLE 9.1 – SWIS GENERATORS AND THE CORRESPONDING GOVERNOR-TURBINE MODELS	51
TABLE 9.2 – IEESGO MODEL PARAMETERS.....	52
TABLE 9.3 – GAST2A MODEL PARAMETERS.....	53
TABLE 9.4 – IEEE11 MODEL PARAMETERS	55
TABLE 10.1 – SWIS GENERATION DISPATCH OF RESPONSIVE GENERATORS	56
TABLE 10.2 – SWIS GENERATION DISPATCH OF RESPONSIVE GENERATORS	57
TABLE 11.1 – SYSTEM LOADING APPLIED IN THE FREQUENCY MODELLING (MW)	59
TABLE 11.2 – SYSTEM INERTIA APPLIED IN THE FREQUENCY MODELLING (MWs)	59
TABLE 11.3 – TOTAL GENERATOR DISPATCH AND CAPACITY OF UNITS OFFERING GOVERNOR RESPONSE (MW)	60

TABLE 11.4 – SYSTEM FREQUENCY RESPONSE	60
TABLE 12.1 – MINIMUM LOAD COMPARED WITH LOAD FOLLOWING REQUIREMENT (SCENARIO 1)	63
TABLE 14.1 – COSTS OF ANCILLARY SERVICES (HISTORICAL)	97
TABLE 14.2 – RESERVE CAPACITY PRICES (PUBLISHED BY IMO)	99
TABLE 14.3 – CAPACITY COSTS (LOAD FOLLOWING)	99
TABLE 14.4 – AVAILABILITY COSTS (SCENARIO 1)	100
TABLE 14.5 – AVAILABILITY COSTS (SCENARIO 2)	101
TABLE 14.6 – AVAILABILITY COSTS (SCENARIO 3)	101
TABLE 14.7 – AVAILABILITY COSTS (SCENARIO 4)	102
TABLE 14.8 – LOAD FOLLOWING COSTS (SCENARIO 1)	105
TABLE 14.9 – LOAD FOLLOWING COSTS (SCENARIO 2)	106
TABLE 14.10 – LOAD FOLLOWING COSTS (SCENARIO 3)	106
TABLE 14.11 – LOAD FOLLOWING COSTS (SCENARIO 4)	107
TABLE 14.12 – AVAILABILITY COSTS OF LOAD FOLLOWING (SCENARIO 2)	110
TABLE 14.13 – TOTAL COSTS OF LOAD FOLLOWING (SCENARIO 2)	116
TABLE 14.14 – LOAD FOLLOWING COSTS (SCENARIO 1) - ALLOCATION OF COSTS	121
TABLE 14.15 – LOAD FOLLOWING COSTS (SCENARIO 2) - ALLOCATION OF COSTS	121
TABLE 14.16 – LOAD FOLLOWING COSTS (SCENARIO 1) - COSTS TO INTERMITTENT GENERATORS	122
TABLE 14.17 – LOAD FOLLOWING COSTS (SCENARIO 2) - COSTS TO INTERMITTENT GENERATORS	122
TABLE 14.18 – ALLOCATION OF COSTS OF LOAD FOLLOWING (SCENARIO 2) - DISPATCH MODELLING OUTCOMES	123
TABLE 15.1 – EFFECT OF LIMITING RAMP RATE (2030-31, SCENARIO 1) - EXISTING METRIC	126
TABLE 15.2 – EFFECT OF LIMITING RAMP RATE (2030-31, SCENARIO 1) - ALTERNATIVE METRICS	127
TABLE 15.3 – EFFECT OF LIMITING RAMP RATE (2030-31, SCENARIO 1) - EXISTING METRIC	128
TABLE A.1 – EXISTING STATIONS IN THE SWIS	1
TABLE A.2 – NEW STATIONS FOR DEVELOPMENT IN THE SWIS	2
TABLE B.1 – SCENARIO 1 PLANTING SCHEDULE	5
TABLE B.2 – SCENARIO 2 - PLANTING SCHEDULE	6
TABLE B.3 – SCENARIO 3 - PLANTING SCHEDULE	8
TABLE B.4 – SCENARIO 4 - PLANTING SCHEDULE	10
TABLE C.1 – DISPATCH MERIT ORDER	12
TABLE D.1 – PLANT AVAILABLE FOR LOAD FOLLOWING SERVICE	17
TABLE E.1 – PLANT ONLINE (SCENARIO 1)	18
TABLE E.2 – PLANT ONLINE (SCENARIO 2)	19
TABLE E.3 – PLANT ONLINE (SCENARIO 3)	20
TABLE E.4 – PLANT ONLINE (SCENARIO 4)	21
TABLE F.1 – GENERATOR OUTAGE MODELLING ASSUMPTIONS	23
TABLE F.2 – RENEWABLE GENERATOR BIDDING	26

LIST OF FIGURES

FIGURE 4.1 – SCENARIO 1 – INSTALLED CAPACITY BY TECHNOLOGY TYPE	7
FIGURE 4.2 – SCENARIO 2 – INSTALLED CAPACITY BY TECHNOLOGY TYPE	8
FIGURE 4.3 – SCENARIO 3 – INSTALLED CAPACITY BY TECHNOLOGY TYPE	9
FIGURE 4.4 – SCENARIO 4 – INSTALLED CAPACITY BY TECHNOLOGY TYPE	10
FIGURE 5.1 – LOAD DEVIATION	12
FIGURE 5.2 – WIND DEVIATION	13
FIGURE 5.3 – 60MIN DISPATCH AND SLOW FOLLOWING	18
FIGURE 5.4 – SLOW FOLLOWING AND REGULATION SERVICES	19
FIGURE 5.5 – FAST RESPONSE SERVICE	20
FIGURE 5.6 – 60MIN DISPATCH AND SLOW FOLLOWING (CONSTANT WIND)	20
FIGURE 5.7 – SLOW FOLLOWING AND REGULATION SERVICES (CONSTANT WIND)	21
FIGURE 6.1 – CALIBRATION OF WEST - ALBANY WIND FARM	24
FIGURE 6.2 – CALIBRATION OF WEST - WALKAWAY WIND FARM	24

FIGURE 7.1 – LOAD FOLLOWING REQUIREMENT (EXISTING DEFINITION)	28
FIGURE 7.2 – LOAD FOLLOWING REQUIREMENT (EXISTING DEFINITION) COMPARED WITH WIND INSTALLATION	29
FIGURE 7.3 – LOAD FOLLOWING REQUIREMENT (EXISTING DEFINITION) - WIND AND LOAD SEPARATED SCENARIO 1	31
FIGURE 7.4 – FAST RESPONSE DEVIATIONS.....	34
FIGURE 7.5 – REGULATION REQUIREMENT	37
FIGURE 7.6 – SLOW FOLLOWING REQUIREMENT	40
FIGURE 9.1 – SYSTEM FREQUENCY MODEL	49
FIGURE 9.2 – IESGO GOVERNOR/TURBINE MODEL	52
FIGURE 9.3 – GAST2A GOVERNOR-TURBINE MODEL	53
FIGURE 9.4 – IEEE11 GOVERNOR-TURBINE MODEL	54
FIGURE 10.1 – SIMULATED AND ACTUAL SYSTEM FREQUENCY RESPONSE FOR CONTINGENCY	56
FIGURE 10.2 – SIMULATED AND ACTUAL SYSTEM FREQUENCY RESPONSE FOR CONTINGENCY	58
FIGURE 12.1 – SCENARIO 1 - MINIMUM LOAD COMPARED WITH INSTALLED WIND CAPACITY	64
FIGURE 12.2 – SCENARIO 2 - MINIMUM LOAD COMPARED WITH INSTALLED WIND CAPACITY	65
FIGURE 12.3 – SCENARIO 3 - MINIMUM LOAD COMPARED WITH INSTALLED WIND CAPACITY	66
FIGURE 12.4 – SCENARIO 4 - MINIMUM LOAD COMPARED WITH INSTALLED WIND CAPACITY	66
FIGURE 13.1 – WIND DEVELOPMENT IN SOUTH AUSTRALIA	70
FIGURE 14.1 – CUSTOMER COST OF ANCILLARY SERVICES IN THE NEM	97
FIGURE 14.2 – AVAILABILITY COSTS ($M_p = 30\%$)	105
FIGURE 14.3 – COSTS OF LOAD FOLLOWING SERVICE ($M_p = 30\%$)	108
FIGURE 14.4 – AVAILABILITY COST OF LOAD FOLLOWING SERVICE (SCENARIO 2) IMPACT OF VERVE GAS PRICE	112
FIGURE 14.5 – AVAILABILITY COST OF LOAD FOLLOWING SERVICE (SCENARIO 2) IMPACT OF LOAD FOLLOWING REQUIREMENT	113
FIGURE 14.6 – AVAILABILITY COST OF LOAD FOLLOWING SERVICE (SCENARIO 2) IMPACT OF CARBON PRICE	114
FIGURE 16.1 – PERCENTAGE OF TOTAL WIND FARM CAPACITY REQUIRED TO BE CURTAILED TO PROVIDE LOAD FOLLOWING SERVICE	133

1) BACKGROUND

The Renewable Energy Generation Working Group (REG WG) is tasked with the review and investigation of potential issues associated with high levels of penetration of intermittent renewable energy generation projects within the South West Interconnected System (SWIS).

The REG WG has been established under the auspices of the Market Advisory Committee (MAC). The working group has been tasked with investigating the range of issues presented by renewable energy generators and to develop and propose solutions to the various issues.

The REG WG has established an overall Work Program to address these issues which broadly comprise the following four Work Packages:

- Work Package 1: Impacts from State and National Policy
- Work Package 2: Reserve Capacity and Reliability Impacts
- Work Package 3: Frequency Control Services
- Work Package 4: Technical Rules

This report summarises the work conducted by ROAM Consulting (ROAM) for Work Package 3.

1.1) FREQUENCY CONTROL ANCILLARY SERVICES

The frequency of an electrical system will change in response to an imbalance between generation and load; an excess of generation will cause the frequency to rise, whereas a lack of generation will cause the frequency to fall. It is important that the frequency is maintained within a narrow band, so that it remains within the operating parameters of the loads and generators connected to the system.

The frequency must be maintained in a number of ways. Firstly, there must be constant adjustment such that as the load and output of intermittent generation changes, the generation and load are constantly matched. In the existing system, this is mostly achieved through the use of a generator providing a "load following" service, increasing or decreasing output incrementally on a continuous basis as required. In theory this service could also be provided by a load if one existed that was willing to vary consumption on a minute to minute basis.

The frequency must also be maintained in the event of a sudden contingency, such as a generation unit unexpectedly experiencing an outage, or a sudden transmission fault. In these events a large quantity of generation will suddenly go offline and must be rapidly replaced². This service is provided by plant offering "spinning reserve", typically operating close to minimum load so that they can rapidly increase output if required.

² A sudden transmission fault may also cause a reduction in the load level, due to the voltage depression, even if no substations are disconnected as a result of the fault. This can offset some of the lost generation, reducing the spinning reserve requirement.

Similarly, if a large load were to suddenly experience a fault a corresponding amount of generation would need to be rapidly taken offline. This service is provided by plant offering "load rejection reserve".

1.2) SOUTH WEST INTERCONNECTED SYSTEM (SWIS) RULES

Ancillary Services in the SWIS

The following frequency control ancillary services are defined in the SWIS Market Rules³:

- **Load Following.** Load following is the primary mechanism in real-time to ensure that supply and demand are balanced. Load following accounts for the difference between scheduled energy and actual load and intermittent generation. Load following resources must have the ramping capability to pick up the load ramp between scheduling steps as well as maintain the system frequency. Load following may be provided by units operating under Automatic Generation Control (AGC), or through manual control.
- **Spinning Reserve.** This service holds capacity in reserve to respond rapidly should another unit experience a forced outage. The capacity would include on-line generation capacity and interruptible loads (i.e. loads that respond automatically to frequency drops).
- **Load Rejection Reserve.** This service requires that generators be maintained in a state in which they can rapidly decrease their output should a system fault result in the loss of load. This service is particularly important overnight when most generating units in the system are operating at minimum loading and have no capability to decrease their output in the time frame required.

In this study, we are interested in the implications of the introduction of a large quantity of intermittent generation (mostly wind generation) in the SWIS. This could be expected to have a significant impact upon the load following service, due to the increased variability required of scheduled generation. This effect has been observed in other electricity systems internationally, including California^{4 5}, Ireland^{6 7}, Germany⁸ and Nordic countries⁹.

The other frequency control ancillary services are likely to be less significantly affected by the penetration of intermittent generation. The spinning reserve service is dependent upon the largest single unit online, which will remain unchanged by the introduction of large quantities of

³ <http://www.imowa.com.au/n234.html>

⁴ Y. V. Marakov, C. Loutan, J. Ma, P. de Mello, S. Lu, "Impacts of Integration of Wind Generation on Regulation and Load Following Requirements of California Power Systems", IEEE, 2008.

⁵ Y. V. Marakov, D. Hawkins, "Quantifying the impact of wind energy on power system operating reserves", Proc. Global WindPower Conf and Exhibition, March 28-31, 2004, Chicago.

⁶ R. Doherty, A. Mullane, G. Nolan, D. Burke, A. Bryson and M. O'Malley. "An Assessment of the Impact of wind Generation on System Frequency Control". IEEE Transactions on Power Systems, Vol. 25, No. 1, Feb 2010.

⁷ S. Twohig, K. Burges, C. Nabe, A. Crowe, K. Polaski and M. O'Malley. "Ultra High Wind Energy Penetration in an Isolated Market", IEEE, 2008.

⁸ G. Dany, "Power Reserve in Interconnected Systems with High Wind Power Production", IEEE, 2001.

⁹ H. Holttinen, "Impact of hourly wind power variations on the system operation in Nordic countries", Wind Energy, vol. 8, pp. 197-218, 2005.

intermittent generation (since these are typically composed of many small units). Similarly, the load rejection reserve should be minimally affected, since it is dependent solely upon the properties of the system load.

Load following in the SWIS

The existing load following WEM Rules require that sufficient plant (mostly open cycle gas turbines (OCGTs)) be online to meet fluctuations in wind and demand in 99.9% of all periods¹⁰. This is derived as being necessary to the frequency standards defined in the Technical Rules (the frequency must be maintained between 49.8 to 50.2 Hz for 99% of the time).

Currently, 60 MW of load following capacity is required to be online in all periods. If significant new intermittent generation is constructed, the load following plant required will continue to rise. High WA gas prices are also likely to limit the installation of new gas plant, or at least increase the total cost of WA generation, and thus reduce the flexibility of dispatch to accommodate increasing amounts of wind.

A report by Econnect in 2005¹¹ suggested that frequency stability is likely to become a significant issue once wind penetration exceeds 20-30% of total energy. By comparison, 1000 MW of wind generation in the SWIS would contribute around 15% of projected energy consumption. International experience suggests that from 10% (energy) penetration some wind curtailment becomes necessary to maintain system security. From 20% (energy) penetration the curtailment of wind becomes significant, with around 10% of annual wind energy being discarded^{12 13}. Applying this rule of thumb to the SWIS would suggest that wind penetration of around 500 MW is likely to be achievable without significant system-wide effects, whereas wind installation around 1000 MW is likely to require much more substantial management. However, as an isolated grid, the SWIS may experience deleterious effects earlier than other more interconnected grids.

Wholesale Electricity Market (WEM) Objectives

Any changes recommended in light of the analysis in this study must be consistent with the Wholesale Market Objectives. These are¹⁴:

- (a) to promote the economically efficient, safe and reliable production and supply of electricity and electricity related services in the South West interconnected system;
- (b) to encourage competition among generators and retailers in the South West interconnected system, including by facilitating efficient entry of new competitors;

¹⁰ SWIS Market Rules

¹¹ Econnect report, *Maximising the Penetration of Intermittent Generation in the SWIS*, 2005

¹² CER/OFREG NI. Impacts of increased levels of wind penetration on the electricity systems of the Republic of Ireland and Northern Ireland: final report. A Report commissioned by the Commission for Energy Regulation in the Republic of Ireland and OFREG Northern Ireland, 2003.

¹³ G. Giebel. On the benefits of distributed generation of wind energy in Europe (Fortschr.-Ber. VID, Reihe 6, Nr 444). VDI: Dusseldorf, 2001.

¹⁴ SWIS Market Rules

- (c) to avoid discrimination in that market against particular energy options and technologies, including sustainable energy options and technologies such as those that make use of renewable resources or that reduce overall greenhouse gas emissions;
- (d) to minimise the long-term cost of electricity supplied to customers from the South West interconnected system; and
- (e) to encourage the taking of measures to manage the amount of electricity used and when it is used.

2) SCOPE

In this package of work, ROAM is asked to:

- Determine whether the existing spinning reserve, load following, curtailment and demand response criteria in the SWIS are adequate for the forecast levels of intermittent generation, and the projected scenarios for the overall generation mix. The scenarios and penetration levels at which additional services are required will be identified;
- Determine whether intermittent generators can be used to provide the frequency control services required including load following for overnight load troughs; and
- Determine the cost and the method of allocating of these costs associated with the provision of frequency control services for the forecast penetration levels of intermittent generation.

3) METHODOLOGY

ROAM has taken the following approach to this package of work:

1. Develop appropriate metrics for determination of load following requirements in the SWIS.
2. Obtain available wind and demand data at one minute resolution, and utilise these to extrapolate one minute wind farm output and demand traces for the years of the study (2009-10 to 2030-31). Wind farm development schedules for four scenarios developed in Work Package 1 were used as an input.
3. Based upon these traces, calculate the load following requirements of each type in each year for each scenario, according to the developed metrics.
4. Determine an appropriate dispatch merit order for the SWIS, including which plant must be dispatched for load following service in each year. This dispatch will vary according to the plant installed in each year in each scenario.

System frequency modelling (fast response)

5. Develop a system frequency model for analysis of necessary fast response dynamics.
6. Calibrate the system frequency model to the SWIS utilising contingency data.
7. Based upon the one minute resolution wind and demand traces developed previously, determine the system disturbances in the one minute timeframe that will occur at the 99th percentile in each scenario in each year.
8. Input to the system frequency model the wind disturbances at the one minute level, and determine the necessary governor response that will be required to maintain system frequency in the fast response timeframe. A constant ramp over the one minute period

is used (matched to the 99th percentile disturbance from the one minute data), to analyse dynamics within the one minute timeframe. Inertia of the plant online will be determined utilising the dispatch merit order previously developed. Disturbances at various times will be considered, including time of minimum load, time of maximum load and a time of intermediate load.

It should be noted that many system frequency dynamics occur on timeframes much smaller than one minute. However, one minute resolution historical wind and load data was the smallest resolution available for this study. The 99th percentile one minute shift was determined from this data and used as an input to the much finer resolution frequency model, as a constant ramp over one minute. This allows analysis of system frequency dynamics on timeframes much shorter than one minute, but does assume that there are not significant shifts in wind or load output within one minute (and hence not reflected in the one minute historical data).

The one minute wind and load data appears to exhibit constant ramping properties (up and down) over the one minute timeframe, suggesting that high frequency dynamics over periods less than one minute are unlikely. However, if higher resolution data becomes available, this should be analysed to confirm the validity of this approach.

Assessment of viability and costs

9. Based upon the amount of load following plant required in each year, determine the viability of the operation of the SWIS in the manner required.
10. Calculate costs of provision of load following service to the levels required
11. Investigate various methods for allocating costs of provision of load following service
12. Investigate alternative methodologies for providing load following or reducing the load following requirement, such as provision of load following service by partially curtailed wind farms (particularly during overnight low load periods).

4) GENERATION PLANTING SCENARIOS

As an outcome of Work Package 1, a total of 4 generation planning scenarios were outlined. These have been used as a basis for analysis of frequency control requirements in the SWIS for this study. The four scenarios are summarised below. The planting schedules for each scenario that were used as an input to this study are included in the Appendix (Table B.1 to Table B.4).

	Description	CPRS	Demand Growth	Gas price	CCS	Renewable technologies
1	Strained network	CPRS -15	Low	High	<i>Not available</i>	Wind
2	Minimal change	CPRS -5	Medium	Moderate	<i>Not available</i>	Wind
3	Low emissions	CPRS -25	Low	Moderate	<i>Available</i>	Mix
4	Coal development	CPRS -5	High	High	<i>Available late</i>	Wind

Table 4.2 lists the quantity of wind installed in each scenario by 2020-21, and by 2029-30.

Table 4.2 - Capacity of wind installed by scenario			
	Description	Capacity of wind installed (MW)	
		By 2020-21	By 2029-30
1	Strained network	1045	1460
2	Minimal change	488	820
3	Low emissions	744	1076
4	Coal development	620	835

Scenario 1 – Strained network

Under Scenario 1 a moderately strong CPRS (15% reduction below 2000 levels by 2020) causes relatively low investment in coal (see figure below). All installed coal plant is assumed to be “CCS ready”, in anticipation of higher emissions prices under the CPRS. The relatively high carbon price drives the retirement of Muja C in 2020-21 and Muja D in 2025-26 (they are replaced by a combination of OCGT and CCGT generation).

In general gas generation is costly due to high gas prices, but remains incentivized by the CPRS (which reduces competition from more emissions intensive alternatives). OCGTs are incentivised by the high quantity of wind installed (which provides energy but very little capacity to the reserve margin).

Figure 4.1 – Scenario 1 – Installed capacity by technology type

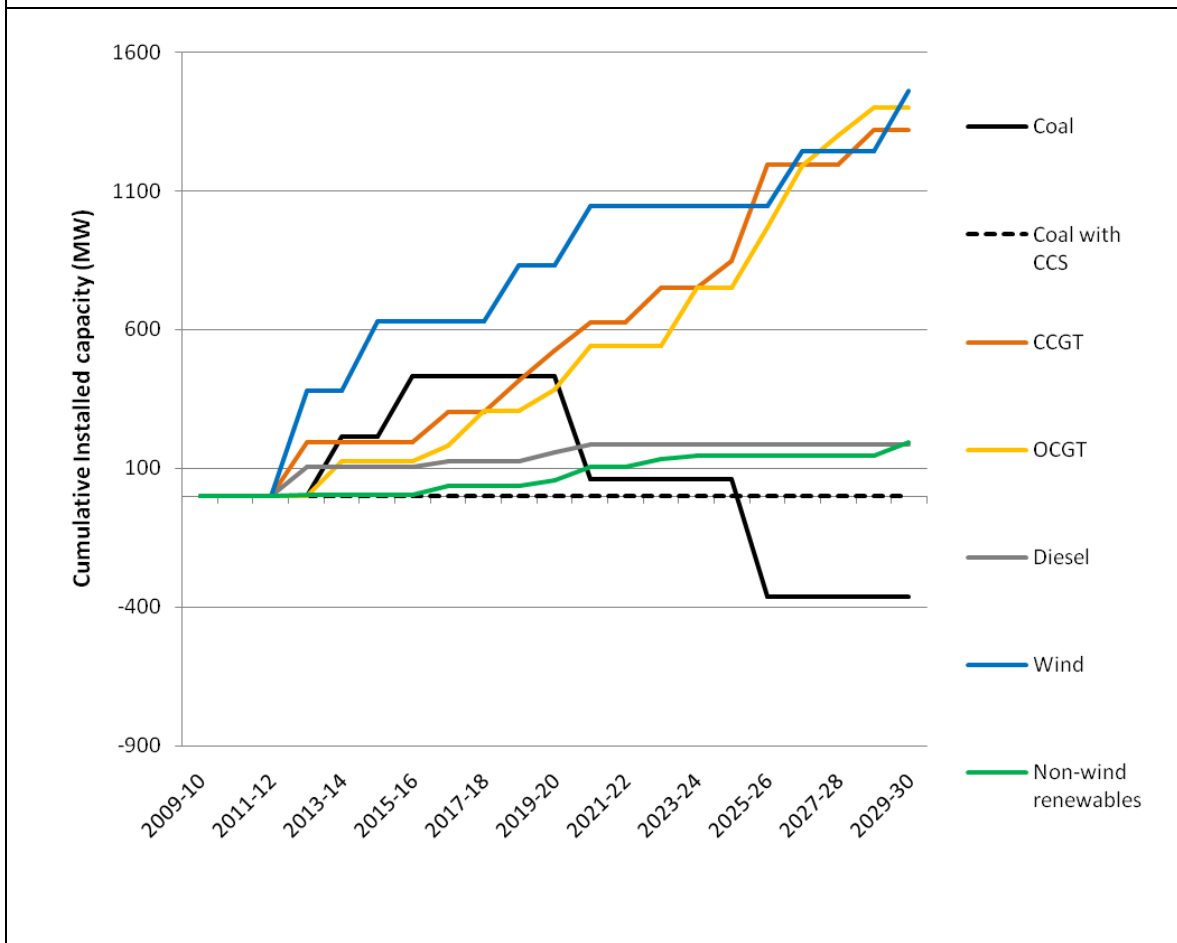

Non-wind renewable technologies develop slowly in this scenario, which drives strong investment in wind energy to meet the RET. Due to the moderately strong CPRS and high gas prices, investment in wind energy exceeds the RET from an early date.

This scenario is designed to explore an outcome where the grid will be maximally strained.

Scenario 2 – Minimal change

Under Scenario 2 the competition between coal and gas is similar to Scenario 1. Despite a much less ambitious CPRS (5% reduction below 2000 levels by 2020), gas prices are lower, allowing a mixture of gas and coal generation to be installed (see figure below).

Figure 4.2 – Scenario 2 – Installed capacity by technology type

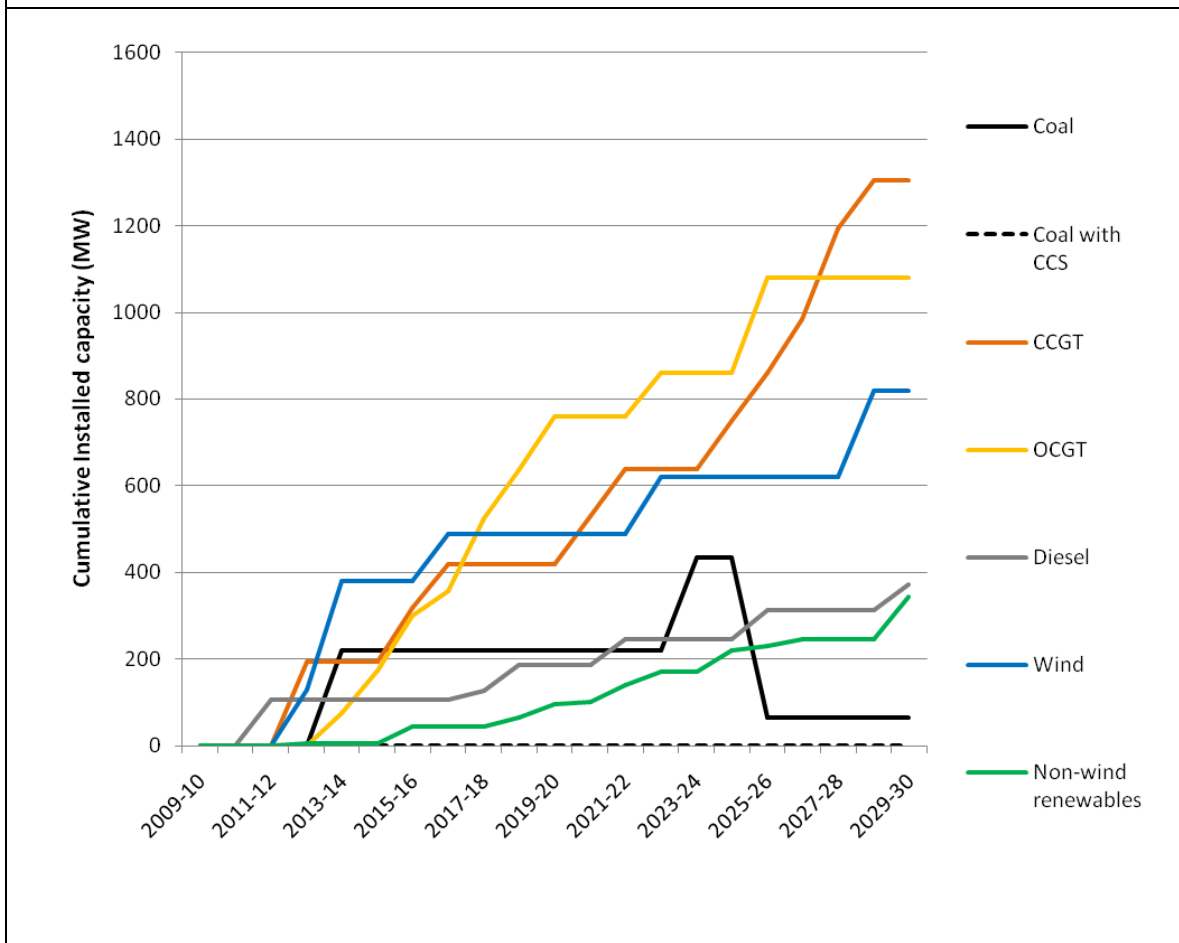

The unambitious CPRS in this scenario causes a relatively low level of investment in renewable technologies, with the SWIS only just achieving its share of the RET. Due to lack of incentives the less mature renewable technologies (non-wind) develop slowly and only minor pilot projects in various technologies are installed. Therefore the majority of the RET is met by wind.

Banking of renewable energy certificates is permissible under the RET, incentivising overshoot of the annual targets in the early years of the scheme, and allowing underachievement of targets in the following years.

Scenario 3 – Low emissions

In Scenario 3 the very ambitious CPRS (25% reduction below 2000 levels by 2020) excludes the possibility of installing coal plant without CCS technology (see figure below). A pilot 100MW CCS coal plant is installed in 2020, and a larger 400 MW plant several years later in 2023-24.

The very high carbon price drives the retirement of Muja C in 2016-17, when sufficient replacement capacity (in the form of CCGTs) becomes available and undercuts its operation. Muja D similarly retires in 2020-21 when the Electricity Sector Adjustment Scheme ceases to provide incentives for emissions intensive coal-fired plant to remain available to the market.

The high cost of coal technologies drives investment towards gas, further incentivised by the moderate gas prices in this scenario. Investment favours CCGTs in early years of the study due to the lack of other types of inexpensive base-load generation. In the later parts of the study OCGTs are favoured due to the abundance of renewable technologies available providing base-load generation.

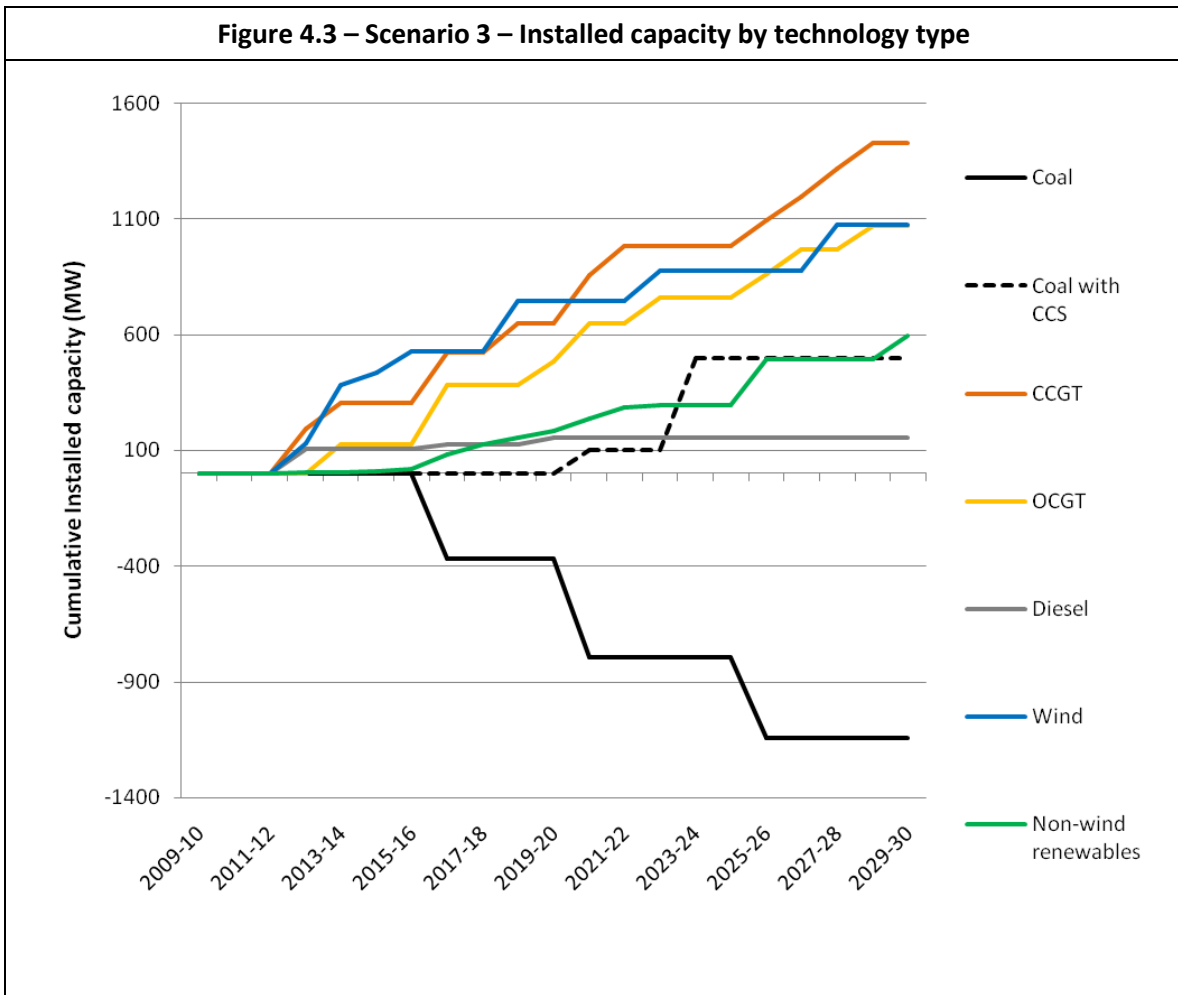

The very high carbon price allows significant investment in renewable technologies, and a wide variety of them are available from an early date. This is the only scenario where non-wind renewable technologies are present in substantial quantities, allowing 600 MW to be installed by 2030. This is accompanied by 1080 MW of wind (in 2030).

The investment in renewable technologies exceeds the RET initially due to the incentives to bank renewable energy certificates. Later, the carbon price is sufficient to incentivise renewable technologies making the RET unnecessary.

This scenario explores the maximum emissions reductions that are likely to be possible, if all measures are taken and all low carbon technologies receive substantial research and commercialization investment.

Scenario 4 – Coal development

In Scenario 4 an unambitious CPRS (5% reduction from 2000 levels by 2020) combined with high gas prices and high demand growth incentivises the installation of new coal plant, even in the absence of CCS technology. All of this installed coal-fired capacity is assumed to be “CCS ready” in anticipation of higher future emissions prices under the CPRS.

Investment in gas generation is also required to meet the very high demand growth in this scenario. CCGTs are incentivised above further development in coal in the later parts of the study as the carbon prices rises. A small CCS pilot project is available later in the study (2024-25).

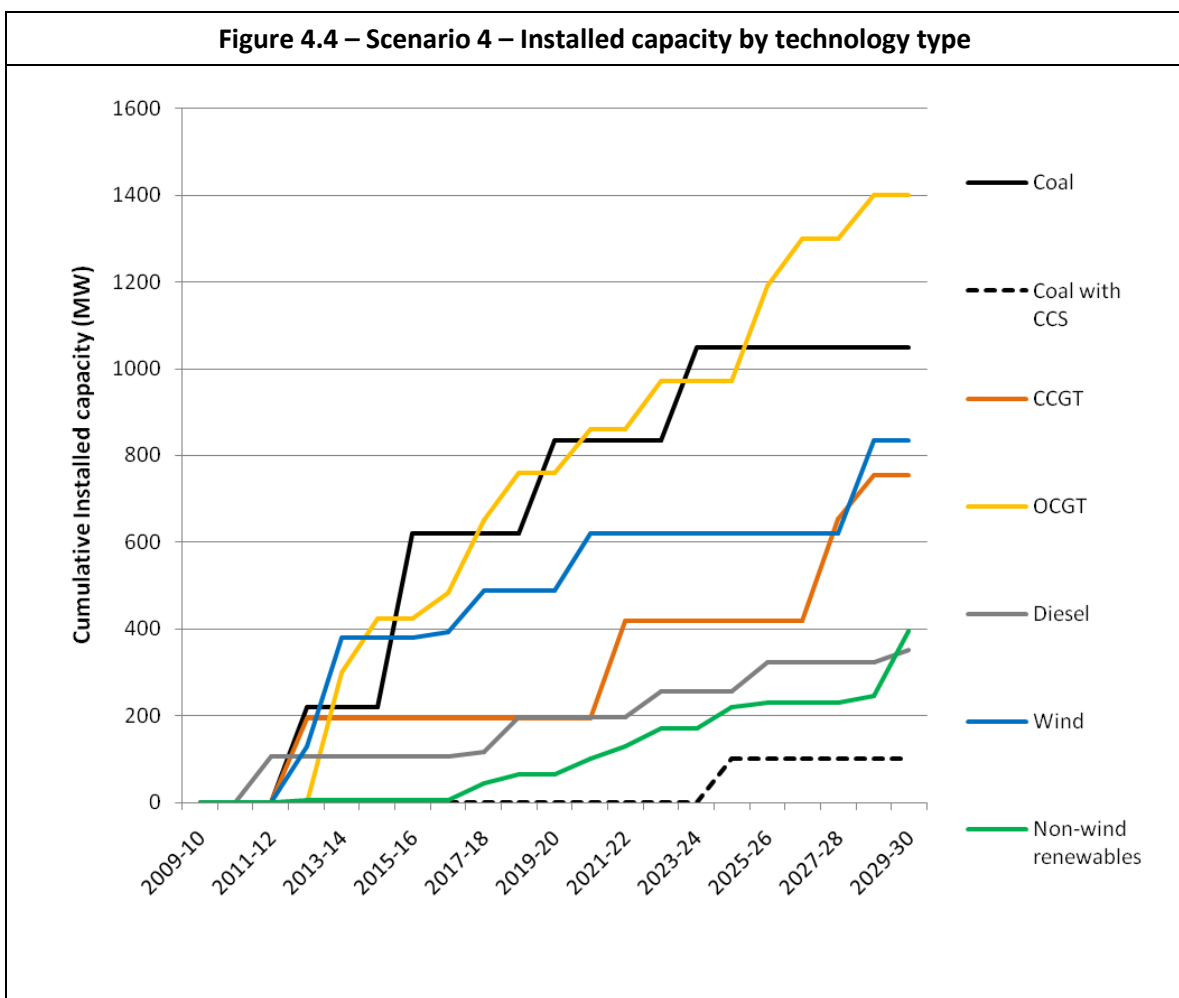

Renewable technologies are installed at a rate only just sufficient to meet the SWIS's proportionate share of the RET, with the majority in wind technology. Banking of renewable energy certificates is incentivised in the early parts of the scheme, allowing underachievement of the target in the following years.

5) METRICS FOR ASSESSING LOAD FOLLOWING REQUIREMENTS

There is no definitive methodology for assessing the amount of plant required to provide a load following service in any system. A variety of methods are used internationally. This section outlines the method currently in use in the SWIS (which is used throughout this report) in addition to an alternative method that is more comprehensive. This allows analysis of the impacts upon load following requirements outside of the timescale and magnitude of the current methodology.

This chapter outlines the theoretical basis for the equations used to calculate load following requirements. Since this chapter is very detailed, readers may choose to skip it (and perhaps read it at a later time if this level of detail is required). Later chapters of this report can be comfortably read without a detailed understanding of this section.

5.1) CURRENT METHODOLOGY

The Market Rules state:

3.10.1. *The standard for Load Following Service is a level which is sufficient to:*

- (a) *provide Minimum Frequency Keeping Capacity, where the Minimum Frequency Keeping Capacity is the greater of:*
 - a. *30 MW; and*
 - b. *the capacity sufficient to cover 99.9% of the short term fluctuations in load and output of Non-Scheduled Generators and uninstructed output fluctuations from Scheduled Generators, measured as the variance of 1 minute average readings around a thirty minute rolling average.*

This is intended to be sufficient to meet the frequency operating standards defined in the Technical Rules, which specify that the frequency in the South West Interconnected Network must be maintained between 49.8 to 50.2 Hz for 99% of the time¹⁵.

The standard for Load Following Service specified by clause 3.10.1(b) of the WEM Rules was calculated for this study as follows:

For each minute of the year, the deviation of the load and wind from their respective recent averages was calculated. Different calculations for the mean were used for each. The load was compared to its rolling half hour mean, 15 minutes either side. This implicitly assumes that the

¹⁵ In section 11.3) of this report ROAM illustrates that system frequency modelling suggests that the standard for Load Following defined in the WEM Rules is adequate and appropriate for maintaining frequency within the band required in the Technical Rules.

future load can be forecast with some degree of accuracy from the preceding 15 minute interval. As such, the load variation calculation is¹⁶:

$$\Delta L_i = L_i - \langle L_{i-15}:L_{i+15} \rangle$$

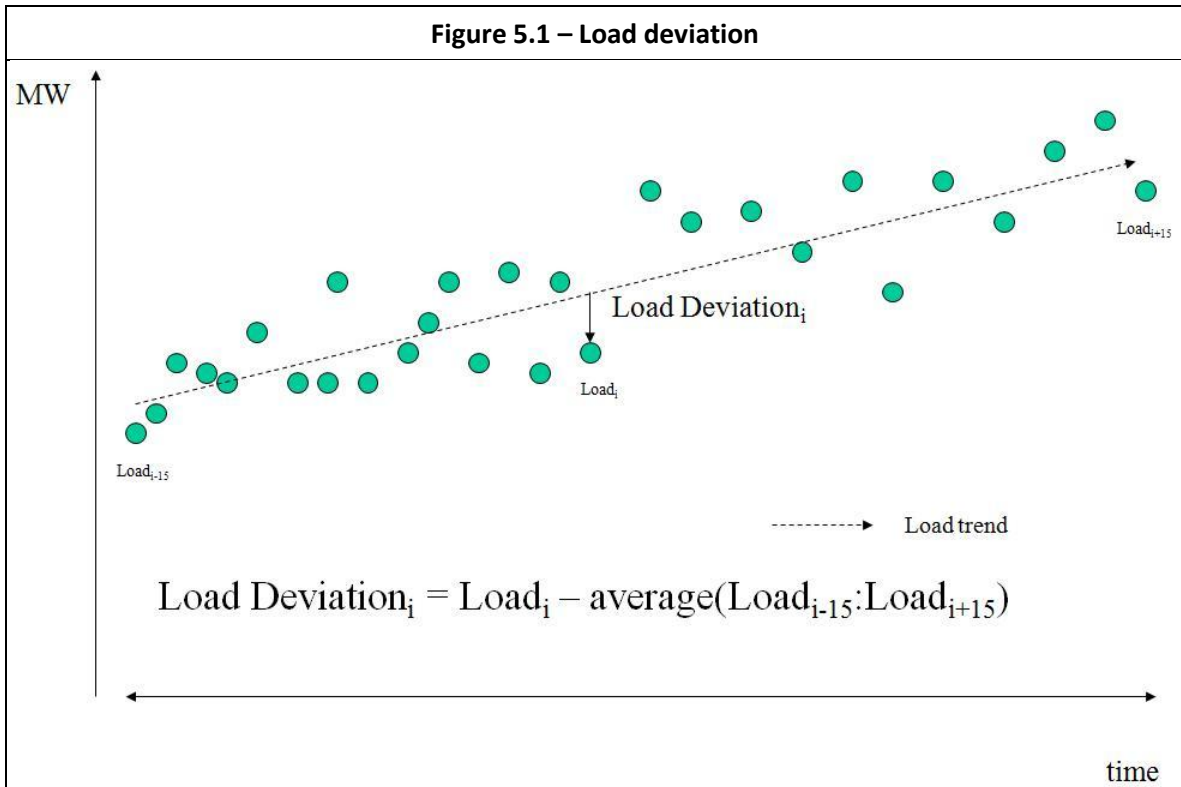

Wind speeds were compared to a rolling 30 minute average but for the preceding half hour period (i.e., a 30 minute window centred 30 minutes earlier). Wind is less predictable than load (so future forecasts are not included in the calculation) and generation will respond slower to rising average wind output. This therefore provides a more conservative approach, and load following generators may be required to respond to larger (relative) spikes in wind generation. The relevant variation in wind generation is given by:

$$\Delta W_i = W_i - \langle W_{i-45}:W_{i-15} \rangle$$

¹⁶ Throughout this report, angled brackets of the type $\langle \rangle$ indicate an average over the units contained between, from the unit to the left of the colon to those to the right of the colon. This equation therefore says that to calculate the load variation at time i (ΔL_i), take the difference between the load at time i (L_i) and the average of the load over the 30 minutes around that point, from the load 15 minutes ago at time $i-15$ (L_{i-15}) to the load 15 minutes ahead at time $i+15$ (L_{i+15}).

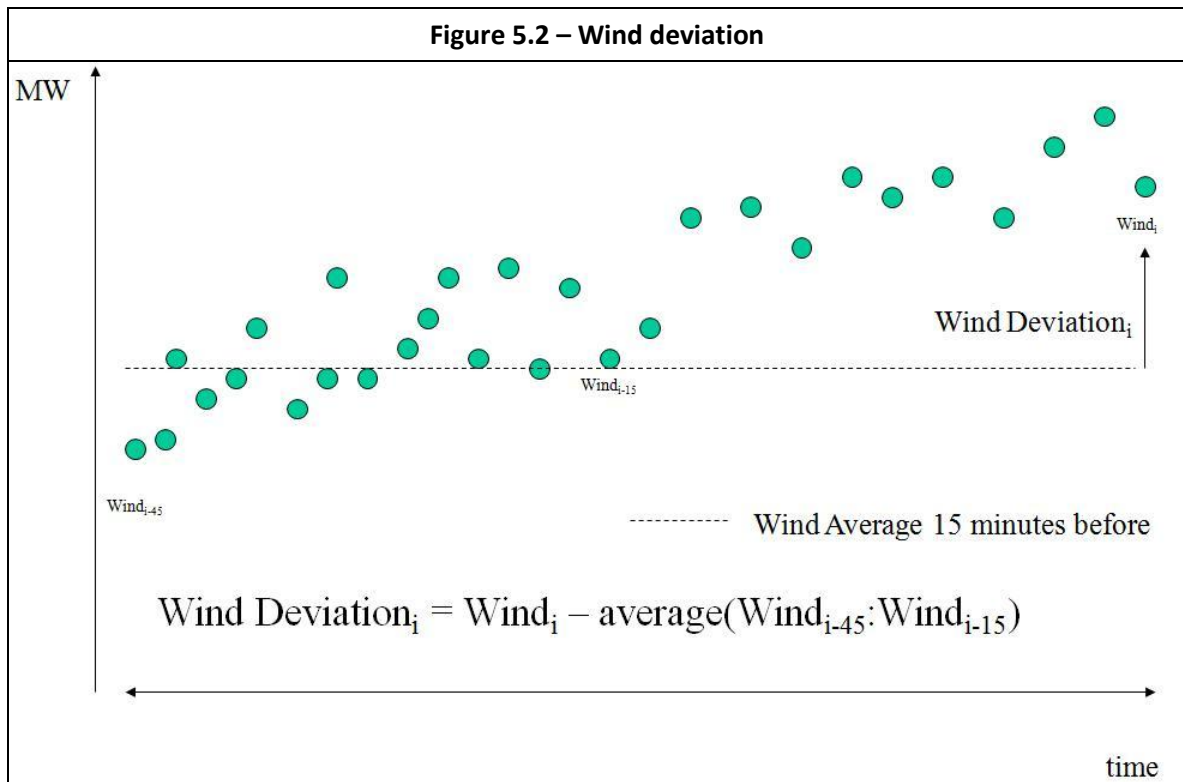

The deviations that load following generators must respond to is given by the change in scheduled generation (S), which is the load net of the wind:

$$S_i = L_i - W_i$$

$$\Delta S_i = \Delta L_i - \Delta W_i$$

ROAM then calculated the required load following capacity to cover 99.9% of all periods, as per the Rules.

Determination of ramp rate requirement

In addition to defining a quantity of plant required for load following in each year (the Load Following Requirement), that plant must be able to provide a sufficient ramp rate (MW/min). The ramp rate required of the aggregated load following plant is determined as follows.

For each minute i :

$$S_i = L_i - W_i$$

$$\Delta S_i = S_i - S_{i-5}$$

The required ramp rate is the 99.0% percentile (that is 0.5% and 99.5% percentile) of the 5 minute scheduled generation change (ΔS_i) (in MW/5min). The ramp rate is expressed in MW/min, being the 5 minute scheduled generation change divided by 5 ($\Delta S_i/5$).

This quantity is not expressed in the market rules so the concepts of rolling average and 99.9% are not required.

5.2) PROPOSED ALTERNATE METHODOLOGY

ROAM has utilised the current methodology for calculating the required load following service, but recognises that this methodology may not be accurate and directly applicable for very high levels of penetration of intermittent generation. Therefore, in addition to calculating the load following requirement utilising the current methodology, ROAM has taken a first principles approach to analyse in detail the various components of this service that will need to be provided.

The load following requirement has three components which each must be satisfied to provide continuous frequency stability. These are outlined in the table below. More detailed explanations of the methodology for calculating each component are provided below. ROAM has calculated all of these components for the projected wind and demand to 2030.

The Fast Response component is particularly important, since this connects the load following standards defined via this variance method to the frequency operating standards defined in the Technical Rules (which specify that the frequency in the South West Interconnected Network must be maintained between 49.8 to 50.2 Hz for 99% of the time). In section 11.3) of this report ROAM illustrates that system frequency modelling of the Fast Response component defined here suggests that the standard for Load Following defined in the WEM Rules is adequate and appropriate for maintaining frequency within the band required in the Technical Rules.

Definitions:

L_i	=	Load at time i
W_i	=	Wind at time i
$L_{E,i}$	=	Expected load at time i
$W_{E,i}$	=	Expected wind at time i
ΔS_i	=	Capacity of Slow following plant required for load following (slow response)
ΔR_i	=	Capacity of Regulation plant required for load following (intermediate response)
ΔF_i	=	Capacity of Fast response plant required for load following (fast response)
ΔC_i	=	Load following requirement, as currently defined by System Management

Type	Relevant timeframe	How it is provided	How to calculate it
Slow	5min -	Continuous slow	Maximum of the difference between the

Type	Relevant timeframe	How it is provided	How to calculate it
Following (S)	60min	and coarse grained variation within an hour Could be provided through AGC (Automatic Generation Control) or through slower contact with System Management (eg. phone)	level at which most plant are dispatched each 60min, and the rolling 30min average. $\Delta S_{i+} = \max_{j=1:60} [(L_{E,i+j} - W_{E,i+j}) - (L_{E,i+30} - W_{E,i})]$ $\Delta S_{i-} = \min_{j=1:60} [(L_{E,i+j} - W_{E,i+j}) - (L_{E,i+30} - W_{E,i})]$ $L_{E,i} = \langle L_{i-15}: L_{i+15} \rangle$ $W_{E,i} = \langle W_{i-30}: W_{i-1} \rangle$ Determine 99.95th percentile of negative and positive deviations.
Regulation (R)	1min - 5min	AGC response - pulsed signal from system management to increase or decrease output each minute. Provides minute to minute deviations from 5min dispatch.	Difference between actual load and wind and their rolling 30min average. $\Delta R_i = [L_i - \langle L_{i-15}: L_{i+15} \rangle] - [W_i - \langle W_{i-30}: W_{i-1} \rangle]$ Calculate positive and negative deviations, and determine 99.95th percentile of each.
Fast response (F)	< 1min	Governor response, system inertia	Minute to minute variations in the load and wind. $\Delta F_i = (L_i - W_i) - (L_{i-1} - W_{i-1})$ Calculate positive and negative deviations, and determine 99.5th percentile of each.

All parameters have been calculated for three separate cases:

- Deviations due to wind and demand combined
- Deviations due to wind alone
- Deviations due to load alone

5.3) SLOW FOLLOWING SERVICE

Expected wind at time i is calculated as the rolling average of the previous 30 minutes:

$$W_{E,i} = \langle W_{i-30}:W_{i-1} \rangle$$

Expected load at time i is calculated as the rolling average of the current 30 minutes. This assumes we can accurately forecast the load in the next 15mins.

$$L_{E,i} = \langle L_{i-15}:L_{i+15} \rangle$$

All plant in the system will be dispatched at time i for the following 60 minutes to this level:

$$60\text{min Dispatch}_i = L_{E,i+30} - W_{E,i}$$

Note that not all plant will be re-dispatched every 60 minutes. For example, large thermal plant will likely remain dispatched to maximum capacity throughout the day, reducing to minimum loads overnight. These plant will experience a re-dispatch only several times a day. This 60 minute dispatch level refers to the intermediate plant in the system that is marginal and can vary output on an hourly basis. It is assumed that any plant that must vary output on a timescale shorter than one hour is providing a load following service which must be accounted for in this metric. Note that this service is not currently accounted for in the current load following service definition, but could become significant with high levels of penetration of intermittent generation.

The capacity of slow following plant required is calculated as the maximum of the difference between the rolling average at time $i+j$ (where j is between 1 and 60 minutes) and the 60 minute dispatch level at time i :

$$\Delta S_i = \max_{j=1:60} [(L_{E,i+j} - W_{E,i+j}) - 60 \text{ min Dispatch}_i]$$

$$\Delta S_i = \max_{j=1:60} [(L_{E,i+j} - W_{E,i+j}) - (L_{E,i+30} - W_{E,i})]$$

$$\Delta S_i = \max_{j=1:60} [\langle L_{i+j-15}:L_{i+j+15} \rangle - \langle W_{i+j-30}:W_{i+j-1} \rangle - \langle L_{i+15}:L_{i+45} \rangle + \langle W_{i-30}:W_{i-1} \rangle]$$

Since we must calculate positive and negative deviations:

$$\Delta S_{i+} = \max_{j=1:60} [\langle L_{i+j-15}:L_{i+j+15} \rangle - \langle W_{i+j-30}:W_{i+j-1} \rangle - \langle L_{i+15}:L_{i+45} \rangle + \langle W_{i-30}:W_{i-1} \rangle]$$

$$\Delta S_{i-} = \min_{j=1:60} [\langle L_{i+j-15}:L_{i+j+15} \rangle - \langle W_{i+j-30}:W_{i+j-1} \rangle - \langle L_{i+15}:L_{i+45} \rangle + \langle W_{i-30}:W_{i-1} \rangle]$$

5.4) REGULATION SERVICE

Capacity of plant required for regulation is calculated as the difference between the actual load and wind at time i and the expected load and wind at time i .

$$\Delta R_i = (L_i - W_i) - (L_{E,i} - W_{E,i})$$

$$\Delta R_i = (L_i - W_i) - [\langle L_{i-15}: L_{i+15} \rangle - \langle W_{i-30}: W_{i-1} \rangle]$$

$$\Delta R_i = [L_i - \langle L_{i-15}: L_{i+15} \rangle] - [W_i - \langle W_{i-30}: W_{i-1} \rangle]$$

This is very similar to the methodology used currently by System Management in calculating the load following. In the current methodology a 15 minute delay is used for the calculation of the expected wind (expected wind is calculated from the average wind from time $i-45$ to $i-15$). In this methodology ROAM utilises wind data from the previous 30 minutes (average wind from time $i-30$ to $i-1$).

5.5) FAST RESPONSE SERVICE

To determine the required fast response service, calculate the one minute shifts in load (L_i) net of wind (W_i).

$$\Delta F_i = (L_i - W_i) - (L_{i-1} - W_{i-1})$$

Discard largest 1% (99th percentile¹⁷). This is then used as an input to the system frequency model to determine amount of inertia and governor response required to keep frequency within 49.8 to 50.2 Hz.

5.6) ILLUSTRATIVE EXAMPLE OF ALTERNATE METHODOLOGY

An illustrative example is shown in the following figures, where a particular 5hr period is shown with an assumed point of dispatch. Under the methodology described above every possible point of dispatch is considered, and the maximum determined for each time i (this is difficult to illustrate graphically, so has not been shown in the figures below). The figures in this section are intended to be purely illustrative of the concepts; data from all periods was analysed for a complete understanding of the functioning of these proposed metrics.

Figure 5.3 shows the load net of wind (blue) with the 60 minute dispatch levels that would result each half hour, based upon the above stated method for calculating the "expected" wind and load in any future half hour. The slow following service smooths this 60 minute dispatch by gradually ramping up and down as required. Note that only a slow ramp is required, and the fast variations remain to be covered by the faster load following services (regulation and fast response).

The response of the slow following service is delayed from changes in the load-wind due to the calculation of the expected wind from the previous half hour.

¹⁷ The 99th percentile has been used here since the frequency standard in the Rules states that frequency must be maintained within the required limits for 99% of the time. By contrast, the load following requirement is defined based upon a 99.9th percentile of the variance of load/wind deviations.

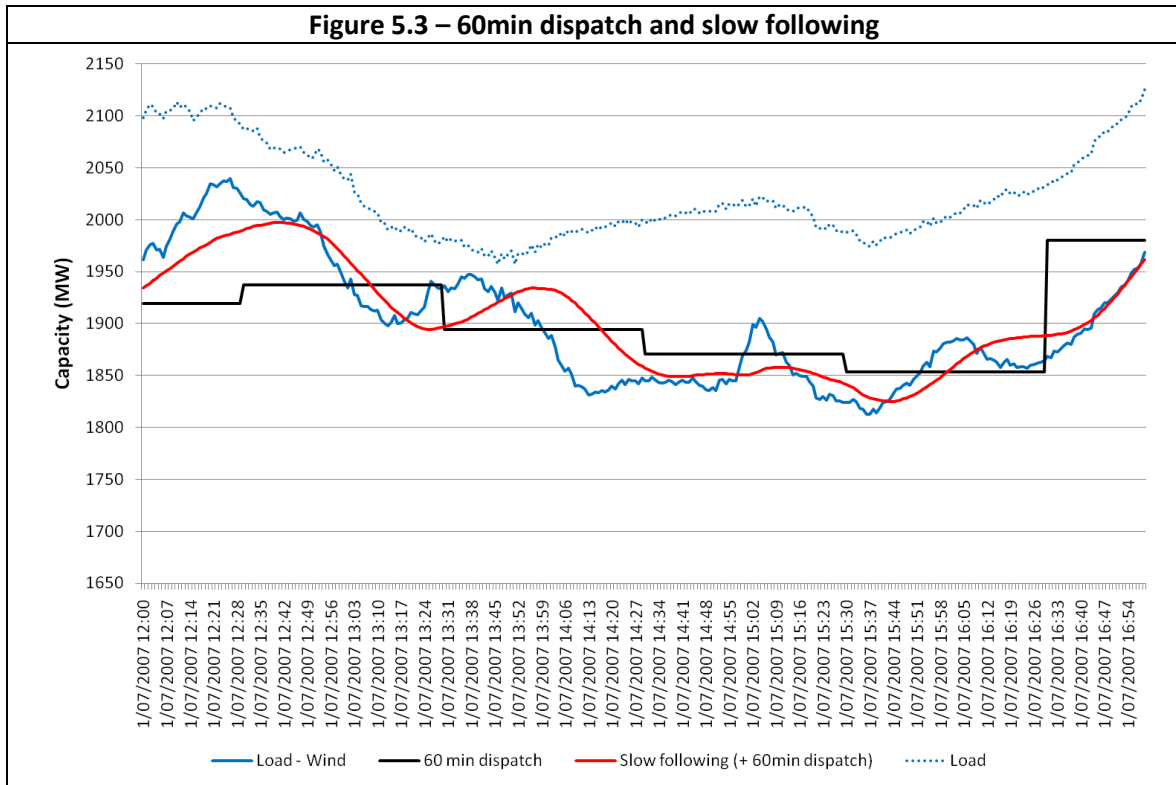

Figure 5.4 shows the actual ramping of the plant providing the slow following service. Sharp edges are observed where the 60 minute re-dispatch occurs. In reality this plant would not need to provide an instantaneous ramp - other plant in the 60min dispatch would ramp slowly to their new positions, and the load following plant providing the slow following service could ramp correspondingly slowly.

Figure 5.4 also shows the actual ramping of the plant providing the regulation service. Faster minute to minute changes are required than for the slow following service.

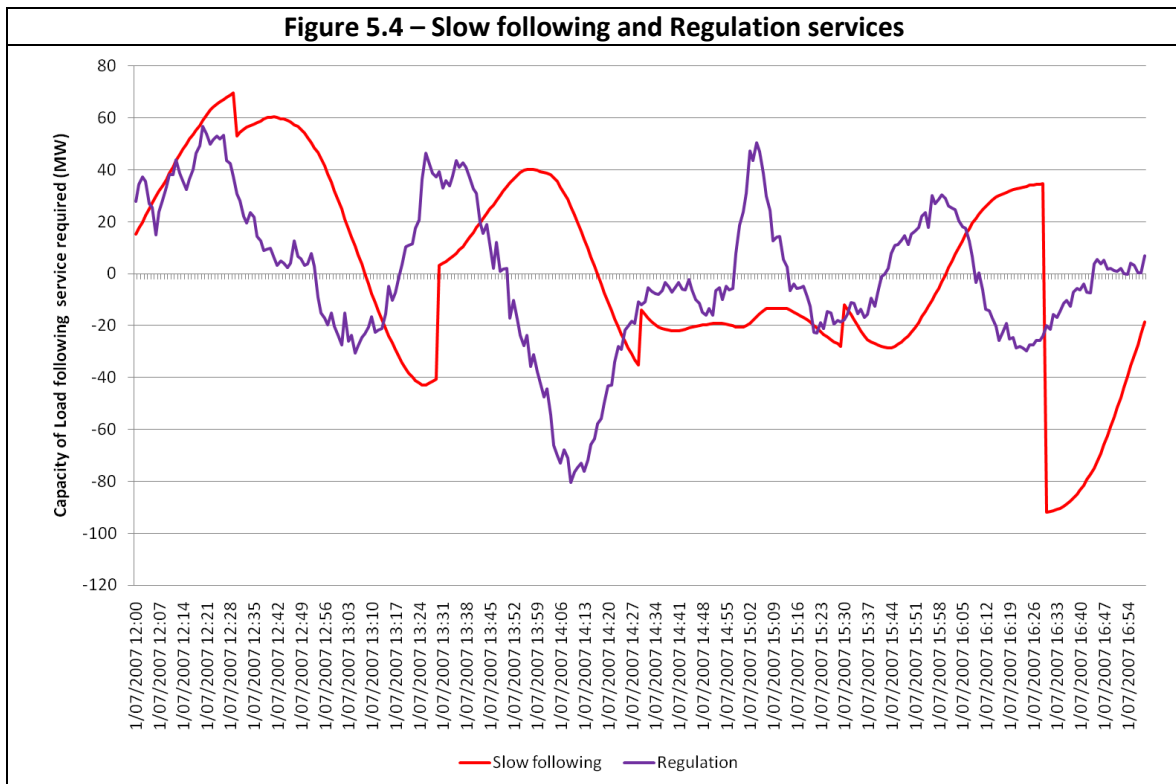

Figure 5.5 shows the fast response (minute to minute) variations that would be dealt with through the Fast response service (governor and inertia response). These are very short timeframe, but smaller in magnitude.

Figure 5.6 and Figure 5.7 show the same charts over a different period where wind farm output is relatively constant, but load is varying considerably. A much larger quantity of slow following service is required to consistently meet the rapidly changing load, but the regulation service requirement is lower (due to the relatively constant wind farm output).

Figure 5.5 – Fast response service

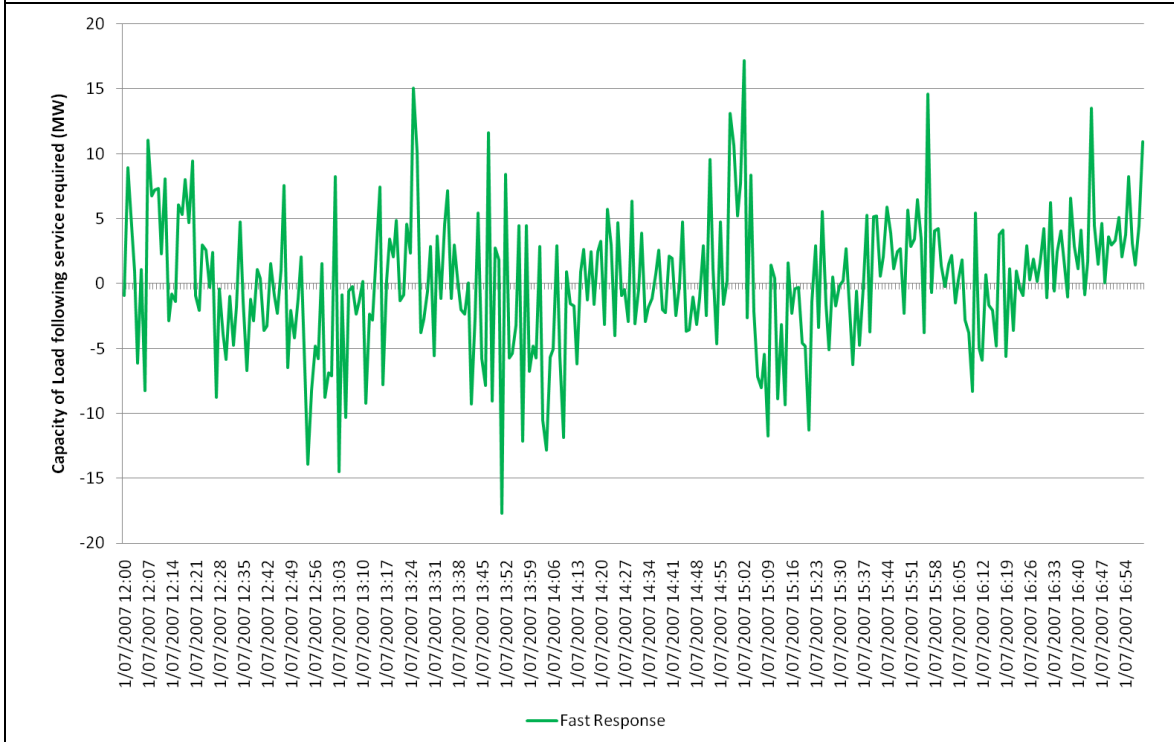

Figure 5.6 – 60min dispatch and slow following (constant wind)

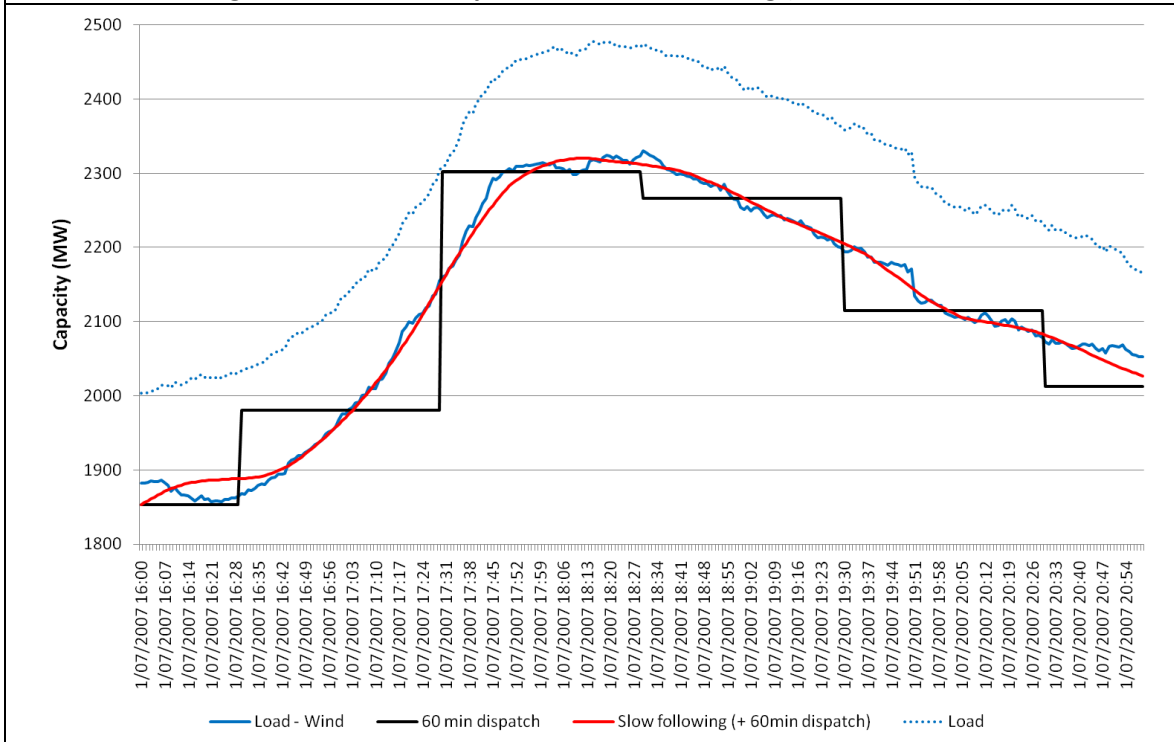
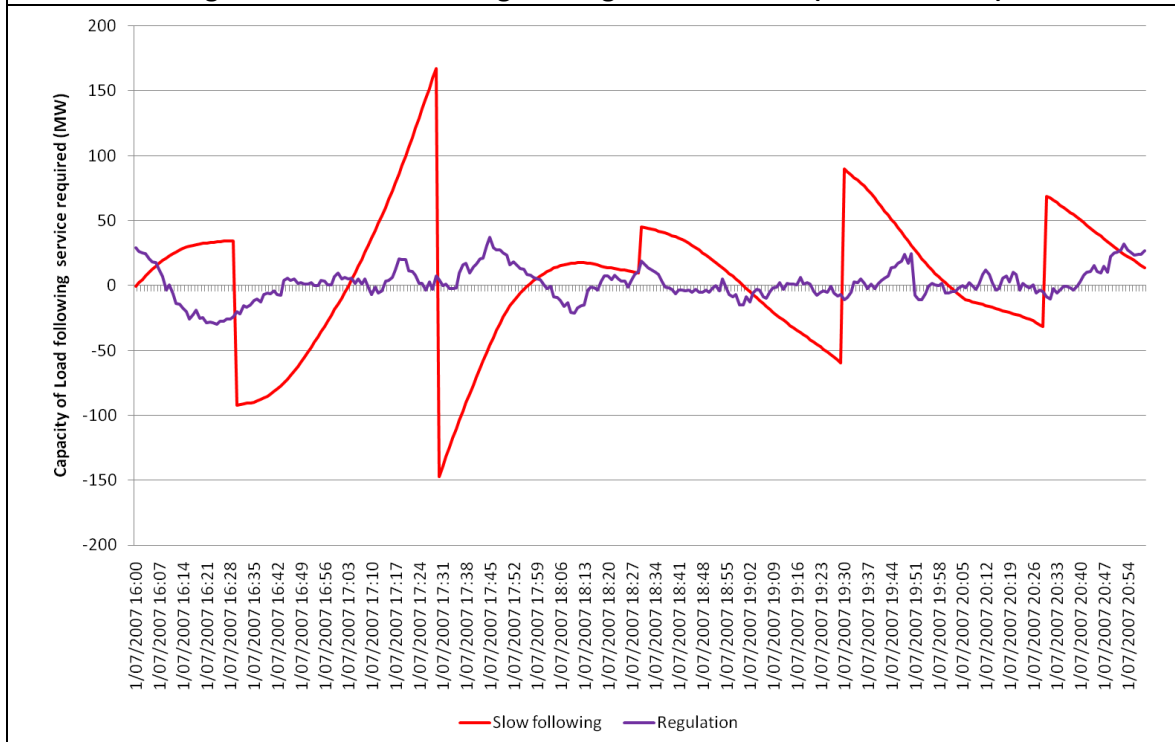

Figure 5.7 – Slow following and Regulation services (constant wind)



6) WIND AND DEMAND MODELLING

6.1) WIND ENERGY SIMULATION TOOL (WEST)

The outputs of new wind farms at new locations were forecast utilising ROAM's WEST software.

WEST (ROAM's proprietary Wind Energy Simulation Tool) calculates generation traces for wind farms based on historical data from the Bureau of Meteorology, location specific wind speed simulations from the Australian Renewables Atlas and manufacturer provided turbine power curves. These are routinely used as input to ROAM's electricity market models for explicit modelling of wind farm generation and transmission congestion with high quantities of renewable energy.

WEST requires as input the average wind speed at the wind farm site for each one minute period. Historical data is sourced from automatic weather stations around Australia from the Bureau of Meteorology.

The wind data from the Bureau of Meteorology (BOM) weather stations is taken at a variety of elevations (from 1m off the ground to 70m above the ground), and elevation strongly affects wind speeds. The wind at the height of a turbine hub (from 50m to 80m) will be much faster than the wind at ground level, and the amount of the increase in speed is strongly dependent upon many factors, including the type of ground cover (rock, grass, shrubs, trees) and the nature of the

weather pattern causing the wind. In addition, the local topography affects wind speeds very strongly (winds tend to be focused by flowing up hillsides, for example).

However, it is reasonable to assume that the wind speeds at the weather station will be highly correlated in time with the wind speeds at the turbine site (analysis of existing wind farm generation profiles compared with the BOM weather station data shows this to be the case, as illustrated in the figures below).

To provide the absolute scaling, ROAM uses data from the Renewable Energy Atlas of Australia¹⁸. The Atlas contains modelling data provided by Windlab Systems giving the mean annual wind speeds, at a typical turbine height of 80m, at 3km resolution for most of Australia. The mean wind speed at the wind farm site is used to scale the data from the closest weather station to provide an estimate of the wind speed time series at turbine height.

Finally, the wind speeds are adjusted (reduced) to account for turbulence and shading across the wind farm (the “park effect”), calibrated by historical generation from existing wind farms and historical wind speeds from the BOM. For this study, this calibration was performed using the provided wind farm outputs from Emu Downs, Walkaway and Albany.

ROAM’s WEST program then applies a turbine power curve to convert the wind speeds into actual generation for input into 2-4-C, ROAM’s market dispatch system, or for other modelling purposes (this accounts for the fact that the efficiency of turbines varies strongly with wind speed).

As a final check, the annual time of day average generation is compared to historic data, and the output adjusted if necessary to achieve an appropriate time of day average generation curve. This accounts for qualitative differences between time of day wind speed distributions at hub height versus the BOM stations.

This method captures the daily and seasonal variation of wind at different sites, and also the likely correlation between the output of nearby wind farms (which is highly material for transmission congestion). ROAM is therefore able to accurately determine an aggregated wind profile for the entire SWIS, correctly taking these correlations into account.

From benchmarking exercises, ROAM is confident that this methodology produces wind generation output traces that are a good approximation for the output of wind turbines, capturing intermittency, ramp rates and capacity factors accurately.

6.1.1) Calibration of WEST

For this study, WEST was calibrated using one minute wind farm output data from Walkaway and Albany wind farms, compared with Bureau of Meteorology data from Geraldton Airport and Albany Airport.

¹⁸ <http://www.environment.gov.au/settlements/renewable/>

Time of day calibration

Due to the height of wind turbines above the ground, wind data collected at weather stations often does not accurately reproduce the correct time of day averages for wind farm outputs. Weather stations, being closer to the ground, will tend to be affected by daily wind patterns that are not experienced at a higher height. To account for this, ROAM applied a time of day weighting to the output of WEST, calibrated against the historical output of Albany wind farm and Walkaway wind farm compared with WEST output calculated at Albany Airport and Geraldton Airport.

Smoothing of wind data

Wind is typically more "gusty" than the output of a wind farm, due to the inertia of the turbines, and smoothing due to the height of the turbines above the ground. This effect is observable in one minute traces. It was therefore necessary to apply a smoothing to the output of WEST. The amount and type of smoothing was calibrated against the historical output of Albany wind farm and Walkaway wind farm compared with WEST output calculated at Albany Airport and Geraldton Airport.

The smoothing was not applied by eye, but rather was calibrated directly against the load following metrics of interest. Sufficient smoothing was applied over several timeframes to provide a match between the volatility of the WEST output and the actual wind farm output. Calibration of volatility via the load following metrics in use in this study ensures that the volatility of the resulting traces will accurately capture the expected volatility in the aggregate future wind trace (as measured via these same load following metrics).

The following smoothing was found to reproduce the load following metrics for these two sites as closely as possible:

$$W_i^S = 0.7\langle W_{i-1}:W_{i+1} \rangle + 0.3\langle W_{i-1}:W_{i-20} \rangle$$

Charts illustrating resulting typical periods are shown below for each wind farm. The wind trace calculated from the Geraldton Airport BOM data exhibits a high correlation with the output from Walkaway wind farm (0.46). Similarly the wind trace calculated from Albany Airport BOM data exhibits a high correlation with the output from Albany wind farm (0.53).

Figure 6.1 – Calibration of WEST - Albany Wind Farm

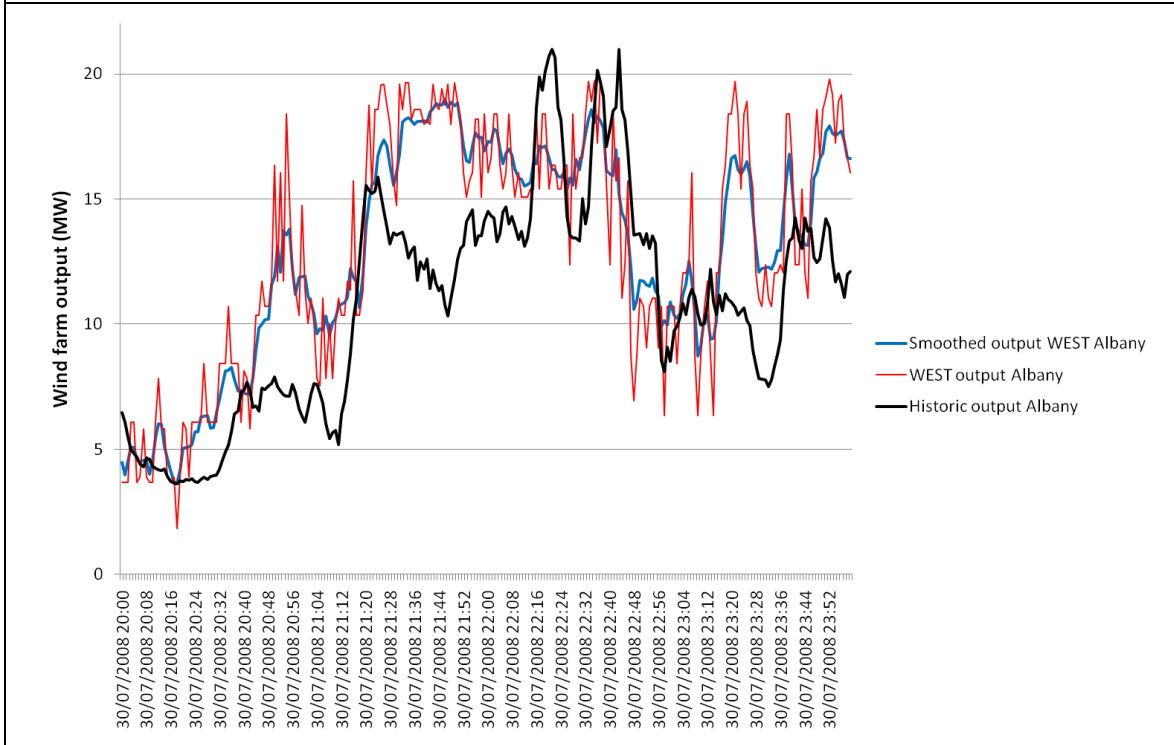
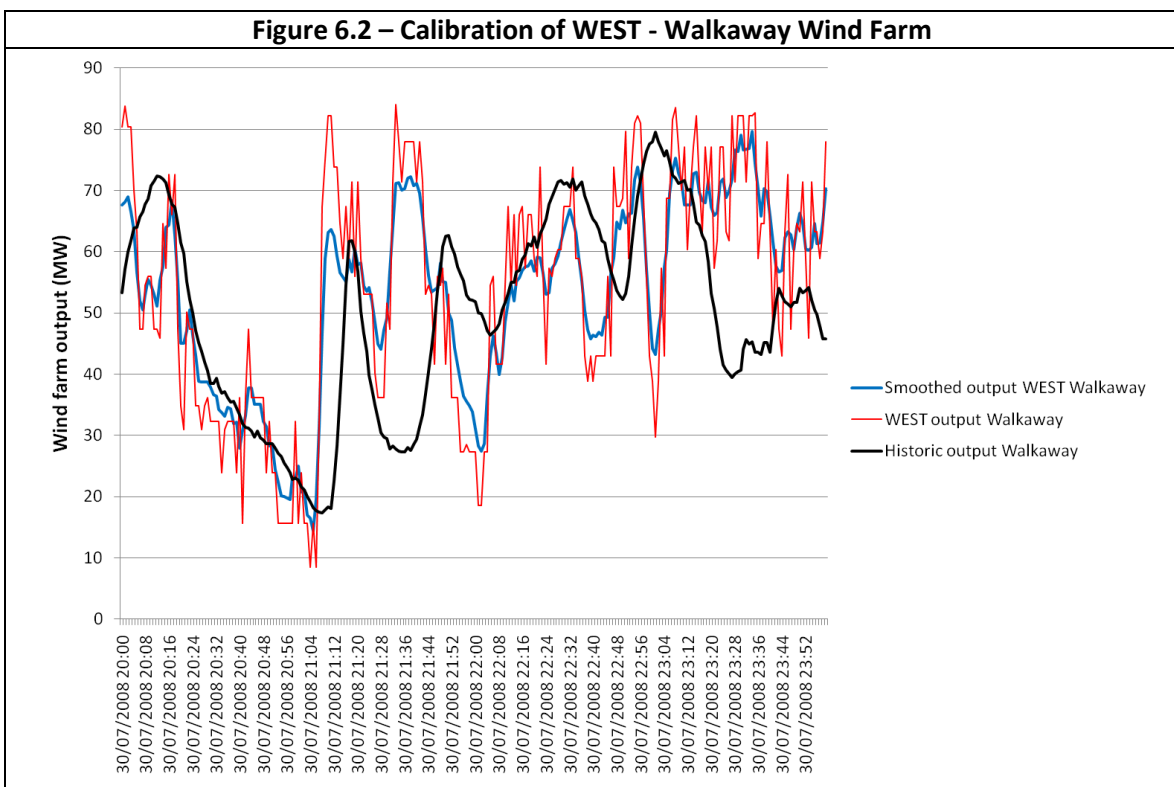

Figure 6.2 – Calibration of WEST - Walkaway Wind Farm



6.1.2) Wind farm correlations

Based upon the one minute wind data analysed in this study, weather patterns appear to be correlated within three distinct zones.

- **South area** - South coast of WA. Includes Albany wind farm.
- **North area** - North west coast of WA. Includes Walkaway wind farm, and any wind farms in the area around Geraldton. Emu Downs wind farm could be considered to be on the boundary of North area, and Perth area.
- **Perth area** - Intermediate area in-between.

Wind farms in the South area are likely to exhibit correlation with each other, but show no correlation with those in the North area. Similarly, wind farms in the North area are likely to exhibit correlation with each other, but show no correlation with those in the South area. Wind farms in the Perth area are likely to exhibit high correlation with each other, and moderate correlation with both those in the South Area and North area.

Correlation factors based upon 2008-09 one minute wind data are shown in Table 6.1.

		Table 6.1 – Correlation factors of wind data (2008-09)											
		Geraldton Airport BOM	Walkaway trace	Emu Downs trace	Pearce RAAF BOM	Perth Metro BOM	Perth Airport BOM	Bickley BOM	Mandura BOM	Dwellingup BOM	Albany Airport BOM	Albany trace	Esperance BOM
		NORTH	NORTH	NORTH / PERTH	PERTH	PERTH	PERTH	PERTH	PERTH	PERTH	SOUTH	SOUTH	SOUTH
Geraldton Airport BOM	NORTH	-	0.49	0.30	0.31	0.49	0.35	0.21	0.41	0.25	0.07	0.08	0.17
Walkaway trace	NORTH	0.49	-	0.56	0.28	0.30	0.31	0.21	0.18	0.21	-0.01	0.06	0.02
Emu Downs trace	NORTH / PERTH	0.30	0.56	-	0.44	0.32	0.43	0.38	0.15	0.31	0.03	0.05	0.01
Pearce RAAF BOM	PERTH	0.31	0.28	0.44	-	0.60	0.69	0.57	0.42	0.48	0.23	0.14	0.12
Perth Metro BOM	PERTH	0.49	0.30	0.32	0.60	-	0.67	0.45	0.60	0.41	0.21	0.15	0.23
Perth Airport BOM	PERTH	0.35	0.31	0.43	0.69	0.67	-	0.54	0.43	0.46	0.18	0.13	0.09
Bickley BOM	PERTH	0.21	0.21	0.38	0.57	0.45	0.54	-	0.34	0.60	0.22	0.07	0.10
Mandura BOM	PERTH	0.41	0.18	0.15	0.42	0.60	0.43	0.34	-	0.42	0.25	0.10	0.28

Dwellingup BOM	PERTH	0.25	0.21	0.31	0.48	0.41	0.46	0.60	0.42	-	0.22	0.06	0.15
Albany Airport BOM	SOUTH	0.07	-0.01	0.03	0.23	0.21	0.18	0.22	0.25	0.22	-	0.55	0.43
Albany trace	SOUTH	0.08	0.06	0.05	0.14	0.15	0.13	0.07	0.10	0.06	0.55	-	0.24
Esperance BOM	SOUTH	0.17	0.02	0.01	0.12	0.23	0.09	0.10	0.28	0.15	0.43	0.24	-

Geographical distribution of wind farm development to minimise generation correlation is an important way of minimising load following requirements. The collection and publishing of more detailed information on wind correlation in the SWIS is recommended, combined with appropriate incentives to developers to minimise correlations.

It is recognised that clusters of wind farms in a location where the wind is highly correlated will place additional demands on transmission and eventually restrict the ability to develop further wind plants at those locations. Such limitations could be alleviated by the construction of multiple parallel transmission corridors with wind farms distributed evenly across the parallel lines. This is an emerging feature of the South Australian grid between Port Augusta and Adelaide, and could develop in the WEM, if market conditions for wind remain favourable. This would require closer examination and may influence policies related to transmission augmentation. Such factors are now under consideration in the NEM, with the introduction of Scale Efficient Network Extensions, which provide an opportunity for transmission developments to expand into locations that are advantageous for new generation to connect.

6.2) LOAD FORECASTING

To create realistic load forecasts, ROAM utilised a proprietary load forecasting tool, the Load Trace Synthesizer (LTS). This software accepts a historical reference load trace and forecast energy and peak demand targets in order to generate load trace forecasts. With this tool, ROAM generated the required load forecast based on historic actual loads, for the “expected” 10% probability of exceedence forecast listed in the 2009 IMO Statement of Opportunities.

This tool accurately takes account of the variation in load between weekdays and weekends, public holidays, and seasonal variations, shifting the reference trace as required to accurately replicate the seven days of the week.

The model accepted and utilised as input data:

- Annual energy targets (sourced from the IMO 2009 SOO)
- Annual summer peak demand targets (sourced from the IMO 2009 SOO)
- Annual low load targets (forecast to grow at 1.5% per annum)
- 2008-09 historical load on a 1min basis (provided by System Management)

The 2008-09 year of historical demand data was used as the reference year for all future years.

6.3) CALCULATION OF LOAD FOLLOWING REQUIREMENTS

The forecast traces of load and aggregated wind for each year (calculated as described above) were analysed using the parameters outlined in Section 5). Figure 5.1 illustrates how the load deviation was calculated (separate from wind variations), and Figure 5.2 illustrates how the wind deviation was calculated (separate from load variations). The load following requirement due to variations in load and wind combined is determined by calculating a trace of "schedulable generation" by subtracting the wind from the load at each point in time. The load following requirement is then calculated as outlined in section 5.1).

Throughout this report ROAM will refer to these three parameters:

1. Load following requirement due to variations in load only. This is calculated as if the wind output was constant in all time periods.
2. Load following requirement due to variations in wind only. This is calculated as if the load was constant in all time periods.
3. Total load following requirement due to variations in load and wind. This is calculated by subtracting the wind from the load at each time i to create a trace of "schedulable generation". The load following requirement can then be calculated from this trace as outlined above.

These have been calculated for the load following requirement as calculated via the existing methodology, in addition to the requirements calculated for slow following, regulation and fast response metrics, according to the methodology outlined in section 5.2).

7) LOAD FOLLOWING REQUIREMENTS - RESULTS

7.1) EXISTING LOAD FOLLOWING DEFINITION

Table 7.1 lists the load following requirement in each year, calculated according to the existing definition. Requirements in 2009-10 are consistent with those calculated by System Management. This data is illustrated graphically in Figure 7.1.

	Scenario 1		Scenario 2		Scenario 3		Scenario 4	
	Max	Min	Max	Min	Max	Min	Max	Min
2009-10	65	-66	65	-66	65	-66	65	-67
2010-11	66	-68	67	-68	66	-68	67	-69
2011-12	72	-72	72	-72	72	-72	71	-72
2012-13	133	-141	99	-102	99	-103	99	-103
2013-14	134	-141	134	-142	134	-141	134	-142
2014-15	232	-249	134	-142	138	-143	135	-142
2015-16	233	-250	135	-142	151	-151	135	-143
2016-17	234	-250	150	-150	152	-152	137	-144

2017-18	235	-251	151	-151	153	-152	151	-151
2018-19	245	-254	152	-151	183	-188	152	-152
2019-20	245	-255	154	-152	184	-188	153	-153
2020-21	256	-276	155	-153	185	-189	162	-166
2021-22	257	-276	156	-154	186	-189	164	-167
2022-23	258	-277	165	-166	198	-193	164	-168
2023-24	259	-277	166	-168	199	-194	166	-169
2024-25	260	-278	168	-168	200	-194	167	-169
2025-26	261	-278	169	-169	202	-195	168	-169
2026-27	270	-288	171	-170	204	-195	169	-170
2027-28	272	-289	173	-171	239	-236	171	-170
2028-29	273	-289	216	-217	240	-237	200	-196
2029-30	296	-299	217	-218	242	-237	201	-198
2030-31	297	-300	218	-218	243	-238	203	-199

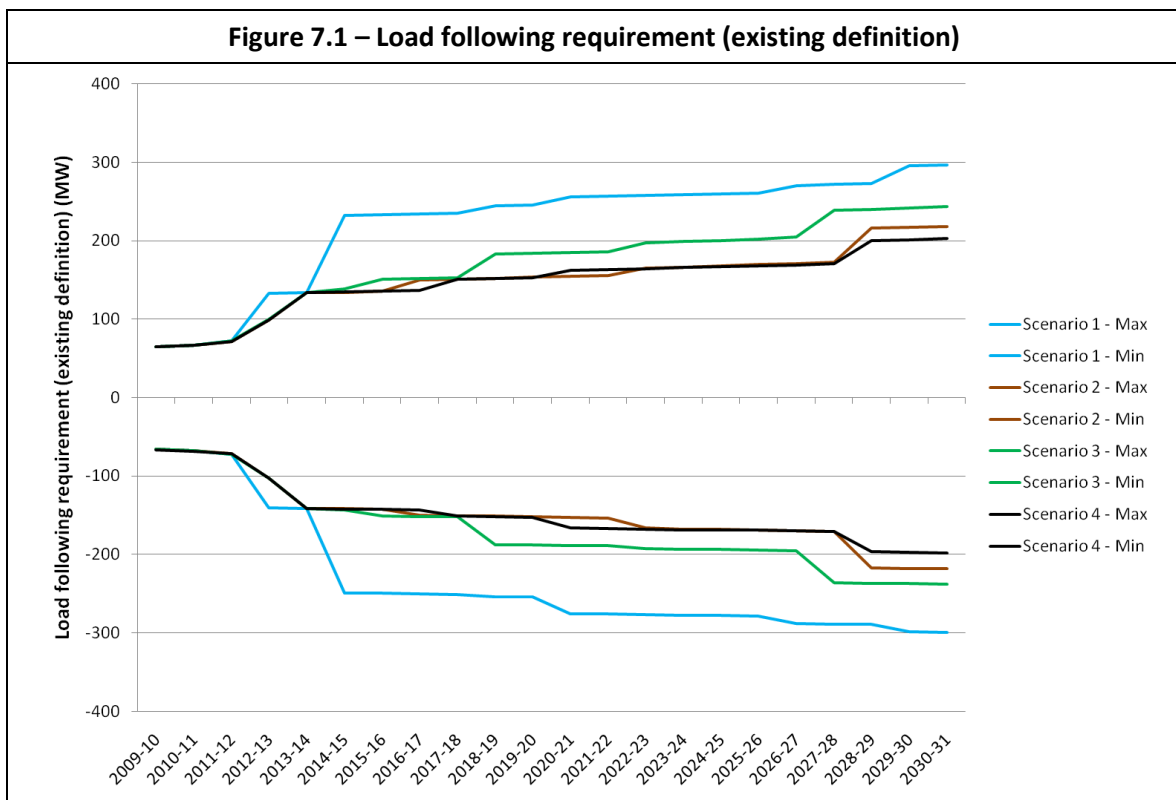

Figure 7.2 compares the load following requirement with the quantity of installed wind in each year. The load following requirement increases as the penetration of wind increases, but is also dependent upon other factors (such as the location of the installed wind, and the demand growth). Scenario 1 exhibits the largest load following requirement, due to having the largest quantity of installed wind.

The load following requirement increases by 5-40% of the capacity of a new installed

wind farm, depending upon the location of the new wind farm (and its correlation with others previously installed). On average, 14% of the capacity of the new wind farm is added to the load following requirement.

An example of interest is the installation of Collgar wind farm in 2012-13 or 2013-14. This 250 MW wind farm increases the load following requirement by 35 MW. Note that this is significantly less than the contribution of Collgar wind farm to the load following requirement recently assumed for ancillary services cost calibration studies¹⁹.

Figure 7.2 – Load following requirement (existing definition) compared with wind installation

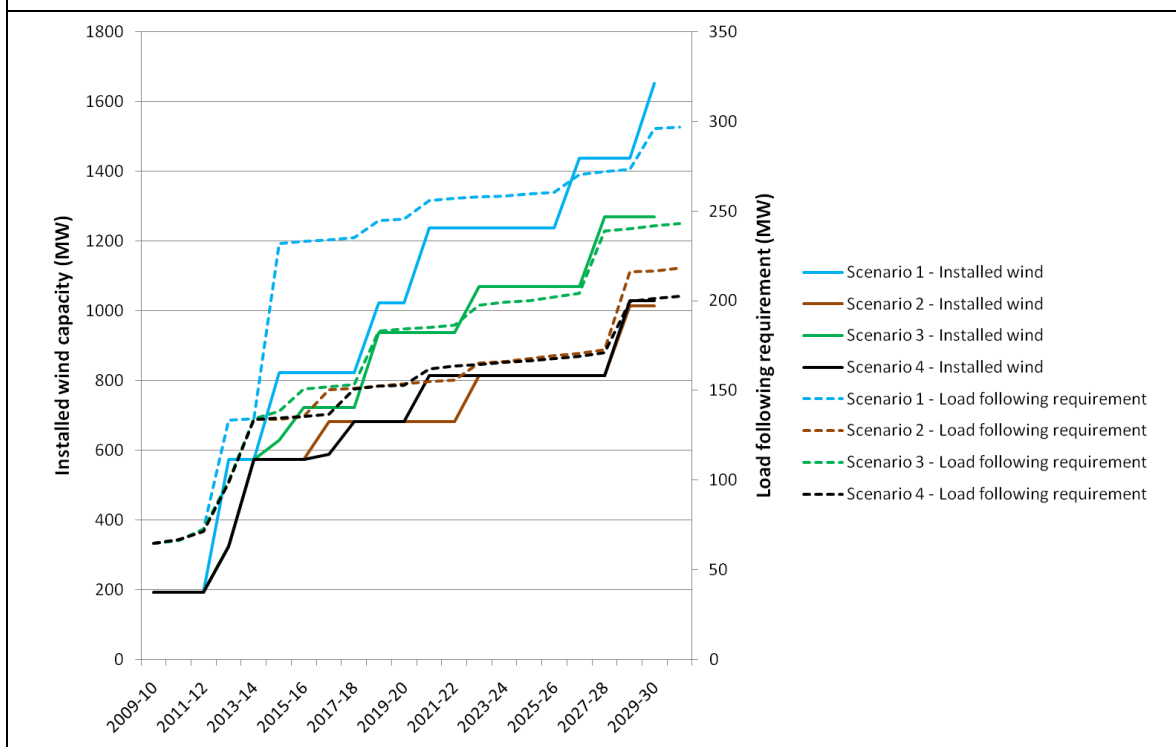

The load following requirement was calculated based upon the variation in the load alone (in the absence of wind), and based upon the variation in the wind alone (in the absence of demand variations). The load following requirements in each case for Scenario 1 are listed in Table 7.2, and shown graphically in Figure 7.3.

While there is a gradual increase in the load following requirement due to the load, there is a much larger increase due to the variation in the wind.

¹⁹ Report to Independent Market Operator of Western Australia, 2009 Margin_Peak and Margin_Off-Peak review, Final Report v4.0, 10 December 2009, MMA. Contribution of Collgar to the load following requirement is assumed to be 90 MW (increase in load following requirement from 60 MW to 150 MW upon entry of Collgar).

Interestingly, in the positive direction, the load and wind exhibit a mild anti-correlation²⁰, meaning that the load following requirement of the load and wind combined is less than that for the wind alone. This is not the case in the negative direction.

Table 7.2 - Forecast Load following requirement - Existing definition - Scenario 1

	Load and Wind		Load only		Wind only	
	Max	Min	Max	Min	Max	Min
2009-10	65	-66	50	-47	55	-49
2010-11	66	-68	53	-50	55	-49
2011-12	72	-72	64	-60	55	-49
2012-13	133	-141	67	-62	136	-126
2013-14	134	-141	70	-66	136	-126
2014-15	232	-249	71	-67	246	-225
2015-16	233	-250	78	-72	246	-225
2016-17	234	-250	81	-75	246	-225
2017-18	235	-251	85	-79	246	-225
2018-19	245	-254	90	-82	250	-236
2019-20	245	-255	94	-86	250	-236
2020-21	256	-276	97	-89	271	-244
2021-22	257	-276	101	-92	271	-244
2022-23	258	-277	105	-95	271	-244
2023-24	259	-277	110	-99	271	-244
2024-25	260	-278	114	-102	271	-244
2025-26	261	-278	118	-106	271	-244
2026-27	270	-288	122	-109	283	-251
2027-28	272	-289	125	-114	283	-251
2028-29	273	-289	129	-117	283	-251
2029-30	296	-299	133	-120	294	-277
2030-31	297	-300	137	-124	294	-277

²⁰ Anti-correlation here is simply intended to mean that the wind and demand move in such a way as to minimise the load following requirement, because "correlation" has previously been used to describe correlated behaviour that would increase the load following requirement. Since the wind is netted off the demand, this would actually mean that the wind and demand would be moving together in the same direction (both moving upwards, or downwards simultaneously), minimising the deviations in load net of wind. The term "correlated" is used throughout to mean that wind and demand move simultaneously in opposite directions (load is increasing whilst wind is decreasing), since this produces an increase in the load following requirement through increased deviations.

Figure 7.3 – Load following requirement (existing definition) - wind and load separated Scenario 1

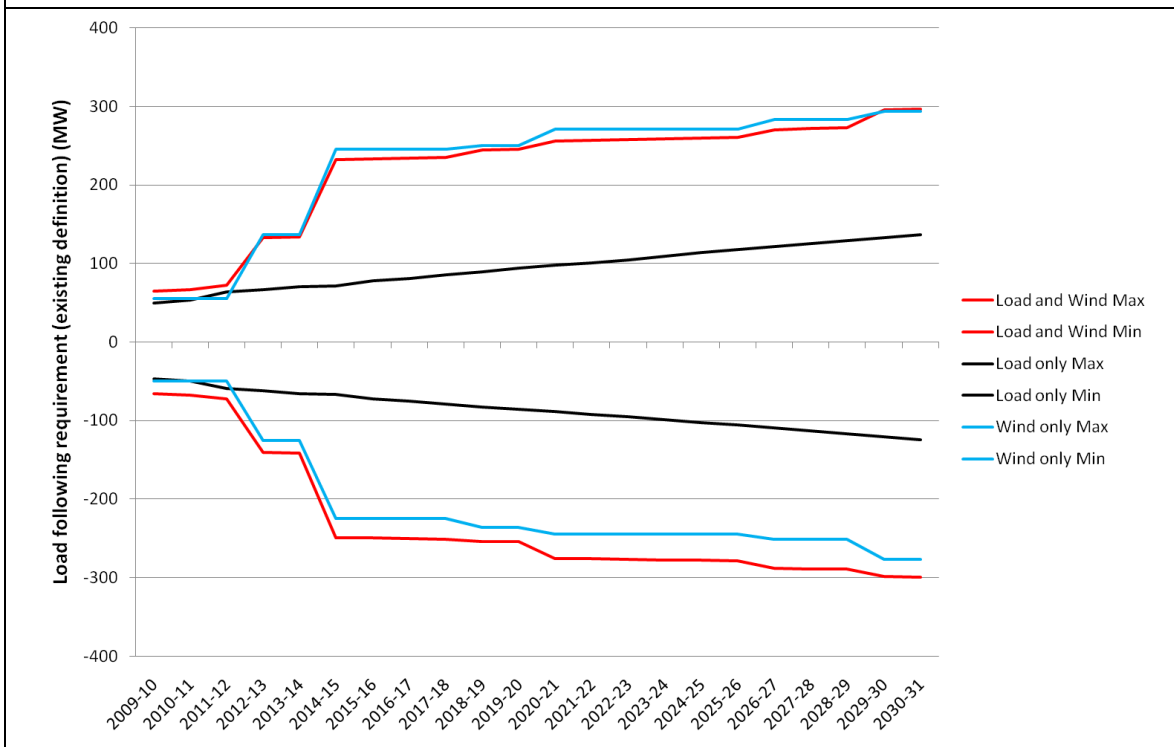

Similar results are observed for Scenarios 2, 3 and 4, as listed in Table 7.3, Table 7.4 and Table 7.5.

Table 7.3 - Forecast Load following requirement - Existing definition - Scenario 2

	Load and Wind		Load only		Wind only	
	Max	Min	Max	Min	Max	Min
2009-10	65	-66	50	-46	55	-49
2010-11	67	-68	53	-50	55	-49
2011-12	72	-72	62	-58	55	-49
2012-13	99	-102	65	-60	96	-87
2013-14	134	-142	68	-63	136	-126
2014-15	134	-142	70	-65	136	-126
2015-16	135	-142	75	-71	136	-126
2016-17	150	-150	78	-73	144	-137
2017-18	151	-151	82	-77	144	-137
2018-19	152	-151	86	-80	144	-137
2019-20	154	-152	90	-83	144	-137
2020-21	155	-153	93	-86	144	-137
2021-22	156	-154	97	-89	144	-137
2022-23	165	-166	101	-93	156	-147
2023-24	166	-168	106	-97	156	-147
2024-25	168	-168	109	-99	156	-147

2025-26	169	-169	112	-102	156	-147
2026-27	171	-170	115	-105	156	-147
2027-28	173	-171	119	-108	156	-147
2028-29	216	-217	122	-111	206	-198
2029-30	217	-218	126	-114	206	-198
2030-31	218	-218	130	-118	206	-198

Table 7.4 - Forecast Load following requirement - Existing definition - Scenario 3

	Load and Wind		Load only		Wind only	
	Max	Min	Max	Min	Max	Min
2009-10	65	-66	50	-47	55	-49
2010-11	66	-68	53	-50	55	-49
2011-12	72	-72	64	-60	55	-49
2012-13	99	-103	67	-62	96	-87
2013-14	134	-141	70	-66	136	-126
2014-15	138	-143	71	-67	138	-128
2015-16	151	-151	78	-72	145	-138
2016-17	152	-152	81	-75	145	-138
2017-18	153	-152	85	-79	145	-138
2018-19	183	-188	90	-82	183	-170
2019-20	184	-188	94	-86	183	-170
2020-21	185	-189	97	-89	183	-170
2021-22	186	-189	101	-92	183	-170
2022-23	198	-193	105	-95	187	-178
2023-24	199	-194	110	-99	187	-178
2024-25	200	-194	114	-102	187	-178
2025-26	202	-195	118	-106	187	-178
2026-27	204	-195	122	-109	187	-178
2027-28	239	-236	125	-114	226	-218
2028-29	240	-237	129	-117	226	-218
2029-30	242	-237	133	-120	226	-218
2030-31	243	-238	137	-124	226	-218

Table 7.5 - Forecast Load following requirement - Existing definition - Scenario 4

	Load and Wind		Load only		Wind only	
	Max	Min	Max	Min	Max	Min
2009-10	65	-67	50	-47	55	-49
2010-11	67	-69	54	-50	55	-49
2011-12	71	-72	61	-57	55	-49
2012-13	99	-103	63	-59	96	-87
2013-14	134	-142	66	-62	136	-126
2014-15	135	-142	70	-65	136	-126
2015-16	135	-143	73	-68	136	-126
2016-17	137	-144	75	-70	137	-126

2017-18	151	-151	79	-73	144	-137
2018-19	152	-152	82	-76	144	-137
2019-20	153	-153	86	-80	144	-137
2020-21	162	-166	88	-82	156	-147
2021-22	164	-167	91	-85	156	-147
2022-23	164	-168	95	-88	156	-147
2023-24	166	-169	99	-92	156	-147
2024-25	167	-169	101	-95	156	-147
2025-26	168	-169	105	-98	156	-147
2026-27	169	-170	107	-101	156	-147
2027-28	171	-170	111	-104	156	-147
2028-29	200	-196	114	-107	184	-174
2029-30	201	-198	118	-110	184	-174
2030-31	203	-199	121	-113	184	-174

7.2) *PROPOSED ALTERNATIVE DEFINITION*

The tables below list the load following metrics calculated according to the proposed alternative definition.

7.2.1) Fast response service

The calculated fast response deviations for each year in each scenario are illustrated in Figure 7.4 and listed in the tables below. These values have been used as an input to the System Frequency Model, outlined in the following section, for determination of the necessary amount of governor response required to maintain frequencies within the required bounds in the one minute timeframe.

Figure 7.4 – Fast Response deviations

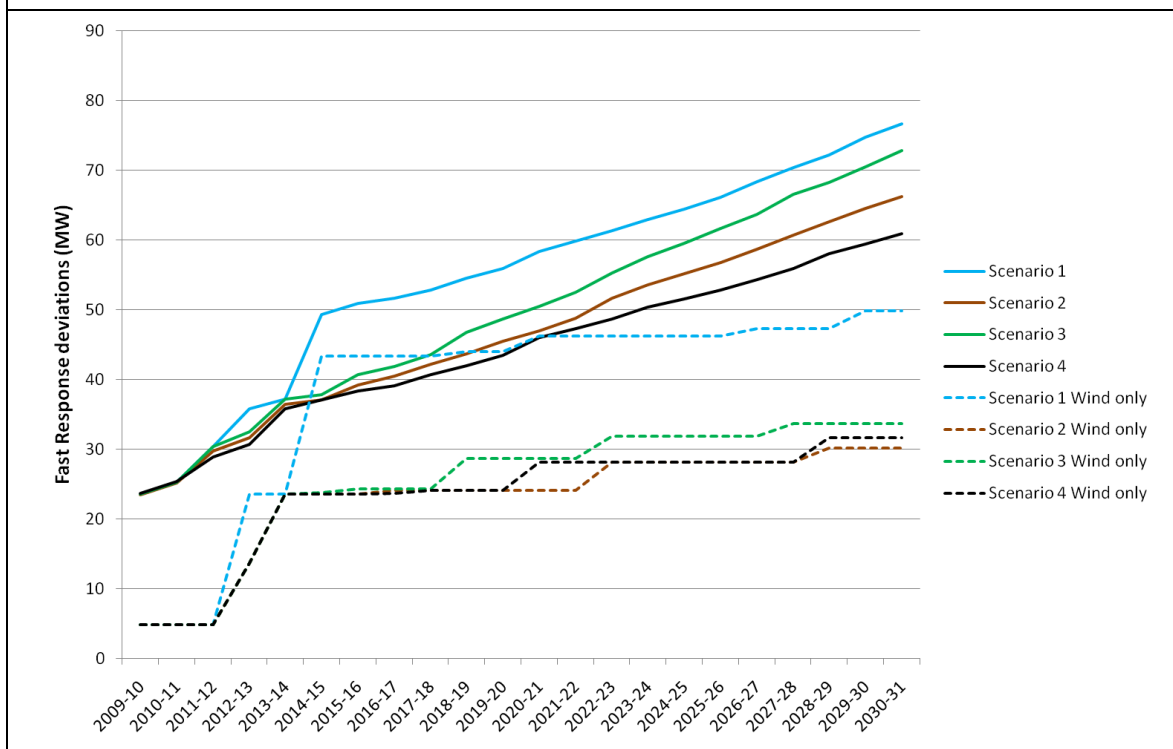

Table 7.6 - Fast Response service requirement (Scenario 1)

	Load and Wind		Load only		Wind only	
	Max	Min	Max	Min	Max	Min
2009-10	24	-22	23	-22	5	-5
2010-11	25	-23	25	-23	5	-5
2011-12	30	-28	30	-28	5	-5
2012-13	36	-35	31	-29	24	-23
2013-14	37	-36	33	-31	24	-23
2014-15	49	-49	34	-31	43	-42
2015-16	51	-51	37	-35	43	-42
2016-17	52	-51	38	-36	43	-42
2017-18	53	-52	40	-38	43	-42
2018-19	55	-54	42	-40	44	-43
2019-20	56	-55	45	-42	44	-43
2020-21	58	-58	47	-44	46	-45
2021-22	60	-59	49	-47	46	-45
2022-23	61	-60	51	-49	46	-45
2023-24	63	-62	54	-51	46	-45
2024-25	64	-63	56	-53	46	-45
2025-26	66	-64	58	-56	46	-45
2026-27	68	-67	61	-58	47	-46
2027-28	70	-68	63	-60	47	-46
2028-29	72	-70	66	-63	47	-46

2029-30	75	-73	68	-65	50	-48
2030-31	77	-75	70	-67	50	-48

Table 7.7 - Fast Response service requirement (Scenario 2)

	Load and Wind		Load only		Wind only	
	Max	Min	Max	Min	Max	Min
2009-10	23	-22	23	-21	5	-5
2010-11	25	-23	25	-23	5	-5
2011-12	30	-28	30	-27	5	-5
2012-13	32	-30	31	-28	14	-13
2013-14	36	-35	32	-30	24	-23
2014-15	37	-36	33	-31	24	-23
2015-16	39	-38	36	-33	24	-23
2016-17	41	-39	37	-34	24	-23
2017-18	42	-40	39	-36	24	-23
2018-19	44	-42	40	-38	24	-23
2019-20	46	-43	43	-40	24	-23
2020-21	47	-45	44	-41	24	-23
2021-22	49	-46	46	-43	24	-23
2022-23	52	-49	48	-45	28	-28
2023-24	54	-51	50	-47	28	-28
2024-25	55	-53	52	-49	28	-28
2025-26	57	-54	53	-51	28	-28
2026-27	59	-56	55	-52	28	-28
2027-28	61	-58	57	-55	28	-28
2028-29	63	-60	59	-56	30	-30
2029-30	65	-61	61	-58	30	-30
2030-31	66	-63	63	-60	30	-30

Table 7.8 - Fast Response service requirement (Scenario 3)

	Load and Wind		Load only		Wind only	
	Max	Min	Max	Min	Max	Min
2009-10	24	-22	23	-22	5	-5
2010-11	25	-23	25	-23	5	-5
2011-12	30	-28	30	-28	5	-5
2012-13	33	-31	31	-29	14	-13
2013-14	37	-36	33	-31	24	-23
2014-15	38	-36	34	-31	24	-23
2015-16	41	-39	37	-35	24	-24
2016-17	42	-40	38	-36	24	-24
2017-18	44	-42	40	-38	24	-24
2018-19	47	-45	42	-40	29	-27
2019-20	49	-47	45	-42	29	-27
2020-21	51	-49	47	-44	29	-27

2021-22	53	-50	49	-47	29	-27
2022-23	55	-54	51	-49	32	-31
2023-24	58	-55	54	-51	32	-31
2024-25	60	-57	56	-53	32	-31
2025-26	62	-59	58	-56	32	-31
2026-27	64	-61	61	-58	32	-31
2027-28	67	-64	63	-60	34	-33
2028-29	68	-66	66	-63	34	-33
2029-30	71	-67	68	-65	34	-33
2030-31	73	-70	70	-67	34	-33

Table 7.9 - Fast Response service requirement (Scenario 4)

	Load and Wind		Load only		Wind only	
	Max	Min	Max	Min	Max	Min
2009-10	24	-22	24	-22	5	-5
2010-11	25	-24	25	-23	5	-5
2011-12	29	-27	29	-27	5	-5
2012-13	31	-29	30	-28	14	-13
2013-14	36	-34	31	-29	24	-23
2014-15	37	-35	33	-31	24	-23
2015-16	38	-37	34	-32	24	-23
2016-17	39	-37	35	-33	24	-23
2017-18	41	-39	37	-34	24	-23
2018-19	42	-40	39	-36	24	-23
2019-20	44	-41	40	-37	24	-23
2020-21	46	-44	42	-39	28	-28
2021-22	47	-46	43	-40	28	-28
2022-23	49	-47	45	-42	28	-28
2023-24	50	-48	46	-43	28	-28
2024-25	52	-49	48	-44	28	-28
2025-26	53	-50	49	-46	28	-28
2026-27	54	-52	51	-47	28	-28
2027-28	56	-53	53	-49	28	-28
2028-29	58	-56	54	-50	32	-31
2029-30	59	-57	56	-52	32	-31
2030-31	61	-58	57	-53	32	-31

7.2.2) Regulation service

Figure 7.5 illustrates the regulation requirement in each year in each scenario, calculated according to the proposed alternative methodology outlined previously. Values as calculated are listed in the tables following.

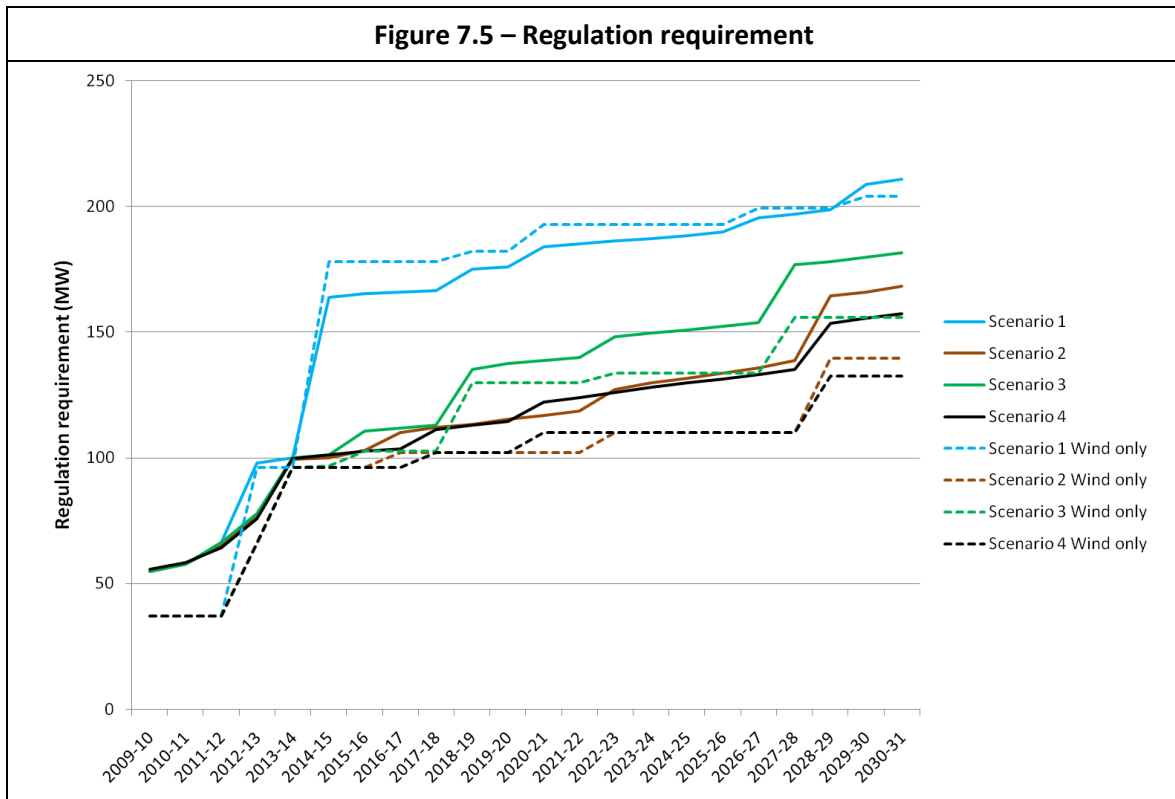

Regulation requirements for loads only are identical to the load following requirement calculated using the existing methodology, since the same metric has been used. Regulation requirements for wind only are 30% smaller than the load following requirement as calculated using the existing methodology, since the expected wind is calculated based upon the 30 minutes of wind data immediately previous (instead of 45 minutes to 15 minutes earlier). This assumes that communication facilities are sufficient such that wind farm outputs can be known by System Management within one minute.

The reduction in the regulation requirement compared with the existing load following methodology is accounted for by the inclusion of the slow following service. Utilising plant that is slower to respond, but can adjust output as required on a slower timeframe, is likely to be a more cost effective way of maintaining frequency control. For example, a slow response raise service could be provided by OCGT plant that is not operating, but could be switched on within a 15 min timeframe (and similarly a lower service by OCGT plant that could be switched off within 15 min). This removes the need for this plant to be constrained on or off at minimum load.

Table 7.10 - Regulation service requirement (Scenario 1)

	Load and Wind		Load only		Wind only	
	Max	Min	Max	Min	Max	Min
2009-10	55	-53	50	-47	37	-35
2010-11	58	-55	53	-50	37	-35
2011-12	66	-63	64	-60	37	-35

2012-13	98	-106	67	-62	96	-87
2013-14	100	-107	70	-66	96	-87
2014-15	164	-183	71	-67	178	-156
2015-16	165	-184	78	-72	178	-156
2016-17	166	-184	81	-75	178	-156
2017-18	167	-184	85	-79	178	-156
2018-19	175	-188	90	-82	182	-165
2019-20	176	-188	94	-86	182	-165
2020-21	184	-197	97	-89	193	-172
2021-22	185	-198	101	-92	193	-172
2022-23	186	-198	105	-95	193	-172
2023-24	187	-199	110	-99	193	-172
2024-25	188	-200	114	-102	193	-172
2025-26	190	-200	118	-106	193	-172
2026-27	195	-209	122	-109	199	-179
2027-28	197	-210	125	-114	199	-179
2028-29	199	-210	129	-117	199	-179
2029-30	209	-215	133	-120	204	-190
2030-31	211	-216	137	-124	204	-190

Table 7.11 - Regulation service requirement (Scenario 2)

	Load and Wind		Load only		Wind only	
	Max	Min	Max	Min	Max	Min
2009-10	55	-54	50	-46	37	-35
2010-11	58	-56	53	-50	37	-35
2011-12	65	-62	62	-58	37	-35
2012-13	77	-77	65	-60	66	-58
2013-14	100	-107	68	-63	96	-87
2014-15	100	-107	70	-65	96	-87
2015-16	103	-108	75	-71	96	-87
2016-17	110	-114	78	-73	102	-94
2017-18	112	-115	82	-77	102	-94
2018-19	113	-116	86	-80	102	-94
2019-20	115	-117	90	-83	102	-94
2020-21	117	-118	93	-86	102	-94
2021-22	119	-119	97	-89	102	-94
2022-23	127	-127	101	-93	110	-102
2023-24	130	-128	106	-97	110	-102
2024-25	132	-129	109	-99	110	-102
2025-26	134	-130	112	-102	110	-102
2026-27	136	-132	115	-105	110	-102
2027-28	139	-134	119	-108	110	-102
2028-29	165	-159	122	-111	140	-139
2029-30	166	-160	126	-114	140	-139

2030-31	168	-160	130	-118	140	-139
---------	-----	------	-----	------	-----	------

Table 7.12 - Regulation service requirement (Scenario 3)

	Load and Wind		Load only		Wind only	
	Max	Min	Max	Min	Max	Min
2009-10	55	-53	50	-47	37	-35
2010-11	58	-55	53	-50	37	-35
2011-12	66	-63	64	-60	37	-35
2012-13	78	-77	67	-62	66	-58
2013-14	100	-107	70	-66	96	-87
2014-15	101	-107	71	-67	97	-89
2015-16	111	-113	78	-72	103	-95
2016-17	112	-114	81	-75	103	-95
2017-18	113	-115	85	-79	103	-95
2018-19	135	-139	90	-82	130	-117
2019-20	138	-140	94	-86	130	-117
2020-21	139	-140	97	-89	130	-117
2021-22	140	-141	101	-92	130	-117
2022-23	148	-146	105	-95	134	-126
2023-24	150	-148	110	-99	134	-126
2024-25	151	-149	114	-102	134	-126
2025-26	152	-150	118	-106	134	-126
2026-27	154	-151	122	-109	134	-126
2027-28	177	-171	125	-114	156	-154
2028-29	178	-173	129	-117	156	-154
2029-30	180	-174	133	-120	156	-154
2030-31	181	-174	137	-124	156	-154

Table 7.13 - Regulation service requirement (Scenario 4)

	Load and Wind		Load only		Wind only	
	Max	Min	Max	Min	Max	Min
2009-10	56	-54	50	-47	37	-35
2010-11	58	-56	54	-50	37	-35
2011-12	64	-62	61	-57	37	-35
2012-13	76	-77	63	-59	66	-58
2013-14	100	-107	66	-62	96	-87
2014-15	101	-107	70	-65	96	-87
2015-16	103	-108	73	-68	96	-87
2016-17	104	-108	75	-70	96	-87
2017-18	111	-115	79	-73	102	-94
2018-19	113	-116	82	-76	102	-94
2019-20	114	-117	86	-80	102	-94
2020-21	122	-123	88	-82	110	-102
2021-22	124	-124	91	-85	110	-102

2022-23	126	-125	95	-88	110	-102
2023-24	128	-127	99	-92	110	-102
2024-25	130	-128	101	-95	110	-102
2025-26	131	-129	105	-98	110	-102
2026-27	133	-130	107	-101	110	-102
2027-28	135	-131	111	-104	110	-102
2028-29	153	-151	114	-107	132	-124
2029-30	156	-151	118	-110	132	-124
2030-31	157	-153	121	-113	132	-124

7.2.3) Slow following service

Figure 7.6 shows the slow following service requirement, calculated according to the proposed alternative methodology outlined earlier. Values as calculated are listed in the tables following.

The slow following service is large in quantity, but can be provided by plant that is slow to respond (a 15 minute delay is acceptable). This service takes account of the large coarse fluctuations in demand and intermittent generation. It is clear that this service is driven heavily by shifts in demand throughout the day, and is less dependent upon the activities of intermittent generation. This remains the case even with the highest levels of intermittent generation modelled.

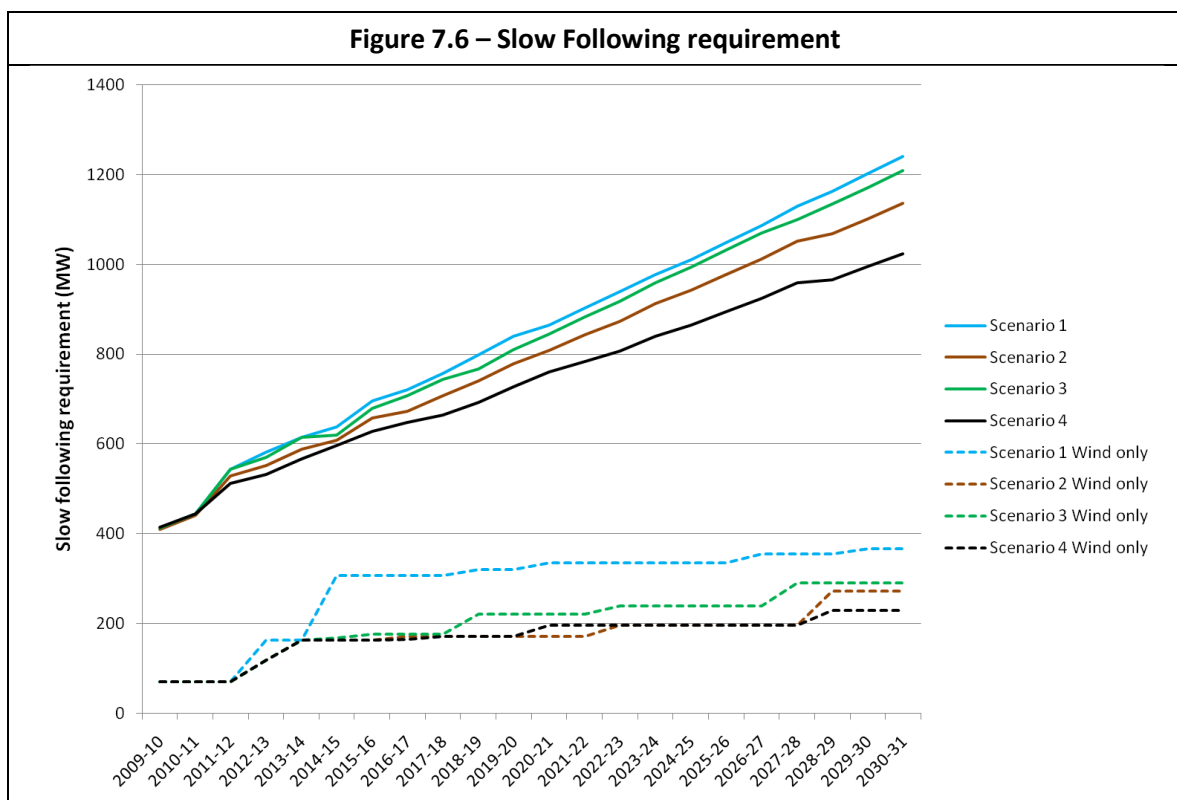

These results suggest that the Slow Following service will remain relatively unaffected by the penetration of intermittent generation, and will continue to be dominated by variability in the load.

Load variability will gradually increase as the load increases, but since it is not due to wind generation, it has not been dealt with further in this study.

Table 7.14 - Forecast slow following service requirement (Scenario 1)

	Load and Wind		Load only		Wind only	
	Max	Min	Max	Min	Max	Min
2009-10	412	-408	416	-408	70	-64
2010-11	444	-440	449	-440	70	-64
2011-12	544	-537	547	-537	70	-64
2012-13	582	-557	566	-557	162	-151
2013-14	614	-588	598	-588	162	-151
2014-15	637	-597	607	-597	307	-296
2015-16	697	-657	669	-657	307	-296
2016-17	721	-684	697	-684	307	-296
2017-18	758	-719	733	-719	307	-296
2018-19	799	-754	768	-754	319	-295
2019-20	840	-794	809	-794	319	-295
2020-21	865	-827	842	-827	335	-301
2021-22	903	-863	880	-863	335	-301
2022-23	940	-900	917	-900	335	-301
2023-24	977	-941	959	-941	335	-301
2024-25	1011	-973	992	-973	335	-301
2025-26	1049	-1010	1030	-1010	335	-301
2026-27	1087	-1047	1067	-1047	355	-307
2027-28	1129	-1088	1109	-1088	355	-307
2028-29	1163	-1120	1142	-1120	355	-307
2029-30	1202	-1156	1180	-1156	366	-338
2030-31	1241	-1193	1217	-1193	366	-338

Table 7.15 - Forecast slow following service requirement (Scenario 2)

	Load and Wind		Load only		Wind only	
	Max	Min	Max	Min	Max	Min
2009-10	409	-405	413	-405	70	-64
2010-11	441	-437	446	-437	70	-64
2011-12	529	-523	532	-523	70	-64
2012-13	551	-538	547	-538	117	-112
2013-14	587	-564	574	-564	162	-151
2014-15	607	-583	593	-583	162	-151

2015-16	657	-631	642	-631	162	-151
2016-17	673	-656	667	-656	170	-170
2017-18	708	-689	702	-689	170	-170
2018-19	741	-721	735	-721	170	-170
2019-20	779	-758	773	-758	170	-170
2020-21	809	-786	801	-786	170	-170
2021-22	843	-819	834	-819	170	-170
2022-23	874	-851	867	-851	197	-186
2023-24	913	-888	905	-888	197	-186
2024-25	943	-916	933	-916	197	-186
2025-26	978	-948	966	-948	197	-186
2026-27	1012	-981	999	-981	197	-186
2027-28	1052	-1018	1037	-1018	197	-186
2028-29	1068	-1046	1065	-1046	271	-249
2029-30	1102	-1078	1099	-1078	271	-249
2030-31	1137	-1110	1132	-1110	271	-249

Table 7.16 - Forecast slow following service requirement (Scenario 3)

	Load and Wind		Load only		Wind only	
	Max	Min	Max	Min	Max	Min
2009-10	412	-408	416	-408	70	-64
2010-11	444	-440	449	-440	70	-64
2011-12	544	-537	547	-537	70	-64
2012-13	570	-557	566	-557	117	-112
2013-14	614	-588	598	-588	162	-151
2014-15	619	-597	607	-597	168	-152
2015-16	679	-657	669	-657	176	-170
2016-17	708	-684	697	-684	176	-170
2017-18	744	-719	733	-719	176	-170
2018-19	767	-754	768	-754	221	-202
2019-20	810	-794	809	-794	221	-202
2020-21	845	-827	842	-827	221	-202
2021-22	883	-863	880	-863	221	-202
2022-23	917	-900	917	-900	240	-218
2023-24	960	-941	959	-941	240	-218
2024-25	994	-973	992	-973	240	-218
2025-26	1032	-1010	1030	-1010	240	-218
2026-27	1071	-1047	1067	-1047	240	-218
2027-28	1100	-1088	1109	-1088	290	-267
2028-29	1134	-1120	1142	-1120	290	-267
2029-30	1171	-1156	1180	-1156	290	-267
2030-31	1209	-1193	1217	-1193	290	-267

Table 7.17 - Forecast slow following service requirement (Scenario 4)

	Load and Wind		Load only		Wind only	
	Max	Min	Max	Min	Max	Min
2009-10	414	-410	418	-410	70	-64
2010-11	444	-441	449	-441	70	-64
2011-12	513	-507	516	-507	70	-64
2012-13	532	-520	530	-520	117	-112
2013-14	566	-544	555	-544	162	-151
2014-15	597	-574	585	-574	162	-151
2015-16	627	-603	615	-603	162	-151
2016-17	647	-621	633	-621	164	-151
2017-18	665	-650	662	-650	170	-170
2018-19	693	-677	690	-677	170	-170
2019-20	727	-710	723	-710	170	-170
2020-21	760	-733	745	-733	197	-186
2021-22	783	-761	774	-761	197	-186
2022-23	806	-789	802	-789	197	-186
2023-24	840	-822	836	-822	197	-186
2024-25	865	-845	860	-845	197	-186
2025-26	895	-873	889	-873	197	-186
2026-27	925	-901	917	-901	197	-186
2027-28	960	-935	951	-935	197	-186
2028-29	966	-957	975	-957	230	-214
2029-30	995	-985	1003	-985	230	-214
2030-31	1024	-1013	1032	-1013	230	-214

7.3) ABILITY OF PLANT TO PROVIDE REQUIRED LOAD FOLLOWING SERVICES

Verve currently has available a total quantity of 323 MW of load following capability, through the use of all Pinjar units, the Mungarra units, and two new LMS100 units (due for commissioning in 2011). According to the requirements calculated above, this capacity will be sufficient to provide the load following services in every scenario, in every year, with the exception of the slow following service. Slow following can be assumed to be provided with a wider range of plant, since only a slow response is required.

These results suggest that Verve has the technical ability to provide the load following services required, even in the most extreme case, to 2030.

In this regard, it could be considered that existing plant operating under the existing rules could continue to provide the load following services required until 2030, even under a "worst case" scenario with very high wind penetration.

It should be noted that providing up to 300 MW of load following (as necessary in Scenario 1 in 2030-31) will require the continuous operation of almost all of Verve's plant capable of providing load following. Since load following plant must be dispatched at the mid-point between minimum and maximum load, this suggests that 548 MW of OCGT capacity would need to be dispatched on a continuous basis. This is likely to be costly, and to cause issues at time of minimum load. These and other challenges are addressed in more detail in section 12).

A large number of new OCGT plant is forecast to be commissioned throughout the course of this study, and it is likely that this newer plant could more efficiently and cost effectively provide load following services than the existing Verve OCGTs. The introduction of an efficient competitive market for provision of ancillary services is therefore recommended.

8) DISPATCH MERIT ORDER

An accurate understanding of the dispatch merit order in the SWIS is important for this study for two reasons:

1. For system frequency modelling it is important to know which plant will be online at the time of a disturbance of interest, and will therefore be providing inertia and governor response. ROAM has used a dispatch merit order determined for each scenario in each year to analyse the plant that will be online at time of minimum load, maximum load and an intermediate load level, to analyse the impacts of wind disturbances at the levels expected in each year.
2. To determine the costs of providing ancillary services. A clear model of the dispatch merit order under various conditions can provide insight into the operation of the SWIS system as the penetration of intermittent generation grows and larger quantities of load-following plant must be kept online, particularly at times of low load.

Dispatch in the SWIS is complicated and will vary with many parameters including time of day. The dispatch order may also change at times of low load reduction and decommitment. In order to conduct this analysis it is necessary to construct a single dispatch order that captures the relevant features. ROAM has used the best available information, market knowledge and discussion with System Management to construct the dispatch merit order listed in Table C.1 in the appendix.

The order is based upon the following general principles:

- Plant required for load following purposes is dispatched first, followed by cogeneration plant (considered to be "must run")
- IPPs are generally dispatched prior to Verve plant

- Plant are generally dispatched in order of short run marginal costs (coal before CCGT before OCGT)
- Likely start-up costs of each plant are reflected in the decommitment order.

The order is based upon the principles illustrated in Table 8.1. This is not intended to be a suggested merit order for comparing various technologies, but is simply intended as a tool for conducting this analysis. The majority of the focus of this study will be upon the relationship between the intermittent renewables and the large thermal stations at time of minimum load, so it is therefore most important that the relationship between these is reflective of reality.

The full dispatch merit order developed for this study is listed in Table C.1 in the appendix.

Table 8.1 – Principles of dispatch merit order			
	Plant type	Participant	Dispatched to:
1	Plant required for load following	Verve	Level necessary to provide load following (mid-point between minimum load and maximum load)
2	Cogeneration	IPPs	Minimum load
3	Cogeneration	Verve	Minimum load
4	Intermittent renewables	IPPs	Maximum available load
5	Intermittent renewables	Verve	Maximum available load
6	Biomass	IPPs	Minimum load
7	Large thermal stations (coal-fired)	IPPs	Minimum load
8	Large thermal stations (coal-fired)	Verve	Minimum load
9	Geothermal	IPPs	Minimum load
10	CCGTs	IPPs	Minimum load
11	CCGTs	Verve	Minimum load
12	Cogeneration	IPPs	Maximum load
13	Cogeneration	Verve	Maximum load
14	Geothermal/Biomass	IPPs	Maximum load
15	Large thermal stations (coal-fired)	IPPs	Maximum load
16	Large thermal stations (coal-fired)	Verve	Maximum load
17	CCGTs	IPPs	Maximum load
18	CCGTs	Verve	Maximum load
19	OCGTs	IPPs	Maximum load
20	OCGTs	Verve	Maximum load

21	Diesel	IPPs	Maximum load
22	DSM	IPPs	Maximum load

Dispatch of intermittent renewable plant

In the dispatch order intermittent renewables are dispatched to their maximum available loads immediately following the dispatch of cogeneration plant. Wind generation was dispatched below coal-fired generation for the reasons outlined in Table 8.2. In addition, this dispatch most closely approximates the manner in which wind generation is currently dispatched.

Table 8.2 – Comparison of dispatch of coal-fired generation and wind generation

	Coal-fired generation	Wind generation
Short run marginal cost	Coal-fired generation has associated short run marginal costs, including fuel costs and emissions costs (this scenario includes a -5% carbon price trajectory). These costs are calculated to be around \$30-\$31 before a carbon price is applied (2009-10), and increase to \$39 when a carbon price is applied. With an increasing carbon price trajectory the SRMC of coal-fired generation increases \$76 by the end of the study.	Wind generation has negligible short run marginal costs.
Opportunity costs	Coal-fired generation has no opportunity costs.	Wind generation receives revenue from the sale of renewable energy certificates (RECs), regardless of the wholesale electricity price. RECs typically sell for \$55-\$60, meaning that wind generators face an opportunity cost of \$55-\$60 by curtailing operation. This means that wind generation is incentivised to bid at -\$55 to -\$60
Start-up / Shut-down costs	Start-up/shut-down costs can vary widely from generator to generator. Typical estimates range from \$28/MW/start ²¹ to \$35/MW/start ²² when accounting for	There are no start-up/shut-down costs associated with wind generation.

²¹ N. Troy, E. Denny, M. O'Malley, "Base-load cycling on a system with significant wind penetration", IEEE Transactions on Power Systems, Vol. 25, No.2, May 2010.

²² A. S. Malik, B. J. Cory, "Impact of DSM on Energy Production Cost and Start-up and Shut-down costs of thermal units", IEEE, Proceedings of the 4th International Conference on Advances in Power System Control, Operation and Management, APSCOM-97, Hong Kong, November 1997.

	<p>fuel and auxiliary loads used during start-up. Other estimates attempt to include unit wear and tear, which is estimated to increase costs to the range of \$60/MW/start to \$220/MW/start²³.</p> <p>Assuming a 5hr shutdown period, coal fired generators may be incentivised to bid \$24 to \$88/MWh below SRMC to avoid start-up costs (assuming overnight operation at minimum load to minimise losses).</p>	
<p>Summary</p>	<p>Coal-fired generation may be incentivised to bid as low as \$6 to -\$58 /MWh in the absence of a carbon price (SRMC of \$30, minus \$24 to \$88) to avoid start-up costs), or \$15 to -\$48 /MWh in the presence of a carbon price.</p> <p>Wind generators are incentivised to bid at around -\$55 /MWh to gain revenue from RECs. Therefore, in a competitive market, it is expected that in most circumstances wind generation would be dispatched ahead of coal-fired generation, and that start-up costs are likely to be insufficient incentive for coal-fired generation to be dispatched ahead of wind generation, except in the most extreme cases.</p>	

For this analysis ROAM has utilised a dispatch order that is as close to the existing dispatch merit order as possible. This allows insight into the impact of wind penetration on the existing system, if nothing is changed (facilitating highlighting of any potential issues).

The dispatch order may change in future, potentially with a shift towards a more competitive dispatch based more closely upon short run marginal cost.

Available Inertia - Input to System Frequency Model

The dispatch merit order was used in conjunction with forecast minimum and maximum load levels for each year of each scenario to determine the plant that would be online at those times providing system inertia. Tables in the appendix (Table E.1, Table E.2, Table E.3 and Table E.4) indicate the amount of each plant online at each time (minimum load, maximum load, and an intermediate load level). These values were used as an input to the system frequency model for determining the required governor response to maintain stable frequencies with increasing fast deviations due to the penetration of intermittent generation.

²³ S. Lefton, P. Besuner and G. Grimsrud, "Understand what it really costs to cycle fossil-fired units", Fossil-Fired steam/electric, Power, March/April 1997.

9) SYSTEM FREQUENCY MODEL

To determine the adequacy of current frequency control services for forecast levels of intermittent generation, ROAM needed to analyse the impact of different levels of intermittent generation on system frequency. To do this, ROAM utilised a system dispatch engine to first produce representative dispatch patterns or system state for the different scenarios at different loading (typical high, medium and low) conditions. Each system state is then loaded into a system frequency model together with a projected intermittent generation disturbance trace (based on the amount of intermittent generation penetration and analysis of past wind farm generation patterns in the SWIS) to calculate the resulting system frequency variation.

Having identified the possible frequency disturbances for different generation mixes, the outcomes are then compared with the current rules and make judgement on the adequacy of the Rules. Should the Rules be inadequate or curtailment of intermittent generation is required, the associated cost and possible remedies are then identified and discussed.

9.1) DEVELOPMENT OF THE SYSTEM FREQUENCY MODEL

ROAM has produced a system frequency model, outlined in Figure 9.1, to perform detailed modelling of the system frequency response in the SWIS. To ensure the accuracy of the model, it was carefully calibrated with generator inertia and governor/turbine data provided by Western Power, and compared against actual system frequency of past generator contingency events. Details of this are discussed in a later section of this report, whilst the remainder of this section will be focusing on the derivation of the model and its parameters.

ROAM has developed a customised system frequency model of the SWIS, to perform detailed modelling of the system frequency response in the SWIS with high levels of wind penetration.

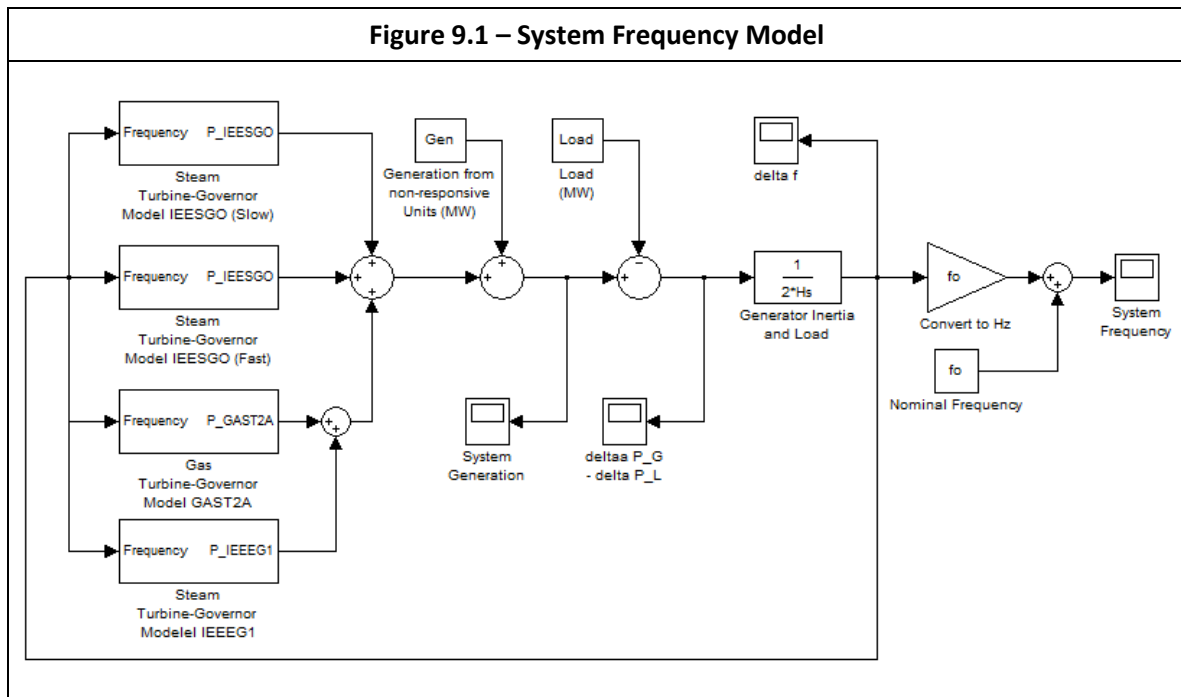

9.1.1) Generator and Load Model

For a single generator supplying power to a load, the rate of change in electrical frequency due to a difference between the power supplied and the power consumed by the load can be calculated as

$$\frac{df(t)}{dt} = \frac{f_s \cdot (P_{Gen}(t) - P_{Load}(t))}{2H_{Gen}} \tag{1}$$

where $P_{Gen}(t)$ and $P_{Load}(t)$ is the output of the generator and load, respectively, and f_s is the nominal frequency (50Hz), and H_{Gen} is the inertia of the generator, turbine and all other connecting plant in MWs. This is known as the Swing Equation²⁴.

For a system with M generators and N loads, if we are only interested in the average system dynamics (ignoring the inter-machine oscillations), we can model the system as a single-machine²⁵ and apply the Swing Equation accordingly by summing the contribution of each generator and load. That is,

$$\frac{df(t)}{dt} = \frac{f_s \cdot \left(\sum_{i=1}^M P_{Gen_i}(t) - \sum_{j=1}^N P_{Load_j}(t) \right)}{2 \sum_{i=1}^M H_{Gen_i}} = \frac{f_s \cdot (P_G(t) - P_L(t))}{2H} \tag{2}$$

²⁴ H. Saadat, "Power System Analysis", International Editions, McGraw-Hill, 1999.

²⁵ A. Li and Z. Cai, "A Method for Frequency Dynamics Analysis and Load Shedding Assessment Based on the Trajectory of Power System Simulation", Electric Utility Deregulation and Restructuring and Power Technologies Conference, April 2008.

where $P_G(t)$ and $P_L(t)$ is the system generation and load, respectively, and H is the centre of inertia (COI) of the system supplied by active generators. Expressing the Swing Equation in terms of a transfer function in the s -domain gives

$$\frac{F(s)}{P_G(s) - P_L(s)} = \frac{f_s}{2H \cdot s} \quad (3)$$

which is used to form the basis of the generator model after replacing absolute values $P_G(s)$, $P'_L(s)$, and $F(s)$ with small signal representations $\Delta P_G(s)$, $\Delta P'_L(s)$ and $\Delta F(s)$.

Power system loads consists of a variety of electrical devices. For resistive loads, such as lighting and heating loads, the electrical power is independent of frequency. Motor loads, however, are sensitive to changes in frequency. The amount of sensitivity depends on the composite of the speed-load characteristics of all the driven devices. Here, we model speed-load characteristic of a composite load as

$$P_L(t) = P'_L(t) \cdot \left(\frac{f(t)}{f_s} \right)^m \quad (4)$$

where $P'_L(t)$ is the total system load in the absence of frequency deviation and m is the load-frequency index.

To make sure that correct generator inertia values are applied in ROAM's modelling of the SWIS, ROAM has requested and obtained generator inertia data from Western Power and applied those accordingly in the modelling. The load-frequency index, however, was difficult to obtain as advised by Western Power. ROAM has nominated a value of 1.5 for m as it was shown to give good benchmark outcomes of historic contingency events.

9.1.2) Governor-Turbine Models

Accurate modelling of generator governors and turbines is essential to determine system frequency response. Equipments such as the speed governor controller and the governor itself cannot respond instantaneously in the presence of system frequency change. Instead, exponential responses governed by time-constants, or time delay responses, or in some cases more complex response types are to be expected. Similarly, components associated with the turbine such as fuel controllers, valve positioning devices and temperature controllers also inhibit those characteristics. The combination of different responses from governors and turbines can have a significant influence on the system frequency response.

To ensure accuracy in ROAM's modelling, ROAM has requested and obtained governor and turbine models from Western Power for every generator in the SWIS. Ideally, every generator governor and turbine should be modelled accordingly in the system model. However, since there were governor-turbine models missing for a small number of generators, and significant amount

of similarities were observed in the modelling parameters, ROAM decided that it was more efficient to model the governors and turbines based on their relevant types. In particular, a total of four governor-turbine models, namely IEESGO (Slow), IEESGO (Fast), GAST2A and IEEEG1, were employed. Table 9.1 summarises the generators in the SWIS and the corresponding governor-turbine models applied in ROAM's modelling. Note that generators with no governor-turbine model present will be assumed to have no governor response.

Table 9.1 – SWIS Generators and the Corresponding Governor-Turbine Models			
Generator	Governor-Turbine Model	Generator	Governor-Turbine Model
Kwinana G1	IEESGO (Slow)	Cockburn GT	GAST2A
Kwinana G2	IEESGO (Slow)	Cockburn SG	IEEEG1
Kwinana G3	IEESGO (Slow)	Kwinana GT1	GAST2A
Kwinana G4	IEESGO (Slow)	Geraldton GT1	GAST2A
Kwinana G5	IEESGO (Slow)	West Kalgoorlie GT2	GAST2A
Kwinana G6	IEESGO (Slow)	West Kalgoorlie GT3	GAST2A
Muja G1	IEESGO (Fast)	Mungarra GT1	GAST2A
Muja G2	IEESGO (Fast)	Mungarra GT2	GAST2A
Muja G3	IEESGO (Fast)	Mungarra GT3	GAST2A
Muja G4	IEESGO (Fast)	Pinjar GT1	GAST2A
Muja G5	IEESGO (Slow)	Pinjar GT2	GAST2A
Muja G6	IEESGO (Slow)	Pinjar GT3	GAST2A
Muja G7	IEESGO (Slow)	Pinjar GT4	GAST2A
Muja G8	IEESGO (Slow)	Pinjar GT5	GAST2A
Collie G1	IEESGO (Slow)	Pinjar GT6	GAST2A
Bluewaters G1	IEESGO (Slow)	Pinjar GT7	GAST2A
Bluewaters G2	IEESGO (Slow)	Pinjar GT9	GAST2A
Alinta Pinjara GT1	No model present	Pinjar GT10	GAST2A
Alinta Pinjara GT2	No model present	Pinjar GT11	GAST2A
Alinta WG GT1	No model present	Worsley GT	GAST2A
Alinta WG GT2	No model present	Newgen Kwinana GT	No model present
		Newgen Kwinana SG	No model present

Details of the governor-turbine models are discussed in the following sections.

The IESGO Model

The IESGO governor-turbine model is used for modelling the majority of steam turbine generators. A block diagram representation of this model is outlined in Figure 9.2.

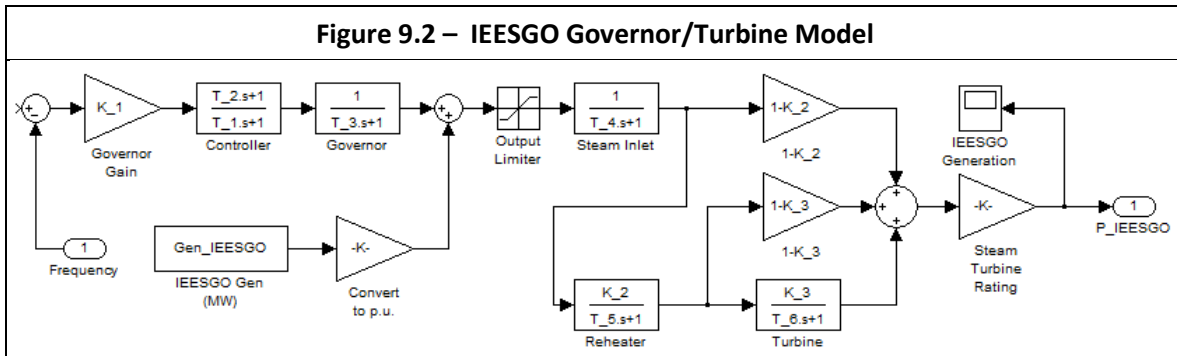

The model parameters provided by Western Power suggested that generators modelled by the IESGO model can be subdivided into two distinct classes as significant differences in the time-constant for the Reheater was observed. In particular, some time-constants are in the range of 0.1 seconds while the rest around 10 seconds. Therefore, ROAM has subdivided generators modelled by the IESGO into IESGO (Fast) and IESGO (Slow) classes. Table 9.2 summarises the parameters assigned for each of the two classes.

Parameter	Description	Slow	Fast
T ₁	Controller time-constant (s)	0.1	0.46
T ₂	Controller lead compensation (s)	0	0.3
T ₃	Governor time-constant (s)	0.2	0.23
T ₄	Steam inlet time-constant (s)	0.13	0.21
T ₅	Reheater time-constant (s)	10.07	0.15
T ₆	Turbine time-constant (s)	1	0
K ₁	Inverse of Governor Droop ²⁶	20	20
K ₂	Constant gain	0.73	0.28
K ₃	Constant gain	0.67	0

²⁶ Governor droop is normally 4% for most units. In addition, there are some times when the governors are set on isochronous control to manage frequency.

The GAST2A Model

The GAST2A governor-turbine model is used for modelling gas turbines generators. A block diagram representation of this model is outlined in Figure 9.3, with the associated parameters outlined in Table 9.3.

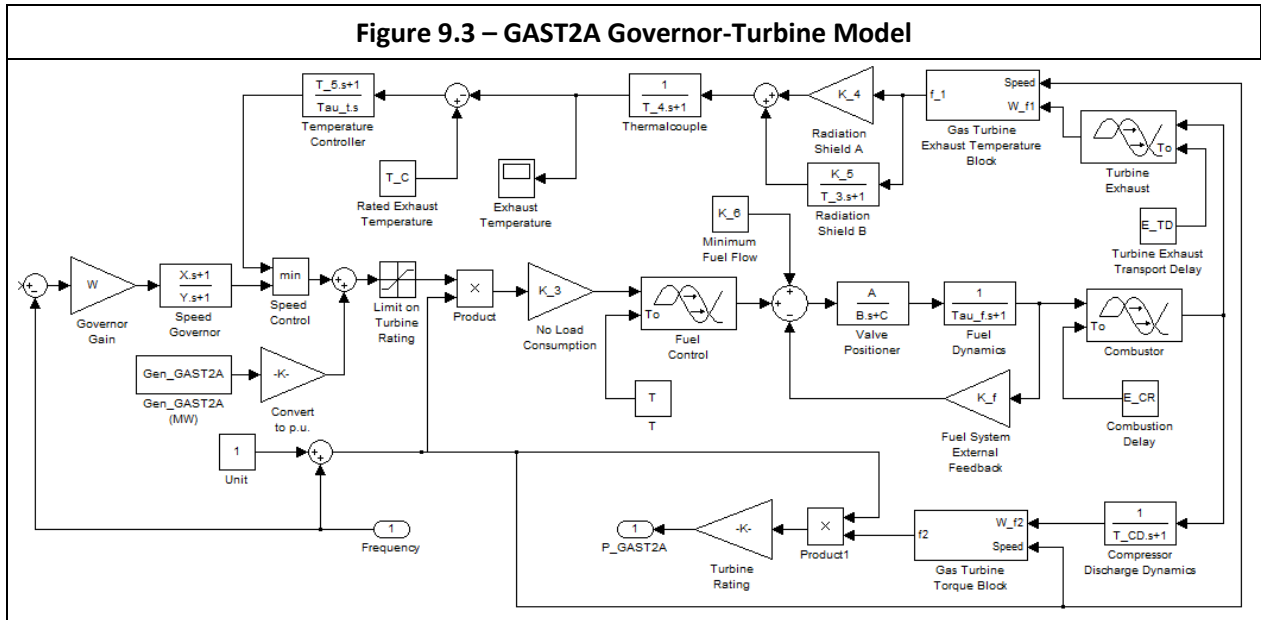

Table 9.3 – GAST2A Model Parameters

Parameter	Description	Value
W	Inverse of governor droop	20
X	Controller lead compensation (s)	0
Y	Governor time-constant (s)	0.05
E _{TD}	Turbine and Exhaust transport delay (s)	0.04
T _{CD}	Compressor discharge time-constant (s)	0.2
T	Fuel control delay (s)	0.12
E _{CR}	Combustor delay (s)	0.01
K ₃	Fuel control gain	0.77
A	Valve positioner gain	1
B	Valve positioner time-constant (s)	0.05
τ_f	Fuel system time-constant (s)	0.4
K ₅	Radiation shield gain	0.2
K ₄	Radiation shield gain	0.8

Table 9.3 – GAST2A Model Parameters

Parameter	Description	Value
T_3	Radiation shield time-constant (s)	15
T_4	Thermalcouple time-constant (s)	2.5
τ_t	Temperature control ($^{\circ}$ F)	450
T_5	Temperature controller time-constant (s)	3.3
A_{f1}	Gas turbine exhaust temperature block parameter ($^{\circ}$ F)	700
B_{f1}	Gas turbine exhaust temperature block parameter ($^{\circ}$ F)	550
A_{f2}	Gas turbine torque block parameter	-0.3
B_{f2}	Gas turbine torque block parameter	1.3
C_{f2}	Gas turbine torque block parameter	0.5
T_R	Rated temperature ($^{\circ}$ F)	972
K_6	Minimum fuel flow	0.23
T_C	Rated exhaust temperature ($^{\circ}$ F)	838

The IEEE1 Model

The IEEE1 governor-turbine model is an alternative model for steam turbine generators. This model is used to model the steam turbine component of CCGTs and inhibits a very fast response time. A block diagram representation of this model is outlined in Figure 9.3, with the associated parameters outlined in Table 9.4.

Figure 9.4 – IEEE1 Governor-Turbine Model

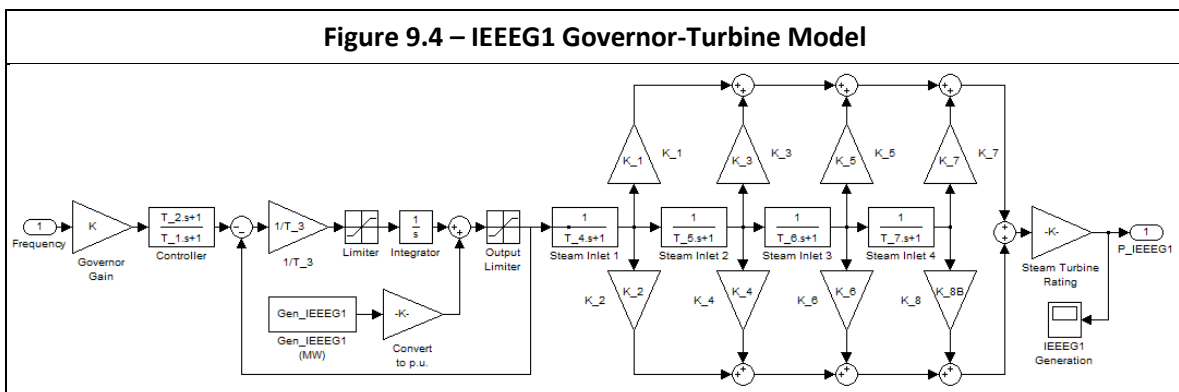

Table 9.4 – IEEE1 Model Parameters

Parameter	Description	Value
K	Inverse of governor droop	22
T ₁	Controller time-constant (s)	0
T ₂	Controller lead time compensation	0
T ₃	Constant gain	0.15
T ₄	Steam inlet 1 time-constant (s)	0.4
K ₁	Constant gain	1
K ₂	Constant gain	0
T ₅	Steam inlet 2 time-constant (s)	0
K ₃	Constant gain	0
K ₄	Constant gain	0
T ₆	Steam inlet 3 time-constant (s)	0
K ₅	Constant gain	0
K ₆	Constant gain	0
T ₇	Steam inlet 4 time-constant (s)	0
K ₇	Constant gain	0
K ₈	Constant gain	0

10) CALIBRATING THE SYSTEM FREQUENCY MODEL

10.1) BENCHMARKING AGAINST HISTORIC EVENTS

Using the system frequency and generation dispatch data corresponding with past generator tripping events provided by Western Power, ROAM has benchmarked the system frequency model against several cases.

10.1.1) Contingency 1

The contingency event occurred on 13 September 2010 at 5:59:20 AM 2009, and involved tripping of a single unit of a coal-fired generator, which resulted in a loss of 150MW in the overall system supply. The system load at the time was around 1,720MW. From the historic system data provided by Western Power, ROAM approximated the system inertia provided by active generators immediately after the unit went offline to be around 12,529MWs. Furthermore, ROAM also derived the most likely responsive generation mix (grouped by the governor-turbine type) to

arrest the frequency decline immediately after 150MW of supply was lost. This is summarised in Table 10.1 and was used in ROAM’s model to simulate the system frequency response. Figure 10.1 is a comparison between the simulated frequency response and the actual system frequency.

Governor-Turbine Type	Generation (MW)	Capacity (MW)
IEESGO (Slow)	699.1	1295
IEESGO (Fast)	0	0
GAST2A	225.7	351
IEEEG1	0	0

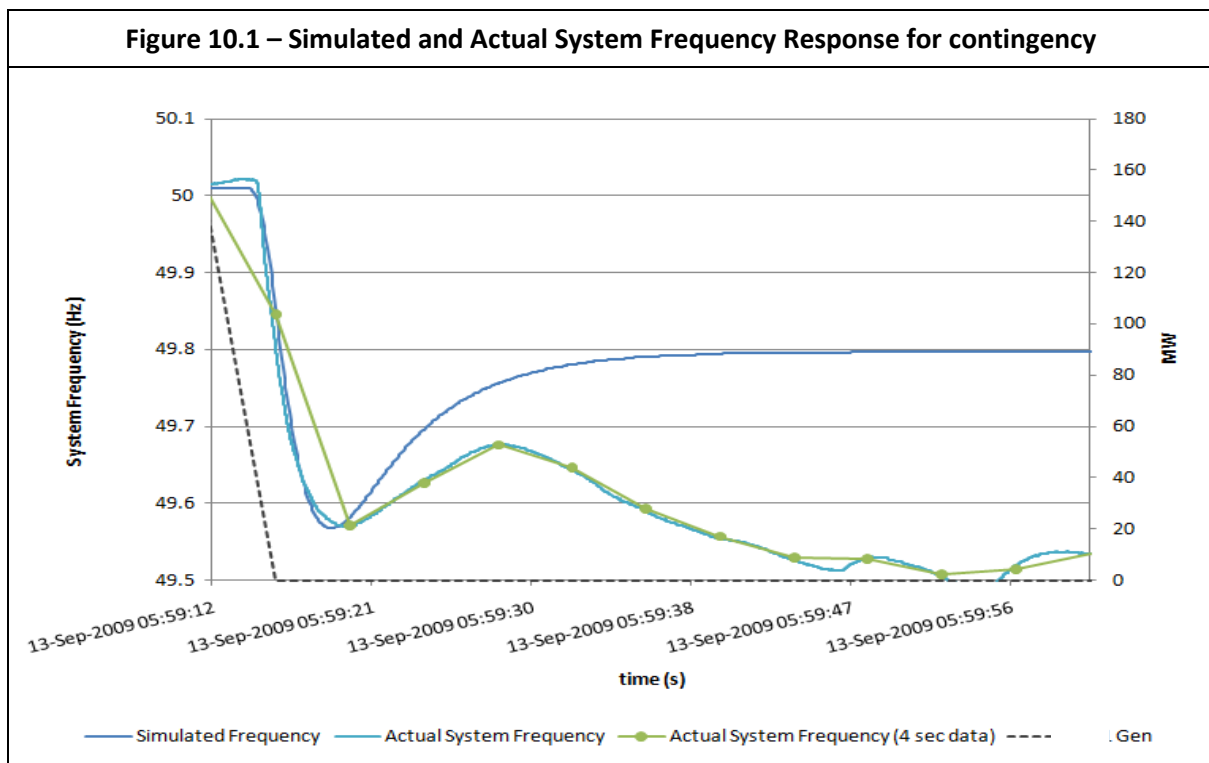

It can be observed from Figure 10.1 that the simulated system frequency closely aligns with the actual system frequency within 8 seconds immediately after the contingency. This indicates a similar rate of change in frequency decay between ROAM’s system model and the SWIS system, which justified the applied system inertia. Furthermore, the frequency bottoming out at around 49.57Hz also conforms to the observed system frequency. This indicates a similar amount of governor response was present at the time of contingency in ROAM’s system model and the SWIS system. The agreement of the two frequency responses, however, starts to disappear beyond 8 seconds. ROAM believes that this is due to a large number of factors which was not captured in ROAM’s model. These include generators detuning their governors, generators pulling back or shutting off due to excessive generation and/or over heating (as suggested by the second decline

in frequency observed 16 seconds after the contingency) and external factors such as instructions given by the operators. Having said that, these factors are difficult to model and considered to be long-term effects. ROAM believes that for the purpose of assessing system frequency response with varying intermittent generation levels, the focus should be on how the frequency varies with fast varying disturbance introduced by intermittent generation, and the long-term effects outline above can be considered to have a small impact on the modelling outcome.

10.1.2) Contingency 2

This contingency event occurred on 12 November 2010 12:16:32 PM 2009 involved tripping of a unit of a coal-fired generator, which resulted in a lost of 211MW in the overall system supply. The system load at the time was around 2,500MW. From the historic system data provided by Western Power, ROAM approximated the system inertia provided by the active generators (tripped unit excluded) to be around 14,345MWs. Furthermore, ROAM also derived the most likely responsive generation mix (grouped by the governor-turbine type) to arrest the frequency decline immediately after 211MW of supply was lost. This is summarised in Table 10.2 and was used in ROAM's model to simulate the system frequency response. Figure 10.2 is a comparison between the simulated frequency response and the actual system frequency.

Table 10.2 – SWIS Generation Dispatch of Responsive Generators		
Governor-Turbine Type	Generation (MW)	Capacity (MW)
IEESGO (Slow)	1081.1	1231
IEESGO (Fast)	0	0
GAST2A	289.6	475.4
IEEEG1	0	0

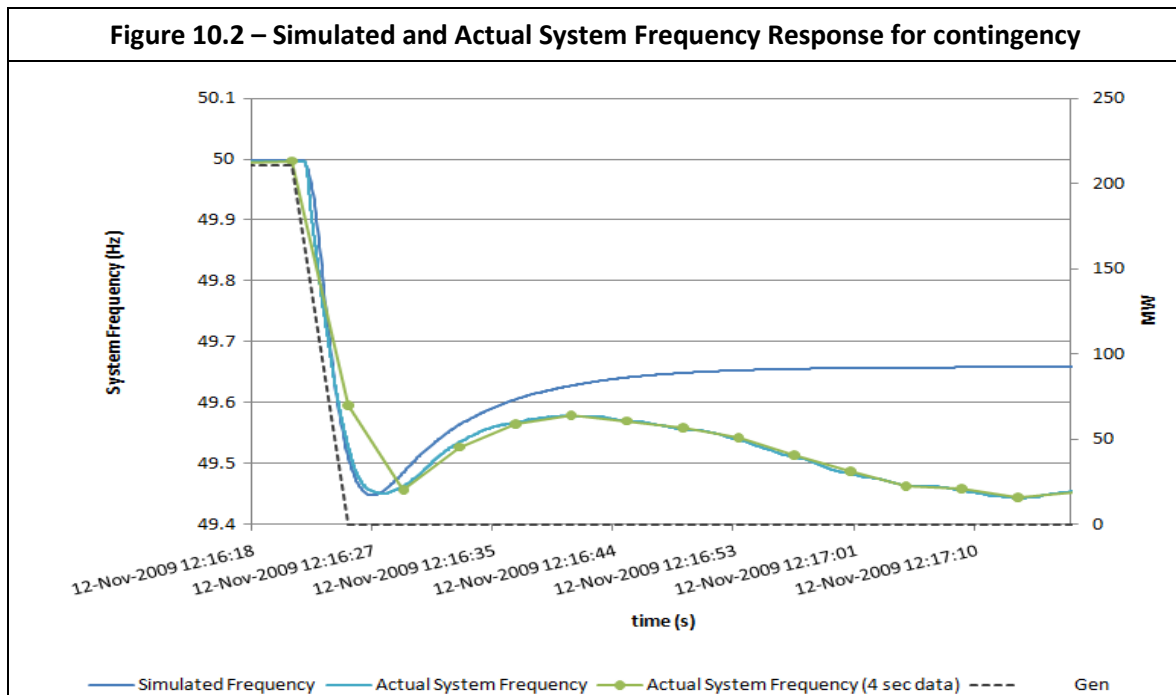

Similar to the simulation outcome for the first contingency discussed in the previous section, it can be observed from Figure 10.1 that the simulated system frequency closely aligns with the actual system frequency within 8 seconds immediately after the unit trips. This again indicates similar rate of change in frequency decay between ROAM's system model and the SWIS system, which justified the applied system inertia. Furthermore, the frequency bottoming out at around 49.46Hz also conforms to the observed system frequency. For periods beyond 8 seconds, the agreement in frequency starts to disappear due to similar reasoning discussed earlier for the first contingency event.

11) FAST RESPONSE REQUIREMENTS - FREQUENCY MODELLING

As outlined in the previous sections of this report, short term system frequency fluctuations depend heavily on the system inertia, the magnitude of the imbalance between power generation and consumption, and the amount of generation available provided by governor responsive generating units.

Having determined the Fast Response Service requirements for each of the four scenarios outlined in Table 7.6 to Table 7.9, these requirements were applied to the system frequency model at different load conditions with appropriate assignment of system inertia and governor responsive units to model the short-term system frequency fluctuations.

11.1) SYSTEM LOAD AND INERTIA

The system loading condition can vary significantly throughout the day. Therefore, different system loading conditions were considered for each of the four scenarios to reflect different system dispatch levels and subsequently different system inertia. In particular, minimum, intermediate and maximum loads based on forecasts provided by the IMO and Western Power were employed. This is outlined in Table 11.1.

	Scenario 1			Scenario 2			Scenario 3			Scenario 4		
	Min.	Int.	Max.	Min.	Int.	Max.	Min.	Int.	Max.	Min.	Int.	Max.
2009-10	1,306	2,727	4,148	1,306	2,753	4,200	1,306	2,727	4,148	1,306	2,795	4,283
2014-15	1,804	3,593	5,381	1,804	3,661	5,518	1,804	3,593	5,381	1,804	3,761	5,718
2019-20	1,974	4,101	6,229	1,974	4,185	6,396	1,974	4,101	6,229	1,974	4,361	6,749
2024-25	2,153	4,561	6,969	2,153	4,684	7,216	2,153	4,561	6,969	2,153	4,943	7,734
2029-30	2,348	5,028	7,709	2,348	5,192	8,036	2,348	5,028	7,709	2,348	5,533	8,719

The system loads were then translated into the appropriate generation dispatch outlined in Table D.1 in the Appendix based on the dispatch merit order outlined in Table C.1 in the Appendix. With the inertia data of existing generation units provided by Western Power, the system inertia associated with each loading condition was derived and is summarised in Table 11.2.

	Scenario 1			Scenario 2			Scenario 3			Scenario 4		
	Min.	Int.	Max.	Min.	Int.	Max.	Min.	Int.	Max.	Min.	Int.	Max.
2009-10	7,004	12,392	16,647	7,004	12,392	17,725	7,004	12,392	16,647	7,004	12,392	17,725
2014-15	6,435	17,592	21,764	8,404	15,728	23,878	7,756	15,619	22,905	8,404	15,728	25,367
2019-20	5,968	20,588	25,922	8,404	17,080	28,811	6,444	18,505	25,015	7,784	17,881	31,202
2024-25	5,475	22,802	29,382	7,935	20,628	32,247	5,608	20,785	27,435	7,518	20,797	35,721
2029-30	5,929	26,080	30,385	7,731	24,499	35,356	4,955	24,262	28,567	7,057	23,078	39,800

Note that assumed generator inertia values were applied for new entry plants based on similar units currently existing in the SWIS.

11.2) ASSIGNMENT OF GOVERNOR RESPONSIVE UNITS

The assignment of governor responsive units was based on the list of plants providing load following (see Table D.1 in the Appendix), which was assumed to have the highest dispatch order

with different unit availabilities subject to the planting schedule outlined for each scenario. Generation units providing load following are assumed to dispatch at the mid-point of their respective minimum and maximum loads. Table 11.3 outlines the total generator dispatch and capacity of units offering governor response modelled for different years and scenarios.

	Scenario 1			Scenario 2			Scenario 3			Scenario 4		
	Min.	Dispatch	Capacity	Min.	Dispatch	Capacity	Min.	Dispatch	Capacity	Min.	Dispatch	Capacity
2009-10	70	155	239	70	155	239	70	155	239	70	155	239
2014-15	194	460	718	114	282	423	121	285	448	119	282	439
2019-20	202	477	747	130	307	483	164	386	608	119	282	439
2024-25	207	486	766	130	307	483	160	377	593	150	357	555
2029-30	247	580	913	190	446	703	187	440	693	160	381	593

11.3) FREQUENCY MODELLING RESULTS

The Fast Response requirements for each year and scenario were modelled as a linear ramp from zero to the fast response requirement values (both positive and negative) over a one minute interval added on top of the total system generation. Simulation outcomes are outlined in Table 11.4.

Scenario 1						
	Min. Load		Intermediate Load		Max. Load	
	Min.	Max.	Min.	Max.	Min.	Max.
2009-10	49.83	50.17	49.88	50.13	49.90	50.10
2014-15	49.85	50.15	49.87	50.13	49.89	50.11
2019-20	49.84	50.16	49.87	50.13	49.88	50.12
2024-25	49.82	50.18	49.85	50.15	49.88	50.13
2029-30	49.82	50.18	49.85	50.15	49.88	50.13
Scenario 2						
	Min. Load		Intermediate Load		Max. Load	
	Min.	Max.	Min.	Max.	Min.	Max.
2009-10	49.84	50.18	49.88	50.13	49.90	50.10
2014-15	49.83	50.17	49.82	50.14	49.89	50.11
2019-20	49.82	50.18	49.84	50.17	49.89	50.12

2024-25	49.79	50.22	49.84	50.17	49.87	50.13
2029-30	49.82	50.19	49.86	50.15	49.88	50.12
Scenario 3						
	Min. Load		Intermediate Load		Max. Load	
	Min.	Max.	Min.	Max.	Min.	Max.
2009-10	49.83	50.18	49.88	50.13	49.90	50.10
2014-15	49.84	50.16	49.87	50.13	49.89	50.11
2019-20	49.84	50.15	49.87	50.13	49.89	50.11
2024-25	49.80	50.20	49.84	50.16	49.87	50.13
2029-30	49.80	50.21	49.84	50.17	49.87	50.14
Scenario 4						
	Min. Load		Intermediate Load		Max. Load	
	Min.	Max.	Min.	Max.	Min.	Max.
2009-10	49.83	50.18	49.88	50.13	49.90	50.10
2014-15	49.84	50.16	49.87	50.13	49.90	50.11
2019-20	49.82	50.19	49.86	50.14	49.89	50.11
2024-25	49.82	50.18	49.86	50.14	49.88	50.12
2029-30	49.81	50.20	49.86	50.15	49.89	50.12

It can be observed from Table 11.4 that provided that the assumptions made for system load, system inertia and governor responsive units can be met, the short-term frequency fluctuation is expected to be within 49.8Hz to 50.2Hz for all years and scenarios, with the exception of Scenario 2 in 2024-25 and Scenario 3 in 2029-30.

To ensure that the frequency is kept within 49.8Hz to 50.2Hz for the cases outlined above, an increase in the amount of governor response available is required. Further simulation with incremental increase in governor response indicate additional capacity of 60MW and 40MW of governor response above that provided by load following plant calculated earlier in this report is required keep the frequency within the desired bands for Scenario 2 and Scenario 3 in 2024-25 and 2029-30, respectively.

Alternatively, the frequency excursions can also be reduced by increasing the system inertia. This can be achieved by dispatching more generating units at minimum load, inertial response contribution from wind generators, and even the possibility of introducing devices dedicated to providing inertia. Further simulation of Scenario 2 in 2024-25 with increase in system inertia indicated that the system inertia needs to be increased significantly (from 7,935 MWs to 17,800 MWs) to keep the frequency within 49.8Hz to 50.2Hz.

Comparing the two approaches outlined above to ensure acceptable frequency excursions, an additional 60MW capacity increase in governor response seems more favourable than increasing the system inertia since:

- Dispatching more units at minimum load may not be possible at low demand periods due to insufficient demand;
- Inertial response from wind generators can be limited depending on the turbine technology available²⁷; and
- Increasing the system inertial by 2-fold overall will be expensive but is only utilised on rare occasions.

These results suggest that if the existing definition for load following is used to allocate load following plant based on a 30min rolling average, the fast response service can be provided to a sufficient level through the governor response of those units. No additional governor response is required, and system inertia does not become an issue.

12) ISSUES ASSOCIATED WITH PROVISION OF ANCILLARY SERVICES

Verve plant available for providing load following is listed in Table D.1 in the appendix. The Pinjar Frame 9 units are utilised first, until the new LMS100 units are available, in which case they are used in preference. If more load following is required the smaller Pinjar Frame 6 units are then dispatched, followed by the Mungarra units.

In order to provide the maximum amount of load following, plant must be dispatched to a mid-point between minimum and maximum load. This gives the maximum room for movement to control the frequency. This means that in order to provide 66 MW of load following (in 2009-10 in Scenario 1, for example), 155 MW of load following plant must be dispatched (Pinjar GT11 and Pinjar GT10). The corresponding amounts of load following plant dispatched for each year for Scenario 1 are listed in Table 12.1.

The minimum load in each year is also listed in Table 12.1. These take into account the large block loads currently under development, including Boddington Gold Mine, Extension Hill Magnetite, Gindalbie, Grange Resources and the Desal 2 plant, with appropriate years of entry.

²⁷ J. Ekanayake and N. Jenkins, Comparison of the Response of Dugly Fed and Fixed-Speed Induction Generator Wind Turbines to Changes in Network Frequency, IEEE Transactions on Energy Conversion, Vol. 19, No. 4, December 2004.

Table 12.1 – Minimum load compared with load following requirement (Scenario 1)

	Minimum load (MW)	Load following required (MW)	Load following plant dispatched (MW)
2009-10	1,306	66	155
2010-11	1,407	68	155
2011-12	1,417	72	127
2012-13	1,656	141	282
2013-14	1,770	141	282
2014-15	1,804	249	453
2015-16	1,838	250	453
2016-17	1,872	250	453
2017-18	1,906	251	453
2018-19	1,940	254	453
2019-20	1,974	255	477
2020-21	2,008	276	501
2021-22	2,043	276	501
2022-23	2,079	277	501
2023-24	2,116	277	501
2024-25	2,153	278	501
2025-26	2,190	278	501
2026-27	2,229	288	525
2027-28	2,268	289	525
2028-29	2,307	289	525
2029-30	2,348	299	548
2030-31	2,389	300	548

It is assumed that the minimum load of cogeneration plant will be dispatched ahead of wind generation, being considered "must-run". Plant required for ancillary services (load following and spinning reserve) will be dispatched next, being necessary for frequency control. For this analysis it is assumed that Collie is operating at minimum load overnight (160 MW). The spinning reserve requirement in that period is then 70% of this capacity (112 MW), which can be provided by load following plant. In 2009-10 an additional 46 MW of spinning reserve is required overnight, in addition to the 66 MW of load following plant. By 2012-13 no additional plant is required for spinning reserve in excess of the load following plant.

Figure 12.1 shows a comparison of the forecast minimum load in each year compared with the aggregate of cogeneration minimum loads, load following plant and spinning reserve plant. The total capacity of installed wind is illustrated in stacked form above these amounts. Note that the aggregate installed wind will almost never operate at 100% capacity (this would require all installed wind farms to be operating at 100% simultaneously), so this figure does not illustrate a dispatch order; it is simply an illustration of the installed capacity of wind relative to other factors.

In 2020-21 the installed wind capacity (plus cogeneration and ancillary services capacity) exceeds the minimum load. In the exceedingly rare circumstance that all installed wind farms were operating close to maximum capacity at the time of minimum load, this would mean that one or both of the following would need to occur to manage the system:

- Some (or all) wind farms would need to be curtailed
- Some (or all) large thermal plants would need to be shut down.

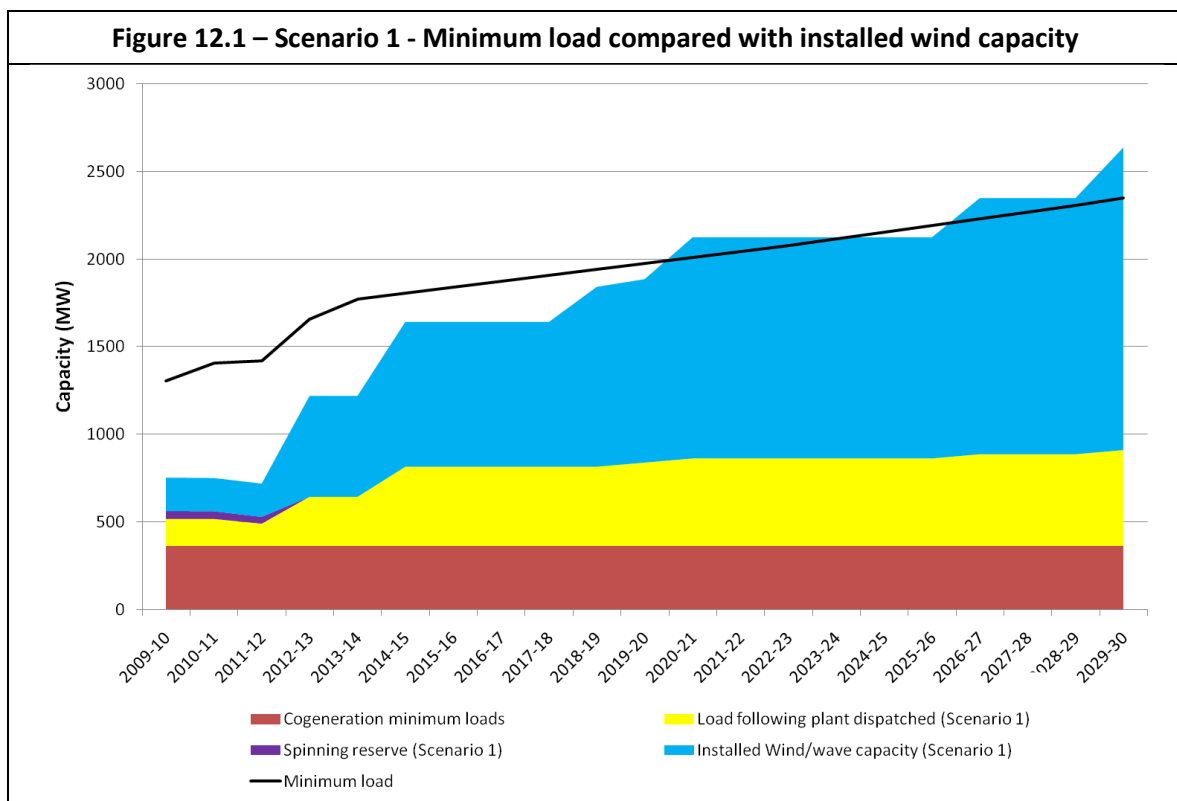

Importantly, the minimum loads illustrated here are annual minimums, meaning that the load is only forecast to be this low on one evening of the year. All other overnight troughs will have higher loads. In addition, due to geographical diversity of wind farms it will be a rare event to approach 100% output of all wind farms simultaneously. It is even more exceedingly unlikely that this event will occur at time of minimum load.

Note that the aggregate minimum loads of all large thermal plants in the SWIS combined with load following plant and minimum loads of cogeneration plant already exceeds the minimum load. This means that shut down of some large thermal plant is already necessary for management of the system during extreme overnight troughs.

This overnight load forecast does not include any further overnight block loads beyond 2-3 years. Industrial developments could therefore raise this overnight load estimate. In addition, Scenario 1 represents a very high level of wind penetration; Scenarios 2-4 are less extreme, as illustrated in the figures below.

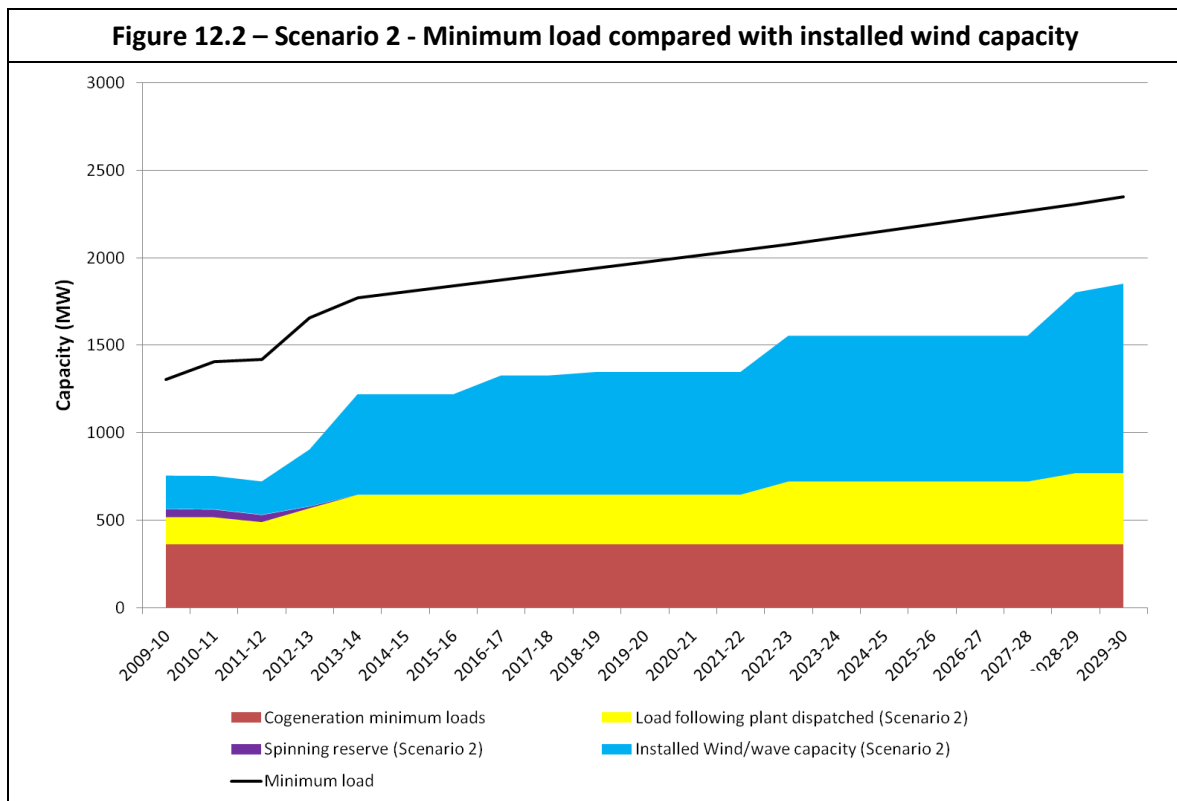

Figure 12.3 – Scenario 3 - Minimum load compared with installed wind capacity

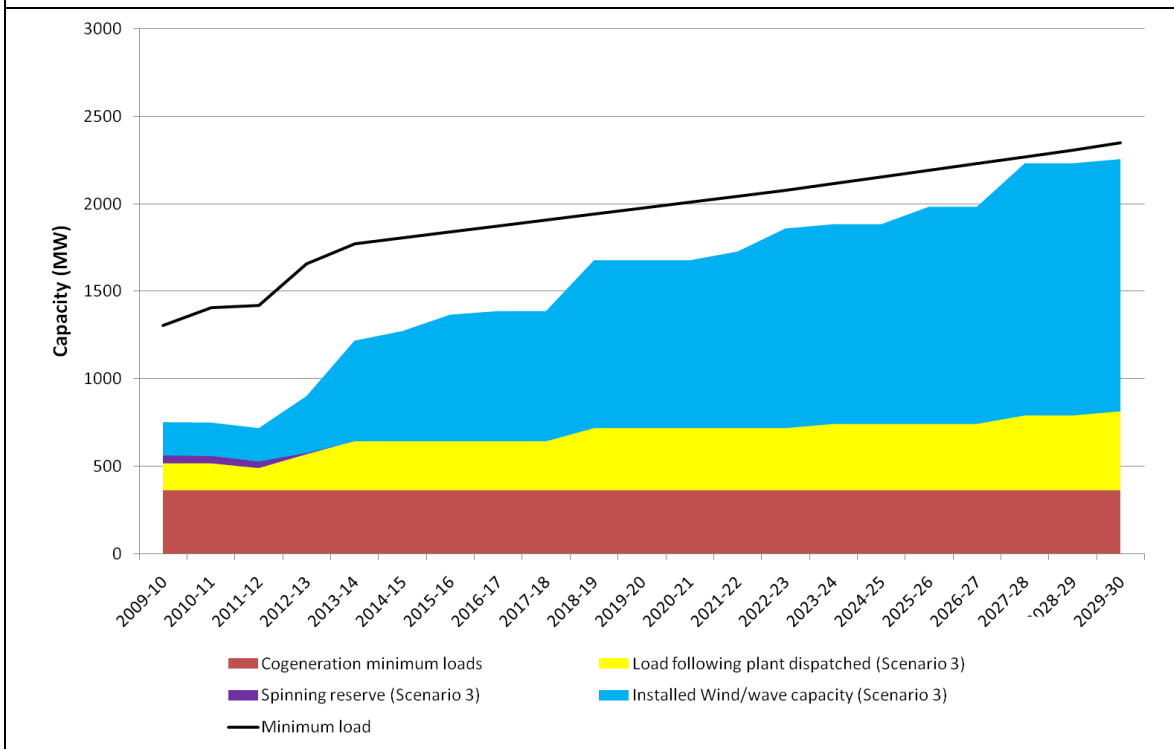
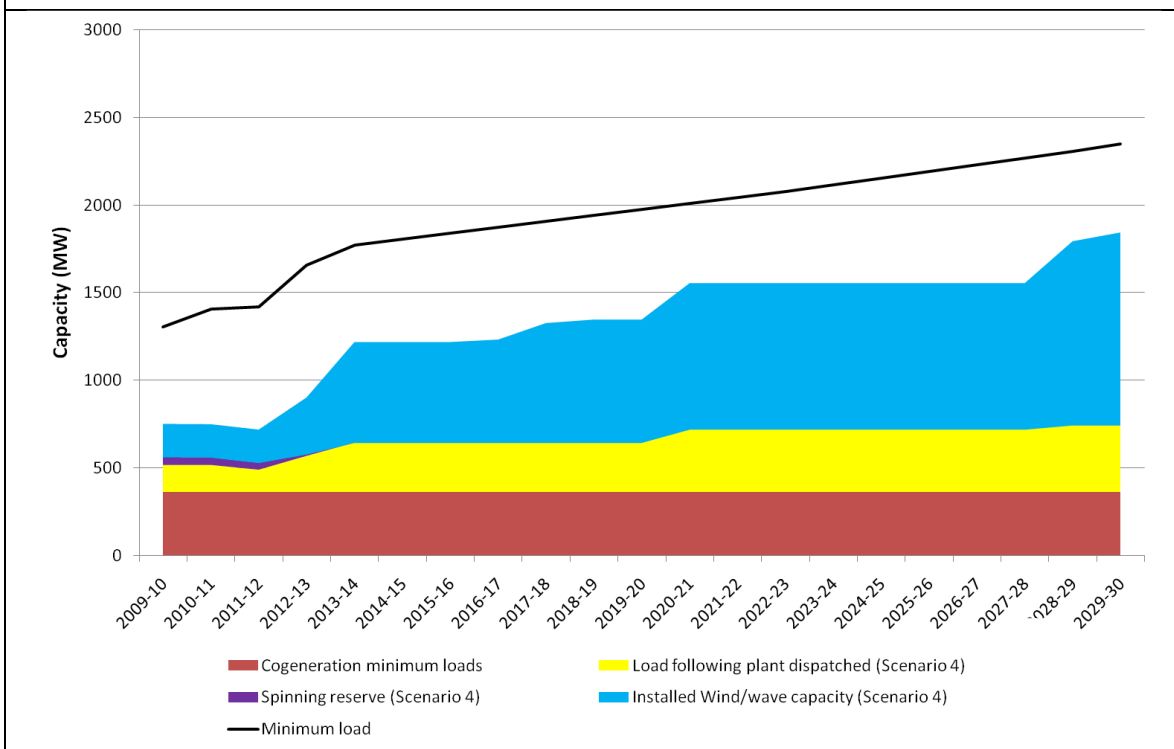

Figure 12.4 – Scenario 4 - Minimum load compared with installed wind capacity



Curtailment of wind farm generation

In the absence of a carbon price, coal-fired generation could argue that they should be dispatched to minimum loads ahead of wind generation, due to the costs associated with start-up and shut down. The minimum loads of the existing large thermal plants in the SWIS sum to close to 1000 MW, and the new large thermal plants considered in this study (installed mostly in Scenario 4) add an additional 415 MW. As illustrated in the figures above, this would involve curtailment of wind generation during overnight periods in the rare event that the aggregate system wind was operating close to full capacity during a minimum load period.

Coal-fired generation

If the existing rules are maintained, and wind farms are dispatched ahead of all generation except cogeneration (being "must-run" plant) and plant required for ancillary services (load following and spinning reserve), then some coal-fired generation will need to be cycled on a daily basis (daily start-up and shut-down). The cost and feasibility of two-shifting operation varies widely from plant to plant, and needs to be assessed on an individual basis. However, particularly for new plant the costs associated with wear and tear on parts can be very substantial. System security may also be adversely affected due to delayed unit return to service. It is advised that dispatch merit order priorities are analysed on this basis.

Impact of a carbon price

If a carbon price is introduced the cost of meeting the liability for carbon credits for coal-fired generation operating at minimum load overnight may be larger than the cost of an overnight shut-down/start-up cycle. This would incentivise coal-fired generation to two-shift, allowing wind generation to be dispatched ahead of the minimum loads of coal-fired plant. The carbon price necessary to produce this effect will vary substantially from plant to plant, but will generally be lower for older plant (due to the lower costs associated with start-up/shut-down).

13) EXPERIENCES IN OTHER MARKETS

It is useful to consider the experiences of wind integration into other markets, to determine what problems were significant, and how they have been dealt with. This section provides an overview of issues surrounding frequency control ancillary services in other markets related to wind integration.

Germany and Denmark are included, since these systems have the highest levels of wind penetration in the world. Germany has the largest total installed capacity of wind generation, and areas of Denmark have the highest level of penetration compared with the local load.

Both Germany and Denmark are highly interconnected with surrounding countries, which bears little resemblance to the isolated grid in the SWIS. Since the degree of interconnection is very important for wind integration, several more isolated markets with lower levels of wind penetration are also discussed.

13.1) MARKETS WITH SIGNIFICANT INTERCONNECTION

13.1.1) Germany

Germany had 24 GW of installed wind generation capacity by the end of 2008²⁸. By comparison, the peak system demand is approximately 75 GW. The system is very strongly interconnected with neighbouring countries, including Denmark, The Netherlands, Sweden, Czech Republic and Austria. These connections are utilised for balancing.

Germany has implemented specific requirements for wind farms since 2003. These requirements are similar to those in Denmark, and include requiring wind farms to be able to assist with network frequency control. Wind forecasting is also an important part of system management, being conducted at a regional level, and allowing system operators to manage wind generation in the same way as load variation. Forecast errors of 10% for 24 hour ahead forecasts are achieved.

Significant transmission upgrades have also been implemented to support wind development, and further reinforcement and extension of the grid are preconditions for achieving the envisaged wind power development in Germany. Studies have cautioned that this transmission development could be stymied by the planning and legal authorisation process²⁹.

13.1.2) Denmark

Denmark has an installed wind capacity in excess of 3000 MW, equivalent to 30% of the total installed capacity in the country. Additionally, around 20% of the installed generation is non-dispatchable combined heat and power, creating additional challenges for balancing supply and demand.

The majority of the wind in Denmark is installed in the western part of the country (more than 2300 MW). This grid has a maximum demand of approximately 4000 MW, and is very strongly interconnected, with 2800 MW of interconnection capacity to Germany, Norway and Sweden.

The high degree of interconnection has been instrumental in allowing this high penetration of wind generation, since Denmark obtains much of their balancing services via the interconnectors. More recently, this strategy of obtaining ancillary services internationally has become problematic, and has been identified as a threat to system security. Interconnector limits and a lack of ability to export energy at times of peak generation has caused concern about thermal overload.

Denmark is therefore working to provide a greater level of ancillary services and control domestically. The ability to regulate interconnector flows by disconnecting wind farms if necessary has been introduced, in addition to upgrading of various network components to

²⁸ German WindEnergy Association (BWE), "Wind Energy in Germany". <http://www.wind-energie.de/en/wind-energy-in-germany/>

²⁹ Deutsche Energie-Agentur, "Energy Planning for the Integration of Wind Energy in Germany on Land and Offshore into the Electricity Grid". 24 Feb 2005.

increase their overload capacities³⁰. Wind penetration has also been managed through a significant focus on wind forecasting to assist balancing.

Turbines in Denmark are generally in small clusters of 10-20 MW, widely dispersed around the country. About 93% of the wind generation is fed into the distribution network (as opposed to being transmission connected). This high level of geographical distribution of the turbines (rather than clustering of turbines in a small number of large wind farms) decreases the volatility of the aggregate wind generation, allowing a lower level of plant required to provide load following.

13.2) MARKETS WITH LOW INTERCONNECTION

13.2.1) South Australia (NEM)

There is substantial interest in wind development in South Australia, due to the availability of an excellent wind resource. 740 MW of wind capacity is currently installed, which is substantial compared to a minimum load of approximately 1000 MW. The Planning Council is currently tracking an additional 5000 MW of proposed projects, some of which are close to realisation, and others of which will require additional network development³¹. The locations of the installed and proposed wind farms are illustrated in Figure 13.1.

³⁰ Garrad Hassan Pacific, "Review of Impacts of High Wind Penetration in Electricity Networks", March 2005.

³¹ Electricity Supply Industry Planning Council (ESIPC), Annual Planning Report, June 2009.

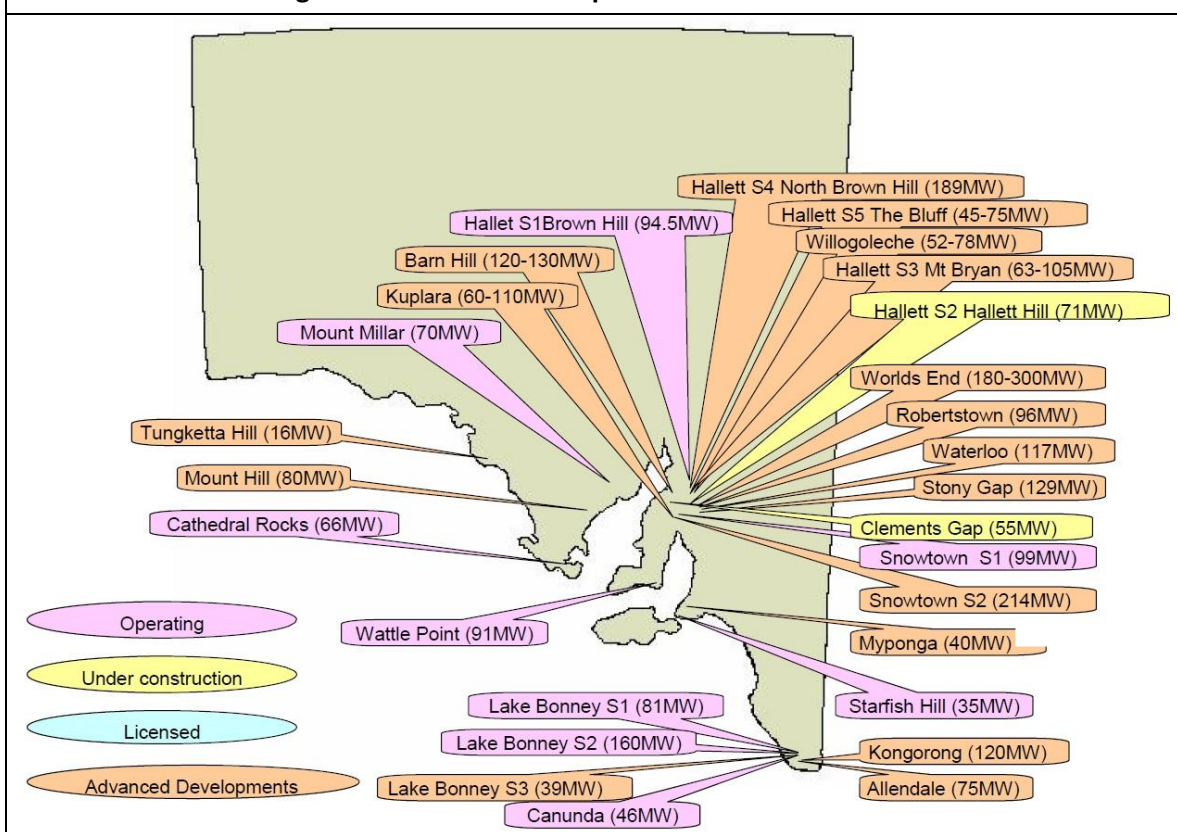
Figure 13.1 – Wind development in South Australia³²

South Australia has limited interconnection capacity, being connected only to Victoria in the NEM (National Electricity Market) via Heywood (import limit 460 MW, export limit 300 MW) and Murraylink (bidirectional nominal limit 220 MW). The actual capacity of the interconnectors depends upon a variety of system conditions (particularly, the import limit on Heywood is significantly smaller during peak demand periods). A number of potential upgrades to Heywood are currently being analysed. The limited interconnection of South Australia to the NEM creates additional challenges for the integration of wind.

To manage the integration of wind energy into South Australia, a new category for registration of intermittent generators was recently approved. This new category is called "semi-scheduled", and allows the output of generators in this category to be optimised during periods when constraints in which they are included are binding. Prior to the introduction of this category, it was necessary for new wind farms in South Australia to register as "scheduled" generators to provide sufficient control to system operators to maintain system security.

South Australia has been conducting analysis into the expected variability of wind output in South Australia. Benefits from geographical diversity are found to be substantial in reducing variability³³.

³² Electricity Supply Industry Planning Council (ESIPC), Annual Planning Report, June 2009.

³³ Electricity Supply Industry Planning Council (ESIPC), Annual Planning Report, June 2009.

Frequency control ancillary services

Frequency control ancillary services (FCAS) in South Australia are operated through the NEM via a complex competitive market. Eight separate markets³⁴ are operated to provide the necessary frequency control services:

1. Regulation
 - a. Raise and lower
2. Contingency
 - a. Fast raise and fast lower (6 second response)
 - b. Slow raise and slow lower (60 second response)
 - c. Delayed raise and delayed lower (5 minute response)

Each of these may be provided by a different market participant, depending upon their individual characteristics. Participants submit bids for each service for each dispatch interval, via NEMMCO's market management systems. NEMMCO's dispatch engine then co-optimises the dispatch in each interval to ensure that sufficient frequency control services of each type are provided in the most economic way possible.

This dispatch process occurs every 5 minutes, so only wind shifts within this interval affect FCAS provision. Wind shifts within 5 minutes are likely to be very small compared with the deviation from a 30 minute average measured from 45 to 15 minutes ago (as is current practice in the SWIS). This 5 minute dispatch interval substantially limits load following requirements.

NEMMCO has indicated that intermittent generation is likely to increase the variability of the "apparent demand" in the NEM. They suggest that this effect is likely to increase the cost to the market of procuring FCAS³⁵. A robust and competitive ancillary services market undoubtedly contributes to minimising this cost.

Australian Wind Energy Forecasting System (AWEFS)

AEMO uses the AWEFS tool to forecasting wind generation on short term timescales. The system, sourced from the ANEMOS consortium in the EU, became operation in September 2008, and is integrated into dispatch and supply/demand balancing processes in the NEM.

ANEMOS combines two broad approaches to determine a wind forecast³⁶:

1. Statistical approach - uses historical data (power and wind measurements) and numerical weather predictions
2. Physical approach - applies the physical laws of the generating plant, such as terrain information, geographical coordinates etc.

³⁴ Guide to Ancillary Services in the National Electricity Market, Australian Energy Market Operator (AEMO), 25/08/2009.

³⁵ NEMMCO, "Intermittent Generation in the National Electricity Market", 18 March 2003.

³⁶ <http://www.aemo.com.au/electricityops/awefs.html>

The AEWFS tool is used over a variety of timescales, including for 5min dispatch, 5min Pre-dispatch (2hrs ahead), Pre-Dispatch (40 hrs ahead), 6 day reserve forecast, and for the two year MT PASA reserve forecast.

The AWEFS system is used in dispatch in conjunction with the bids of semi-scheduled wind farms. Wind farms submit offers and plant availability. The AWEFS system wind forecasts are then used to determine the loading (dispatch) instructions to the wind farm from AEMO, in competition with other generators in the economic dispatch algorithm. Wind farm output can be limited (curtailed) when required to maintain system security.

Market participants and AEMO can input their own forecasts for wind farms via a "Forecast Override Interface" if required for all NEM timeframes except Dispatch.

13.2.2) EIRE (Republic of Ireland)

The Republic of Ireland (ROI) has a peak demand of approximately 5,000 MW³⁷. Currently, there is 912 MW of installed wind capacity³⁸, with an announced target of sourcing 40% of electricity from renewable sources by 2020. This has been projected to require a total of 4,600 MW of wind to be installed by 2020. By this time it is projected that the grid will have a minimum load of 3,500 MW and a maximum load of 9,600 MW³⁹.

The Republic of Ireland is weakly interconnected. There are two interconnections to Northern Ireland utilised only as standby connections in the case of an unexpected outage, and one main interconnection with a firm capacity of 600 MW. The Northern Ireland system is further connected to Scotland via a DC link with a capacity of 400 MW.

The Republic of Ireland has implemented a number of measures to manage wind penetration. In December 2003 a temporary moratorium was imposed, preventing the granting of any new connections for wind farms beyond those already agreed. This allowed time to implement necessary market changes and determine an appropriate Grid Code specifically for wind farms.

Under the trading arrangements in Ireland, wind farms can opt to be fully dispatchable (and hence participate in the market like any other generator), or to be centrally controllable (allowing the system operator to curtail wind farm output when required). If the plant chooses to be centrally controlled, they are paid the market floor price. In either case, wind farms can be effectively controlled by the system operator, allowing system security to be maintained.

In Ireland, wind farms are required to be able to provide a frequency response through active power control. If implemented, this involves curtailing the wind farm output. Wind farms are

³⁷ EirGrid, Generation Adequacy Report 2010-2016, released 2009.

³⁸ EirGrid, Annual Report 2008.

³⁹ S. Twhig, K. Burge, sC. Nabe, A. Crowe, K. Polaski and M. O'Malley. "Ultra High Wind Energy Penetration in an Isolated Market". IEEE 2008.

also required to adhere to two ramp rate limits, one applied to one minute ramps, the other to an average ramp over 10 minutes. Both ramp rate limits can be changed by the system operator as required, with two week's notice⁴⁰.

Wind forecasting is also an important element of system management in Ireland, allowing secure and economic operation.

It has been suggested that capacity payments to conventional generators are important to ensure that there is sufficient base load and peaking conventional plant available in the ROI grid to provide system security. These should be weighted towards fixed payments (rather than variable payments) to ensure that peaking generation remains profitable⁴¹.

The importance of developing an active ancillary services market to manage extensive wind penetration into the ROI grid has also been emphasised. Currently ancillary services are procured by contract only, which is limited in terms of price signals and transparency⁴².

14) COSTS OF ANCILLARY SERVICES

14.1) EXISTING RULES FOR FUNDING OF LOAD FOLLOWING

In the existing system, the IMO recovers the costs of the ancillary services from Market Participants through the wholesale market settlement systems, and uses the revenue received to fund Ancillary Services provided by the Electricity Generation Corporation (Verve) and contracted Ancillary Service providers.

Western Power publishes annual reports outlining the costs of providing ancillary services to the SWIS⁴³. Currently, costs are calculated by System Management in two parts - a Capacity cost and an Availability cost. Both are calculated according to detailed formulas involving many parameters including the Marginal Cost Administered Price (MCAP), determined two business days after the relevant trading day. These equations are listed below, as detailed in the SWIS Market Rules.

⁴⁰ EirGrid, EirGrid Grid Code, Version 3.4, Effective Oct 16th 2009.

⁴¹ S. Twohig, K. Burge, sC. Nabe, A. Crowe, K. Polaski and M. O'Malley. "Ultra High Wind Energy Penetration in an Isolated Market". IEEE 2008.

⁴² S. Twohig, K. Burge, sC. Nabe, A. Crowe, K. Polaski and M. O'Malley. "Ultra High Wind Energy Penetration in an Isolated Market". IEEE 2008.

⁴³ Ancillary Service Report 2009 prepared under clause 3.11.11 of the Market Rules by System Management - 28 May 2009. Western Power.

14.2) EXISTING CALCULATION OF LOAD FOLLOWING COSTS

The cost of providing the load following service as defined in the SWIS rules is composed of a capacity cost, and an availability cost, as outlined in the WEM Rules clause 3.13.1.

3.13.1. The total payments by the IMO on behalf of System Management for Ancillary Services in accordance with Chapter 9 comprise:

(a) [Blank]

(aA) for Load Following Service for each Trading Month:

- i. a capacity payment $Capacity_{LF}$ calculated as;

 - 1. the Monthly Reserve Capacity Price in that Trading Month;*
 - 2. multiplied by LFR, the capacity necessary to meet the Ancillary Service Requirement for Load Following in that month;**
- ii. an availability payment $Availability_{Cost_{LF}}(m)$ calculated in accordance with clause 9.9.2(d) for that Trading Month;*
- (b) an amount $Availability_{Cost_{R}}(m)$ for Spinning Reserve for each Trading Month, which is calculated in accordance with clause 9.9.2(c) for that Trading Month; and*
- (c) $Cost_{LRD}$, the monthly amount for Load Rejection Reserve and System Restart, determined in accordance with the process described in clause 3.13.3B and 3.13.3C; and Dispatch Support service determined in accordance with clause 3.11.8B.*

This can be summarised as:

$$\text{Total cost}_{LF} = \text{Capacity cost}_{LF} + \text{Availability cost}_{LF}$$

where the capacity cost is calculated as the Reserve Capacity Price, multiplied by the load following requirement determined to be needed in that year.

$$\text{Capacity cost}_{LF} = \text{Reserve Capacity Price} \times \text{LF requirement}$$

The Reserve Capacity Price is determined via the Reserve Capacity Auction, or if no auction is run it is 85% of the Maximum Reserve Capacity Price reduced by an excess capacity adjustment.

Availability cost

The availability cost of providing load following is outlined in clause 9.9.2 of the WEM Rules:

9.9.2. The following terms related to Ancillary Service availability costs:

(a) the total availability cost for Trading Month m :

$$\begin{aligned}
 \text{Availability_Cost}(m) = & \\
 & 0.5 \times (\text{Margin_Peak}(m) \times \text{Sum}(d \in D, t \in \text{Peak}, \text{MCAP}(d, t) \\
 & \times (\text{Capacity_R_Peak}(m) - \text{Sum}(i \in I, \text{ASP_SRQ}(i, t)))))) \\
 & + 0.5 \times (\text{Margin_Off-Peak}(m) \times \text{Sum}(d \in D, t \in \text{Off-Peak}, \text{MCAP}(d, t) \\
 & \times (\text{Capacity_R_Off-Peak}(m) - \text{Sum}(i \in I, \text{ASP_SRQ}(i, t)))))) \\
 & + \text{Sum}(i \in I, \text{ASP_SRPayment}(i, m)) \\
 & + \text{Sum}(i \in I, \text{ASP_LFPayment}(i, m))
 \end{aligned}$$

(b) the Spinning Reserve Cost Share for Market Participant p , which is a Market Generator, for Trading Month m :

$$\begin{aligned}
 \text{Reserve_Cost_Share}(p, m) = & \\
 & 0.5 \times (\text{Margin_Peak}(m) \times \text{Sum}(d \in D, t \in \text{Peak}, \text{MCAP}(d, t) \\
 & \times \text{Reserve_Share}(p, t) \\
 & \times (\text{Capacity_R_Peak}(m) - \text{Sum}(i \in I, \text{ASP_SRQ}(i, t)) - 0.5 \text{LFR}(m)))) \\
 & + 0.5 \times (\text{Margin_Off-Peak}(m) \times \text{Sum}(d \in D, t \in \text{Off-Peak}, \text{MCAP}(d, t) \\
 & \times \text{Reserve_Share}(p, t) \\
 & \times (\text{Capacity_R_Off-Peak}(m) - \text{Sum}(i \in I, \text{ASP_SRQ}(i, t)) \\
 & - 0.5 \times \text{LFR}(m)))) \\
 & + \text{Sum}(t \in \text{Peak and Off_Peak}, \text{Reserve_Share}(p, t) \\
 & \times \text{Sum}(i \in I, \text{ASP_SRPayment}(i, m) / \text{TITM}))
 \end{aligned}$$

(c) the total Spinning Reserve Availability Cost for Trading Month m :

$$\text{Availability_Cost_R}(m) = \text{Sum}(p \in P, \text{Reserve_Cost_Share}(p, m))$$

(d) the total Load Following Availability Cost for Trading Month m :

$$\text{Availability_Cost_LF}(m) = \text{Availability_Cost}(m) - \text{Availability_Cost_R}(m)$$

Where

$\text{ASP_SRQ}(i, t)$ is the quantity of Spinning Reserve provided by Ancillary Service Provider i in Trading Interval t (this being one of the quantities referred to in clause 9.9.3);

$\text{ASP_SRPayment}(i, m)$ is defined in clause 9.9.3;

$\text{ASP_LFPayment}(i, m)$ is defined in clause 9.9.3;

TITM is the number of Trading Intervals in the Trading Month (excluding any Trading Intervals prior to Energy Market Commencement); Reserve_Share(p,t) is the share of the Spinning Reserve service payment costs allocated to Market Participant p in Trading Interval t, where this is to be determined by the IMO using the methodology described in clause 3.14.2;

Margin_Peak(m) is the reserve availability payment margin applying for Peak Trading Intervals for Trading Month m as specified by the IMO under clause 3.22.1(c);

Margin_Off-Peak(m) is the reserve availability payment margin applying for Off-Peak Trading Intervals for Trading Month m as specified by the IMO under clause 3.22.1(d);

Capacity_R_Peak(m) is the capacity necessary to cover the Ancillary Services Requirement for Spinning Reserve for Peak Trading Intervals for Trading Month m as specified by the IMO under clause 3.22.1(e);

Capacity_R_Off-Peak(m) is the capacity necessary to cover the Ancillary Services Requirement for Spinning Reserve for Off-Peak Trading Intervals for Trading Month m as specified by the IMO under clause 3.22.1(f); LFR(m) is the capacity necessary to cover the Ancillary Services Requirement for Load Following for Trading Month m as specified by the IMO under clause 3.22.1(fA);

MCAP(d,t) has the meaning given in clause 9.8.1 and = 0 if $MCAP(d,t) < 0$; Peak denotes the set of Trading Intervals occurring during Peak Trading Intervals, where "t" refers to a Trading Interval during a Trading Day; Off-Peak denotes the set of Trading Intervals occurring during Off-Peak Trading Intervals, where "t" refers to a Trading Interval during a Trading Day; and

D denotes the set of Trading Days within Trading Month m, where "d" is used to refer to a member of that set.

This can be summarised in the following way:

The Availability cost of load following is calculated as the total availability cost, minus the availability cost for providing spinning reserve.

$$\text{Availability cost}_{LF} = \text{Total Availability cost} - \text{Availability cost}_{SR}$$

The Total Availability Cost is given by:

$$\begin{aligned} \text{Total Availability Cost} = & 0.5 \times \left[M_p \times \sum_{t=p} \text{MCAP} \times (\text{SR Requirement}_p - \text{SR provided}_{\text{contracts}}) \right] \\ & + 0.5 \times \left[M_{op} \times \sum_{t=op} \text{MCAP} \times (\text{SR Requirement}_{op} - \text{SR provided}_{\text{contracts}}) \right] + \text{Contracts}_{SR} \\ & + \text{Contracts}_{LF} \end{aligned}$$

Where:

- t = Time (applying in each time period)
- p = Applying to peak periods
- op = Applying to off-peak periods
- $M_{p(op)}$ = Reserve availability payment margin applying for peak (off-peak) trading intervals. Off-peak is considered to be 10pm to 8am. This reflects the margin applied to the MCAP which is paid to Verve for being available to provide ancillary service during peak (off-peak) trading intervals.
- MCAP = Marginal Cost Administrative Price, \$/MWh calculated two business days after the relevant trading day (defined in each time period t)
- SR Requirement_{t(p,op)} = Capacity necessary for spinning reserve in peak (off-peak) intervals
- SR provided_{contracts} = Quantity of spinning reserve provided by all contracted ancillary service providers in the relevant interval. Does not include spinning reserve provided by Verve plant.
- Contracts_{SR} = Sum of all Ancillary service contracts for spinning reserve (payments under those contracts)
- Contracts_{LF} = Sum of all Ancillary service contracts for load following (payments under those contracts)

In the limiting case where there are no contracts (all spinning reserve and load following service is provided by Verve):

$$\begin{aligned} \text{Total Availability Cost} = & 0.5 \times \left[M_p \times \sum_{t=p} \text{MCAP} \times (\text{SR Requirement}_p) \right] \\ & + 0.5 \times \left[M_{op} \times \sum_{t=op} \text{MCAP} \times (\text{SR Requirement}_{op}) \right] \end{aligned}$$

Note that this equation does not refer to the load following requirement, which is not logical, particularly in the case where the load following requirement exceeds the spinning reserve (despite the additional plant required for load following, the total availability cost would not change). This is clearly not an ideal representation of the costs of providing load following and spinning reserve services. Revised equations are

proposed below (section 14.3).

Availability cost_{SR} is given by:

$$\begin{aligned}
 & 0.5 \times \left[M_p \times \sum_{t=p} \text{MCAP} \times (\text{SR Requirement}_p - \text{SR provided}_{\text{contracts}} - 0.5 \times \text{LF Requirement}) \right] \\
 & + 0.5 \times \left[M_{op} \times \sum_{t=op} \text{MCAP} \right. \\
 & \quad \left. \times (\text{SR Requirement}_{op} - \text{SR provided}_{\text{contracts}} - 0.5 \times \text{LF Requirement}) \right] \\
 & + \text{Contracts}_{SR}
 \end{aligned}$$

By subtraction, the Availability cost_{LF} is therefore given by:

$$\begin{aligned}
 \text{Availability cost}_{LF} &= 0.5 \times \left[M_p \times \sum_{t=p} \text{MCAP} \times (0.5 \times \text{LF Requirement}) \right] + \\
 & 0.5 \times \left[M_{op} \times \sum_{t=op} \text{MCAP} \times (0.5 \times \text{LF Requirement}) \right] + \text{Contracts}_{LF}
 \end{aligned}$$

This does not include a term accounting for load following provided by contracted ancillary service providers (other than Verve), and therefore would be double counting this component if load following were being provided by contract. Since this has not yet occurred, this has not affected past calculations of costs. In future however, with the load following service becoming much more substantial and possibly provided by contract, it is important that this is addressed. Revised equations are proposed below (section 14.3).

Marginal cost of ancillary services

Another problematic feature of these equations is that they assume that the marginal cost of load following is identical to the marginal cost of spinning reserve, because the same M_p and M_{op} (Margin_Peak and Margin_Off-peak) is applied identically to both services. ROAM's dispatch modelling has indicated that this is a poor approximation (outlined in section 14.9), and the costs of these services should be calibrated separately.

These equations assume that the marginal cost of load following is identical to the marginal cost of spinning reserve, because the same calibration factors are applied to both services. ROAM's dispatch modelling has indicated that this is a poor approximation (outlined in section 14.9).

ROAM recommends that separate margins are defined and calibrated for each service (load following and spinning reserve).

Allocation of cost savings

Plant providing load following service simultaneously contributes capacity to the spinning reserve service. This means that there are cost "savings" from providing both the load following and spinning reserve service simultaneously, compared with if each was provided to the full extent required in isolation. This cost "saving" must be divided somehow between market participants.

In the existing methodology, the cost of providing load following plant (availability cost) is split equally between participants liable for the load following service, and participants liable for the spinning reserve service. This assumes that the cost per megawatt of providing load following is identical to the cost per megawatt of providing spinning reserve (which is not likely to be a good approximation). This methodology can also lead to the situation where those parties liable for spinning reserve may be liable for higher costs than if they paid for spinning reserve alone (if load following is much more expensive to provide than spinning reserve).

These equations assume that the cost of load following should be split equally between participants liable for the costs of the load following service, and participants liable for the costs of the spinning reserve service. This is not an equitable distribution of costs, and can lead to unfair outcomes.

ROAM recommends that the sharing of "savings" from the dual role of load following plant in providing spinning reserve are distributed more equitably.

14.3) REVISED COST CALCULATION

If the calculation of the Availability costs were to be revised, the equations proposed below could be used. These address the immediate inaccuracies in the existing equations.

However, ROAM ultimately recommends that a competitive market for ancillary services is introduced in the SWIS, allowing the most efficient provision of ancillary services required. This market could then determine the appropriate cost for ancillary services through a bidding mechanism, similar to that applied in the NEM. A co-optimised energy and reserve market is recommended for further consideration.

14.3.1) Total Availability Cost

As before, the Total Availability payment is the sum of payments for load following and spinning reserve. Splitting these into peak and off-peak components yields the equation below.

$$\begin{aligned}
 \text{Total Availability payment} &= \text{Availability payment } VLF_p \\
 &+ \text{Availability payment } VLF_{op} + \text{Availability payment } VSR_p \\
 &+ \text{Availability payment } VSR_{op} + \text{Contracts}_{LF} + \text{Contracts}_{SR}
 \end{aligned}$$

where:

- Availability payment $VLF_{p(op)}$ = Payment to the Electricity Generation Corporation (Verve Energy) for load following in peak (off-peak) periods by parties liable for costs of load following
- Availability payment $VSR_{p(op)}$ = Payment to the Electricity Generation Corporation (Verve Energy) for spinning reserve in peak (off-peak) periods by parties liable for costs of spinning reserve
- Contracts_{LF} = Total payments under Ancillary Service Contracts for Load Following service (payments under clause 3.11.8)
- Contracts_{SR} = Total payments under Ancillary Service Contracts for Spinning Reserve service (payments under clause 3.11.8)

The appropriate equations to calculate each of these components are outlined below, for the case where the spinning reserve requirement exceeds the load following requirement, or vice versa.

Note that it is possible for the spinning reserve requirement to exceed the load following requirement in peak periods, but be lower in off-peak periods⁴⁴. In this case, the appropriate calculation should be used for peak or off peak periods as required (the appropriate peak and off-peak calculations can be combined in the Total Availability Cost equation above).

14.3.2) If SR Requirement > LF Requirement

If the spinning reserve requirement exceeds the load following requirement in the relevant period (peak or off-peak), the following equations should be applied.

The availability payment for load following in peak (or off-peak) periods is given by:

⁴⁴ Currently in the SWIS spinning reserve (70% of largest loaded unit) dominates in all intervals. It is expected that as wind farm capacity increases the load following requirement will become dominant during off-peak periods. Eventually as wind farm capacities increase further the load following requirement may be dominant over the both peak and off-peak periods.

$$\text{Availability payment VLF}_{p(op)} = (\text{MLF}_{p(op)} - \gamma_{p(op)} \times \beta_{p(op)} \times \text{MSR}_{p(op)}) \\ \times \sum_{t=p(op)} \text{MCAP} \times (\text{LF Requirement}_{p(op)} - \text{LF provided contracts}_{p(op)})$$

The availability payment of spinning reserve in peak (or off-peak) periods is given by:

$$\text{Availability payment VSR}_{p(op)} \\ = \text{MSR}_{p(op)} \\ \times \sum_{t=p(op)} \text{MCAP} \\ \times [\text{SR Requirement}_{p(op)} - \text{SR provided contracts}_{p(op)} - \gamma_{p(op)} \times (1 - \beta_{p(op)}) \\ \times (\text{LF Requirement}_{p(op)} - \text{LF provided contracts}_{p(op)})]$$

Where:

- $\text{MLF}_{p(op)}$ = Margin for Load Following in peak (off-peak) periods (%)
 $\text{MSR}_{p(op)}$ = Margin for Spinning Reserve in peak (off-peak) periods (%).
 $\beta_{p(op)}$ = Allocation factor for cost savings from sharing of load following plant for spinning reserve in peak (off-peak) periods (%).
 $\gamma_{p(op)}$ = Calibration factor for cost savings from sharing of load following plant for spinning reserve in peak (off-peak) periods (%)

Definition of $\text{MLF}_{p(op)}$ and $\text{MSR}_{p(op)}$

These are determined via the calibration process described in Section 14.3.4). They can be broadly interpreted as scaling factors such that $\text{MSR}_{p(op)}$ multiplied by average MCAP gives the average cost in \$/MWh of providing the Spinning Reserve service. Similarly, broadly speaking, $\text{MLF}_{p(op)}$ multiplied by average MCAP gives the average cost in \$/MWh of providing the Load Following service.

Definition of $\beta_{p(op)}$

$\beta_{p(op)}$ defines the percentage of the "savings" that go to participants liable for the costs of load following (in peak (off-peak) periods). $(1 - \beta_{p(op)})$ therefore defines the percentage of the "savings" that go to participants liable for the costs of spinning reserve. If $\beta_{p(op)} = 0$ the full saving goes to participants liable for the costs of spinning reserve, and participants liable for the costs of load following pay the full proportion of their costs. If $\beta_{p(op)} = 1$, the full saving goes to participants liable for the costs of load following, and participants liable for the costs of spinning reserve pay the full proportion of their costs. $\beta_{p(op)}$ is defined through a calibration process at the same time that $\text{MLF}_{p(op)}$ and $\text{MSR}_{p(op)}$ are calibrated (similar to the earlier M_p and M_{op}). The calibration process is described below (see section 14.3.4).

Definition of $\gamma_{p(op)}$

$\gamma_{p(op)}$ is a calibration factor that allows for minor adjustment of the magnitude of the "saving" that is available for distributing between participants. It is also calibrated at the same time as $MLF_{p(op)}$ and $MSR_{p(op)}$ (as described in section 14.3.4).

Corrections in these equations

These equations correct the following flaws in the existing equations in the WEM Rules:

1. They introduce the previously ignored term of the load following provided by contracted generation (LF provided_{contracts})
2. They use separate margins for the calibration of costs of load following and spinning reserve ($MLF_{p(op)}$ and $MSR_{p(op)}$), allowing for these services to have different marginal costs
3. They have a more equitable division of the "saving" provided by the shared utilisation of load following plant to simultaneously provide spinning reserve. The magnitude of the total saving is calibrated by the factor $\gamma_{p(op)}$, and the allocation of the saving between participants is determined by the factor $\beta_{p(op)}$.

Magnitude of the total saving

The magnitude of the total saving from the dual use of load following plant for spinning reserve is assumed to scale linearly with MCAP, $MSR_{p(op)}$ and the Load Following requirement. This is because:

- If the MCAP increases, the saving increases proportionally (since the costs of providing each service alone are assumed to increase in proportion to MCAP, as does the cost of providing both services together. This means that the difference between these values also scales by the same factor).
- If the load following requirement increases by 1 MW, 1MW less of spinning reserve is required. This produces a saving that is proportional to $MSR_{p(op)}$, since $MSR_{p(op)}$ gives a measure of the marginal cost of spinning reserve.

This assumption of linear scaling in these factors is likely to only be valid over a relatively small range, which makes regular re-calibration of all of these factors essential (as was required in the existing equations for M_p and M_{op}).

14.3.3) If LF Requirement > SR Requirement

If the load following requirement exceeds the spinning reserve requirement in the period of relevance (peak or off-peak), then the following equations should be applied.

The availability payment for load following in peak (or off-peak) periods is given by:

$$\begin{aligned}
 \text{Availability payment VLF}_{p(op)} &= \text{MLF}_{p(op)} \\
 &\times \sum_{t=p(op)} \text{MCAP} \\
 &\times \left(\text{LF Requirement}_{p(op)} - \text{LF provided contracts}_{p(op)} - \beta_{p(op)} \right) \\
 &\times \frac{\text{MSR}_{p(op)}}{\text{MLF}_{p(op)}} \times \text{SR Requirement}_{p(op)}
 \end{aligned}$$

The availability payment of spinning reserve in peak (or off-peak) periods is given by:

$$\text{Availability payment VSR}_{p(op)} = \text{MSR}_{p(op)} \times \beta_{p(op)} \times \sum_{t=p(op)} \text{MCAP} \times \text{SR Requirement}_{p(op)}$$

No contracts for spinning reserve

Since the load following requirement is larger than the spinning reserve requirement in this case, it is assumed that there are no contracts for spinning reserve, since the entire spinning reserve requirement is met by load following plant. This means that $\text{Contracts}_{\text{SR}} = 0$ and $\text{SR provided}_{\text{contracts}} = 0$.

Lack of appearance of $\gamma_{p(op)}$

$\gamma_{p(op)}$ does not appear in these equations. This is because there is no need for minor calibration of the total "saving" when the load following requirement exceeds the spinning reserve requirement. The total saving is simply equal to the total cost of providing the spinning reserve service, in the absence of load following. This is discussed further in section 14.3.4).

Corrections in these equations

These equations correct the following flaws in the existing equations in the WEM Rules:

1. They allow for the situation where the load following requirement exceeds the spinning reserve requirement (not allowed for in the existing Rules)
2. They introduce the previously ignored term of the load following provided by contracted generation ($\text{LF provided}_{\text{contracts}}$)
3. They use separate margins for the calibration of costs of load following and spinning reserve ($\text{MLF}_{p(op)}$ and $\text{MSR}_{p(op)}$), allowing for these services to have different marginal costs
4. They have a more equitable division of the "saving" provided by the shared utilisation of load following plant to simultaneously provide spinning reserve. The allocation of the saving between participants is determined by the factor β .

Magnitude of the total saving

The magnitude of the total saving from the dual use of load following plant for spinning reserve is assumed to scale linearly with MCAP, $MSR_{p(op)}$ and the Spinning Reserve requirement (as opposed to the Load Following requirement used previously). This is because:

- If the MCAP increases, the saving increases proportionally (since the costs of providing each service alone are assumed to increase in proportion to MCAP, as well as the cost of providing both services together)
- If the spinning reserve requirement increases by 1 MW, the total costs do not increase (because the entire spinning reserve service is provided by load following plant). However, the cost of providing that spinning reserve that would have eventuated if there were no load following does increase, in proportion to the additional capacity of spinning reserve is required. This means that the saving has increased, since a larger spinning reserve cost is now being avoided. The saving will increase in proportion to the spinning reserve requirement, and in proportion to $MSR_{p(op)}$, since $MSR_{p(op)}$ gives a measure of the marginal cost of spinning reserve.

This assumption of linear scaling in these factors is likely to only be valid over a relatively small range, which makes regular re-calibration of all of these factors essential (as was required in the existing equations for M_p and M_{op}).

14.3.4) Calibration of $MSR_{p(op)}$, $MLF_{p(op)}$, $\beta_{p(op)}$ and $\gamma_{p(op)}$

The margins for spinning reserve and load following, and the factors β and γ should be calibrated in the following way on a regular basis. This methodology is not defined in the WEM Rules, but is consistent with the equations outlined above, and it fulfils the broad requirements of clause 3.13.3A.

If SR Requirement > LF Requirement

If the spinning reserve requirement is larger than the load following requirement the following process should be used to calibrate the necessary parameters:

Perform the following dispatch simulations of the SWIS:

1. **No LF or SR** - Simulate the system dispatch with no spinning reserve or load following provided by Verve Energy (all ancillary services provided by contract should be included in the simulation)
2. **LF only** - Simulate the system dispatch with only the load following service fully provided (no spinning reserve service provided by Verve Energy, although spinning reserve provided by contracts should be included)
3. **SR only** - Simulate the system dispatch with only the spinning reserve service fully provided (no load following service provided by Verve Energy, although load following provided by contracts should be included)
4. **SR and LF** - Simulate the system dispatch with both the spinning reserve and load following services fully provided (by Verve and contracts). The load following will reduce the additional spinning reserve required, reducing costs.

Calculate availability costs according to the following equations:

$$ACVLF_{p(op)} = \sum_{t=p(op)} (\text{GenCost}_{LF} - \text{GenCost}_{NAS} + \text{GenVol}_{NAS} \times \text{MCAP}_{NAS} - \text{GenVol}_{LF} \times \text{MCAP}_{LF})$$

$$ACVSR_{p(op)} = \sum_{t=p(op)} (\text{GenCost}_{SR} - \text{GenCost}_{NAS} + \text{GenVol}_{NAS} \times \text{MCAP}_{NAS} - \text{GenVol}_{SR} \times \text{MCAP}_{SR})$$

$$ACVTOT_{p(op)} = \sum_{t=p(op)} (\text{GenCost}_{TOT} - \text{GenCost}_{NAS} + \text{GenVol}_{NAS} \times \text{MCAP}_{NAS} - \text{GenVol}_{TOT} \times \text{MCAP}_{TOT})$$

where:

$ACVLF_{p(op)}$ = Availability cost to Verve of providing load following service in peak (off-peak) periods, when Verve is not providing any spinning reserve service

$ACVSR_{p(op)}$ = Availability cost to Verve of providing spinning reserve service in peak (off-peak) periods, when Verve is not providing any load following service

$ACVTOT_{p(op)}$ = Availability cost to Verve of providing both the load following and spinning reserve services simultaneously in peak (off-peak) periods

GenCost_{NAS} = Verve's total generation costs in the scenario where Verve does not provide any load following or spinning reserve

GenCost_{LF} = Verve's total generation costs in the scenario where Verve provides only load following (no spinning reserve)

GenCost_{SR} = Verve's total generation costs in the scenario where Verve provides only spinning reserve (no load following)

GenCost_{TOT} = Verve's total generation costs in the scenario where Verve provides both load following or spinning reserve

GenVol_{NAS} = Verve's total generation in scenario where Verve does not provide any load following or spinning reserve

GenVol_{LF} = Verve's total generation in scenario where Verve provides load following but not spinning reserve

GenVol_{SR} = Verve's total generation in scenario where Verve provides spinning reserve but not load following

GenVol_{TOT} = Verve's total generation in scenario where Verve provides both load following and spinning reserve

MCAP_{TOT} = System marginal price in scenario where both load following and spinning reserve are fully provided

MCAP_{LF} = System marginal price in scenario where Verve provides load following but not spinning reserve

MCAP_{SR} = System marginal price in scenario where Verve provides spinning reserve but

not load following

Calibration of the Margins

The availability cost of load following to Verve is assumed to scale linearly with the MCAP and the load following requirement, with the constant of proportionality ($MLF_{p(op)}$) to be determined. Therefore, if only load following services were being provided by Verve:

$$ACVLF_{p(op)} = MLF_{p(op)} \times \sum_{t=p(op)} MCAP_{LF} \times (LF \text{ Requirement}_{p(op)} - LF \text{ provided contracts}_{p(op)})$$

The Margin for load following for peak and off-peak periods can therefore be calculated as:

$$MLF_{p(op)} = \frac{ACVLF_{p(op)}}{\sum_{t=p(op)} MCAP_{LF} \times (LF \text{ Requirement}_{p(op)} - LF \text{ provided contracts}_{p(op)})}$$

Similarly for spinning reserve, the availability cost of spinning reserve to Verve is assumed to scale linearly with the MCAP and the spinning reserve requirement, with the constant of proportionality ($MSR_{p(op)}$) to be determined. Therefore, if only spinning reserve services were being provided by Verve:

$$ACVSR_{p(op)} = MSR_{p(op)} \times \sum_{t=p(op)} MCAP_{SR} \times (SR \text{ Requirement}_{p(op)} - SR \text{ provided contracts}_{p(op)})$$

The Margin for spinning reserve for peak and off-peak periods can therefore be calculated as:

$$MSR_{p(op)} = \frac{ACVSR_{p(op)}}{\sum_{t=p(op)} MCAP_{SR} \times (SR \text{ Requirement}_{p(op)} - SR \text{ provided contracts}_{p(op)})}$$

Calibration of $\gamma_{p(op)}$

The total "saving" obtained in the dispatch modelling through dual use of load following plant to provide spinning reserve can be simply calculated as:

$$\text{Saving}_{p(op)} = (ACVLF_{p(op)} + ACVSR_{p(op)}) - ACVTOT_{p(op)}$$

As discussed earlier, over a small range this total saving is assumed to be directly proportional to MCAP, MSR and the Load Following requirement, and is calibrated by $\gamma_{p(op)}$. In the simplest picture, by operating one additional megawatt of load following, the operation of one megawatt

of spinning reserve plant can be avoided. Using the equation for the cost of spinning reserve from the previous section the total saving is therefore given by:

$$\text{Saving}_{p(op)} = \gamma_{p(op)} \times \text{MSR}_{p(op)} \times \sum_{t=p(op)} \text{MCAP}_{\text{TOT}} \times (\text{LF Requirement}_{p(op)} - \text{LF provided contracts}_{p(op)})$$

The factor $\gamma_{p(op)}$ is a calibration factor that captures deviations from this simple model. For example, it is likely that the spinning reserve plant removed from spinning reserve service will be the most expensive plant, and therefore more expensive than the average cost per megawatt of spinning reserve. Therefore we define the additional calibration factor $\gamma_{p(op)}$, which is calibrated via dispatch simulations in a similar manner to the other parameters under analysis here. Following from the equation above, $\gamma_{p(op)}$ is calibrated as follows:

$$\gamma_{p(op)} = \frac{(\text{ACVLF}_{p(op)} + \text{ACVSR}_{p(op)}) - \text{ACVTOT}_{p(op)}}{\text{MSR}_{p(op)} \times \sum_{t=p(op)} \text{MCAP}_{\text{TOT}} \times (\text{LF Requirement}_{p(op)} - \text{LF provided contracts}_{p(op)})}$$

Calibration of $\beta_{p(op)}$

The factor $\beta_{p(op)}$ for allocating the amount of the "saving" that is allocated to participants liable for load following can be calibrated according to:

$$\beta_{p(op)} = \frac{\text{ACVLF}_{p(op)}}{\text{ACVLF}_{p(op)} + \text{ACVSR}_{p(op)}}$$

This allocates the saving based upon the relative magnitude of the total costs of load following and spinning reserve. If providing load following has a much higher total cost than providing spinning reserve (either due to a larger load following requirement, or a higher per megawatt cost) then a larger proportion of the saving will be allocated to parties liable for the load following service. Similarly if the total cost of providing the spinning reserve service is much larger than the total cost of providing the load following service then a larger proportion of the saving will be allocated to the participants liable for the costs of the spinning reserve service. This allocation is considered more equitable than a 50% allocation, since it is proportionate to the relative costs of the two services.

Importantly, via this methodology neither group of participants (those liable for spinning reserve, or those liable for load following) can be required to pay for the other service (as can occur in the existing methodology). They simply share the saving that comes from dual use of plant to provide both services simultaneously. This is an important correction from the previous methodology.

If LF Requirement > SR Requirement

If the load following requirement is larger than the spinning reserve requirement the following process should be used to calibrate the Margins for spinning reserve and load following for peak and off-peak periods.

1. **No SR or LF** - Simulate the system dispatch with no spinning reserve or load following provided by Verve Energy (all ancillary services provided by contract should be included in the simulation)
2. **SR only** - Simulate the system dispatch with the spinning reserve service fully provided (no load following service provided by Verve Energy, although load following provided by contracts should be included)
3. **LF only / SR and LF** - Simulate the system dispatch with both the spinning reserve and load following services fully provided (by Verve and contracts). Note that since the load following requirement exceeds the spinning reserve requirement this means that no additional spinning reserve requirement is required in excess of the plant providing the load following service.

Calculate availability costs according to the following equations:

$$ACVLF_{p(op)} = \sum_{t=p(op)} (\text{GenCost}_{LF} - \text{GenCost}_{NAS} + \text{GenVol}_{NAS} \times MCAP_{NAS} - \text{GenVol}_{LF} \times MCAP_{LF})$$

$$ACVSR_{p(op)} = \sum_{t=p(op)} (\text{GenCost}_{SR} - \text{GenCost}_{NAS} + \text{GenVol}_{NAS} \times MCAP_{NAS} - \text{GenVol}_{SR} \times MCAP_{SR})$$

The required parameters can then be calculated via:

$$MLF_{p(op)} = \frac{ACVLF_{p(op)}}{\sum_{t=p(op)} MCAP_{LF} \times (\text{LF Requirement}_{p(op)} - \text{LF provided contracts}_{p(op)})}$$

$$MSR_{p(op)} = \frac{ACVSR_{p(op)}}{\sum_{t=p(op)} MCAP_{SR} \times (\text{SR Requirement}_{p(op)})}$$

$$\beta_{p(op)} = \frac{ACVLF_{p(op)}}{ACVLF_{p(op)} + ACVSR_{p(op)}}$$

14.4) REVISED COST CALCULATION IN WEM RULES TERMINOLOGY

The proposed revised cost calculation could be written as the revised clauses in the following way⁴⁵. These address the immediate inaccuracies in the existing equations. However, ROAM ultimately recommends that a competitive market for ancillary services is introduced in the SWIS, allowing the most efficient provision of ancillary services required.

14.4.1) Proposed revised Clause 9.9.2

9.9.2 (PROPOSED REVISION). The following terms related to Ancillary Service availability costs:

(a) the total availability cost for Trading Month m :

$$\begin{aligned}
 \text{Availability_Cost}(m) &= \text{Availability_Cost_R}(m) + \text{Availability_Cost_LF}(m) \\
 &0.5 \times (\text{Margin_Peak}(m) \times \text{Sum}(d \in D, t \in \text{Peak}, \text{MCAP}(d, t) \\
 &\times (\text{Capacity_R_Peak}(m) - \text{Sum}(i \in I, \text{ASP_SRQ}(i, t)))) \\
 &+ 0.5 \times (\text{Margin_Off-Peak}(m) \times \text{Sum}(d \in D, t \in \text{Off-Peak}, \text{MCAP}(d, t) \\
 &\times (\text{Capacity_R_Off-Peak}(m) - \text{Sum}(i \in I, \text{ASP_SRQ}(i, t)))) \\
 &+ \text{Sum}(i \in I, \text{ASP_SRPayment}(i, m)) \\
 &+ \text{Sum}(i \in I, \text{ASP_LFPayment}(i, m))
 \end{aligned}$$

(b) If the Spinning Reserve requirement is greater than the Load Following requirement, the Spinning Reserve Cost Share for Market Participant p , which is a Market Generator, for Trading Month m :

$$\begin{aligned}
 \text{Reserve_Cost_Share}(p, m) &= \\
 &0.5 \times (\text{Margin_Peak_SR}(m) \times \text{Sum}(d \in D, t \in \text{Peak}, \text{MCAP}(d, t) \\
 &\times \text{Reserve_Share}(p, t) \\
 &\times (\text{Capacity_R_Peak}(m) - \text{Sum}(i \in I, \text{ASP_SRQ}(i, t)) \\
 &- \text{Savings_Cal_Peak}(m) \times (1 - \text{Savings_Alloc_Peak}(m))) 0.5 \\
 &\times (\text{LFR}(m) - \text{Sum}(i \in I, \text{ASP_LFQ}(i, t)))) \\
 &+ 0.5 \times (\text{Margin_Off-Peak_SR}(m) \times \text{Sum}(d \in D, t \in \text{Off-Peak}, \text{MCAP}(d, t) \\
 &\times \text{Reserve_Share}(p, t) \\
 &\times (\text{Capacity_R_Off-Peak}(m) - \text{Sum}(i \in I, \text{ASP_SRQ}(i, t)) \\
 &- \text{Savings_Cal_Off-Peak}(m) \times (1 - \text{Savings_Alloc_Off-Peak}(m))) 0.5 \\
 &\times (\text{LFR}(m) - \text{Sum}(i \in I, \text{ASP_LFQ}(i, t)))) \\
 &+ \text{Sum}(t \in \text{Peak and Off_Peak}, \text{Reserve_Share}(p, t) \\
 &\times \text{Sum}(i \in I, \text{ASP_SRPayment}(i, m) / \text{TITM}))
 \end{aligned}$$

⁴⁵ Text in red indicates additions to the text in the existing WEM Rules.

If the Load Following requirement is greater than the Spinning Reserve requirement, the Spinning Reserve Cost Share for Market Participant p , which is a Market Generator, for Trading Month m :

$$\begin{aligned}
 \text{Reserve_Cost_Share}(p,m) = & \\
 & 0.5 \times (\text{Margin_Peak_SR}(m) \times \text{Savings_Alloc_Peak}(m) \\
 & \times \text{Sum}(d \in D, t \in \text{Peak}, \text{MCAP}(d,t)) \\
 & \times \text{Reserve_Share}(p,t) \\
 & \times (\text{Capacity_R_Peak}(m) - \text{Sum}(i \in I, \text{ASP_SRQ}(i,t)) - 0.5 \times \text{LFR}(m))) \\
 & + 0.5 \times (\text{Margin_Off-Peak_SR}(m) \times \text{Savings_Alloc_Off-Peak}(m) \\
 & \times \text{Sum}(d \in D, t \in \text{Off-Peak}, \text{MCAP}(d,t)) \\
 & \times \text{Reserve_Share}(p,t) \\
 & \times (\text{Capacity_R_Off-Peak}(m) - \text{Sum}(i \in I, \text{ASP_SRQ}(i,t)) - 0.5 \times \text{LFR}(m))) \\
 & + \text{Sum}(t \in \text{Peak and Off-Peak}, \text{Reserve_Share}(p,t) \\
 & \times \text{Sum}(i \in I, \text{ASP_SRPayment}(i,m) / \text{TITM}))
 \end{aligned}$$

(c) the total Spinning Reserve Availability Cost for Trading Month m :

$$\text{Availability_Cost_R}(m) = \text{Sum}(p \in P, \text{Reserve_Cost_Share}(p,m))$$

(d) *If the Spinning Reserve requirement is greater than the Load Following requirement, the total Load Following Availability Cost for Trading Month m is given by:*

$$\begin{aligned}
 \text{Availability_Cost_LF}(m) = & \text{Availability_Cost}(m) - \text{Availability_Cost_R}(m) \\
 & (\text{Margin_Peak_LF}(m) \\
 & - \text{Savings_Cal_Peak}(m) \times \text{Savings_Alloc_Peak}(m) \\
 & \times \text{Margin_Peak_SR}(m) \\
 & \times \text{Sum}(d \in D, t \in \text{Peak}, \text{MCAP}(d,t)) \\
 & \times (\text{LFR}(m) - \text{Sum}(i \in I, \text{ASP_LFQ}(i,t)))) \\
 & + (\text{Margin_Off-Peak_LF}(m) \\
 & - \text{Savings_Cal_Off-Peak}(m) \times \text{Savings_Alloc_Off-Peak}(m) \\
 & \times \text{Margin_Off-Peak_SR}(m) \\
 & \times \text{Sum}(d \in D, t \in \text{Off-Peak}, \text{MCAP}(d,t)) \\
 & \times (\text{LFR}(m) - \text{Sum}(i \in I, \text{ASP_LF}(i,t)))) \\
 & + \text{Sum}(i \in I, \text{ASP_LFPayment}(i,m))
 \end{aligned}$$

If the Load Following requirement is greater than the Spinning Reserve requirement, the total Load Following Availability Cost for Trading Month m :

$$\begin{aligned}
 \text{Availability_Cost_LF}(m) &= \text{Availability_Cost}(m) - \text{Availability_Cost_R}(m) \\
 &\times \text{Margin_Peak_LF}(m) \times \text{Sum}(d \in D, t \in \text{Peak}, \text{MCAP}(d, t)) \\
 &\times (\text{LFR}(m) - \text{Sum}(i \in I, \text{ASP_LFQ}(i, t))) \\
 &- \text{Savings_Alloc_Peak}(m) \\
 &\times \text{Margin_Peak_SR}(m) \div \text{Margin_Peak_LF}(m) \\
 &\times \text{Capacity_R_Peak}(m) \\
 &+ \text{Margin_Off-Peak_LF}(m) \times \text{Sum}(d \in D, t \in \text{Off-Peak}, \text{MCAP}(d, t)) \\
 &\times (\text{LFR}(m) - \text{Sum}(i \in I, \text{ASP_LFQ}(i, t))) \\
 &- \text{Savings_Alloc_Off-Peak}(m) \\
 &\times \text{Margin_Off-Peak_SR}(m) \div \text{Margin_Off-Peak_LF}(m) \\
 &\times \text{Capacity_R_Off-Peak}(m) \\
 &+ \text{Sum}(i \in I, \text{ASP_SRPayment}(i, m))
 \end{aligned}$$

Where

ASP_SRQ(i,t) is the quantity of Spinning Reserve provided by Ancillary Service Provider i in Trading Interval t (this being one of the quantities referred to in clause 9.9.3);

ASP_LFQ(i,t) is the quantity of Load Following provided by Ancillary Service Provider i in Trading Interval t;

ASP_SRPayment(i,m) is defined in clause 9.9.3;

ASP_LFPayment(i,m) is defined in clause 9.9.3;

TITM is the number of Trading Intervals in the Trading Month (excluding any Trading Intervals prior to Energy Market Commencement); Reserve_Share(p,t) is the share of the Spinning Reserve service payment costs allocated to Market Participant p in Trading Interval t, where this is to be determined by the IMO using the methodology described in clause 3.14.2;

Margin_Peak_SR(m) is the reserve availability payment margin applying for Spinning Reserve for Peak Trading Intervals for Trading Month m as specified by the IMO under clause 3.22.1(c);

Margin_Peak_LF(m) is the reserve availability payment margin applying for Load Following for Peak Trading Intervals for Trading Month m as specified by the IMO under clause 3.22.1(cA);

Margin_Off-Peak_SR(m) is the reserve availability payment margin applying for Spinning Reserve for Off-Peak Trading Intervals for Trading Month m as specified by the IMO under clause 3.22.1(d);

Margin_Off-Peak_LF(m) is the reserve availability payment margin applying for Load Following for Off-Peak Trading Intervals for Trading Month m as specified by the IMO under clause 3.22.1(dA);

Savings_Alloc_Peak(m) is the allocation factor for cost savings from dual use of planting providing Load Following service to simultaneously provide Spinning Reserve service, applying for peak periods for Trading Month m as specified by the IMO under clause 3.22.1(dB)

Savings_Alloc_Off-Peak(m) is the allocation factor for cost savings from dual use of planting providing Load Following service to simultaneously provide Spinning Reserve service, applying for off-peak periods for Trading Month m as specified by the IMO under clause 3.22.1(dC)

Savings_Cal_Peak(m) is the calibration factor for for cost savings from dual use of planting providing Load Following service to simultaneously provide Spinning Reserve service, applying for peak periods for Trading Month m as specified by the IMO under clause 3.22.1(dD)

Savings_Cal_Off-Peak(m) is the calibration factor for for cost savings from dual use of planting providing Load Following service to simultaneously provide Spinning Reserve service, applying for off-peak periods for Trading Month m as specified by the IMO under clause 3.22.1(dE)

Capacity_R_Peak(m) is the capacity necessary to cover the Ancillary Services Requirement for Spinning Reserve for Peak Trading Intervals for Trading Month m as specified by the IMO under clause 3.22.1(e);

Capacity_R_Off-Peak(m) is the capacity necessary to cover the Ancillary Services Requirement for Spinning Reserve for Off-Peak Trading Intervals for Trading Month m as specified by the IMO under clause 3.22.1(f); LFR(m) is the capacity necessary to cover the Ancillary Services Requirement for Load Following for Trading Month m as specified by the IMO under clause 3.22.1(fA);

LFR(m) is the capacity necessary to cover the Ancillary Services Requirement for Load Following for Trading Month m as specified by the IMO under clause 3.22.1(fA);

MCAP(d,t) has the meaning given in clause 9.8.1 and =0 if $MCAP(d,t) < 0$; Peak denotes the set of Trading Intervals occurring during Peak Trading Intervals,

where “t” refers to a Trading Interval during a Trading Day; Off-Peak denotes the set of Trading Intervals occurring during Off-Peak Trading Intervals, where “t” refers to a Trading Interval during a Trading Day; and

D denotes the set of Trading Days within Trading Month m, where “d” is used to refer to a member of that set.

14.4.2) Proposed revised clause 3.13.3

The calibration methodology described above for the Margin_peak and Margin_Off-peak values is not detailed in the WEM Rules. However, clause 3.13.3 refers to these parameters, and would need to be revised to incorporate separate Margins for load following and spinning reserve. This clause could be re-written as follows⁴⁶:

3.13.3 (PROPOSED REVISION). The parameters Margin_Peak_LF, Margin_Off-Peak_LF, Margin_Peak_SR, ~~and~~ Margin_Off-Peak_SR, Savings_Alloc_Peak, Savings_Alloc_Off-Peak, Savings_Cal_Peak and Savings_Cal_Off-Peak to be used in the settlement calculation described in clause 9.9.2 are:

(a) where the Economic Regulation Authority has not completed its first assessment in accordance with clause 3.13.3A:

- i. 15 % for Margin_Peak_LF and Margin_Peak_SR; and
- ii. 12% for Margin_Off-Peak_LF and Margin_Off-Peak_SR; and
- iii. 50% for Savings_Alloc_Peak; and
- iv. 50% for Savings_Alloc_Off-Peak; and
- v. 100% for Savings_Cal_Peak; and
- vi. 100% for Savings_Cal_Off-Peak; and

(b) determined by the Economic Regulation Authority, where the Economic Regulation Authority has completed its first assessment in accordance with clause 3.13.3A.

14.4.3) Proposed revised clause 3.13.3A

The methodology discussed in section 14.3.4) of this report is consistent with clause 3.13.3A in the WEM Rules, which outlines the broad principles for determining the Margin values. Clause 3.13.3A simply needs to be revised to refer to the separate margins for load following and spinning reserve, and the other parameters that need to be calibrated.

3.13.3A (PROPOSED REVISION). For each Financial Year, by 31 March prior to the start of that Financial Year, the Economic Regulation Authority must determine values for the parameters Margin_Peak_LF, Margin_Peak_SR, Margin_Off-peak_LF, ~~and~~ Margin_Off-Peak_SR, Savings_Alloc_Peak, Savings_Alloc_Off-Peak, Savings_Cal_Peak and Savings_Cal_Off-Peak taking

⁴⁶ Text in red indicates additions to the text in the existing WEM Rules.

into account the Wholesale Market Objectives and in accordance with the following:

- (a) by 30 November prior to the start of the Financial Year, the IMO must submit a proposal for the Financial Year to the Economic Regulation Authority:
- i. for the reserve availability payment margins applying for Peak Trading Intervals, *Margin_Peak_LF and Margin_Peak_SR, and the parameters Savings_Alloc_Peak and Savings_Cal_Peak*, the IMO must take account of:
 1. the margin the Electricity Generation Corporation could reasonably have been expected to earn on energy sales forgone due to the supply of Spinning Reserve *and Load Following* during Peak Trading Intervals;
 2. the loss in efficiency of the Electricity Generation Corporation Registered Facilities that System Management has scheduled to provide Spinning Reserve *and Load Following* during Peak Trading Intervals that could reasonably be expected due to the scheduling of those reserves;
 - ii. for the reserve availability payment margins applying for Off-Peak Trading Intervals, *Margin_Off-Peak_LF and Margin_Off-Peak_SR, and the parameters Savings_Alloc_Off-Peak and Savings_Cal_Off-Peak*, the IMO must take account of:
 1. the margin the Electricity Generation Corporation could reasonably have been expected to earn on energy sales forgone due to the supply of Spinning Reserve *and Load Following* during Off-Peak Trading Intervals;
 2. the loss in efficiency of the Electricity Generation Corporation Registered Facilities that System Management has scheduled to provide Spinning Reserve *and Load Following* during Off-Peak Trading Intervals that could reasonably be expected due to the scheduling of those reserves;
- (b) the Economic Regulation Authority must undertake a public consultation process, which must include publishing an issues paper and issuing an invitation for public submission

14.4.4) Proposed revised clause 3.22.1

3.22.1 (PROPOSED REVISION). The IMO must provide the following information to the Settlement System for each

Trading Month:

- (a) Capacity_LF as described in clause 3.13.1(aA);

- (b) [Blank]
- (c) *Margin_Peak_SR as described in clause 3.13.3A;*
- (cA) *Margin_Peak_LF as described in clause 3.13.3A;*
- (d) *Margin_Off-Peak_SR as described in clause 3.13.3A;*
- (dA) *Margin_Off-Peak_LF as described in clause 3.13.3A;*
- (dB) *Savings_Alloc_Peak as described in clause 3.13.3A;*
- (dC) *Savings_Alloc_Off-Peak as described in clause 3.13.3A;*
- (dD) *Savings_Cal_Peak as described in clause 3.13.3A;*
- (dE) *Savings_Cal_Off-Peak as described in clause 3.13.3A;*
- (e) *Capacity_R_Peak, the requirement for Spinning Reserve for Peak Trading Intervals assumed in forming Margin_Peak_LF and Margin_Peak_SR;*
- (f) *Capacity_R_Off-Peak, the requirement for Spinning Reserve for Off-Peak Trading Intervals assumed in forming Margin_Off-Peak_LF and Margin_Off-Peak_SR;;*
- (fA) *LFR as described in clause 3.13.1(aA)(i)(2);*
- (g) *Cost_LRD as the sum of:*
 - i. *Cost_LR (as described in clause 3.13.3B and 3.13.3C) divided by 12 as a monthly amount; and*
 - ii. *the monthly amount for Dispatch Support service as advised in (h) the compensation due to changed outage plans to be paid to a Market Participant for that Trading Month as determined in accordance with clause 3.19.12(e).*

14.4.5) Establishment of a market for ancillary services

The establishment of an efficient market for load following and spinning reserve services would avoid determining the costs of providing these services via arbitrary equations with the need for constant revision of calibration factors.

Establishment of a market for ancillary services (specifically load following and spinning reserve) would require revision of the following clauses in the WEM Rules: 3.11.7 (planning), 3.11.7A (Electricity Generation Corporation), 3.11.8, 3.11.8E, (contracts), 3.13.1 (payment for ancillary services), 3.13.3, 3.13.3A (calibration of Margin_Peak and Margin_Off-peak), 9.9.1, 9.9.2 (settlement amount), 9.9.3, 9.9.4 (contracts).

The following clauses may also require revision, depending upon the nature of the market established: 3.11.9 (cost minimisation), 3.11.10, 3.11.11 (contract reporting), 3.11.12, 3.11.13 (planning and reporting), 3.11.14 (tender process reporting), 3.11.15 (market procedure), 3.12.1 (dispatch of ancillary services), 3.13.1A (settlement information), 3.13.2 (payments for ancillary services).

14.5) ACCURACY OF COST CALCULATIONS

It should be noted that these equations do not actually provide an accurate estimation of the costs of load following, but rather give a measure of compensation to be provided based upon a convenient estimation mechanism. The Margins for peak and off-peak periods are a calibration tool that adjusts the output of these equations to match with actual costs. The equations therefore capture something of the proportionality of the costs with the load following requirement and the MCAP, but will only be applicable over a narrow range of these variables. The re-calculation of the Margin for peak and off-peak intervals on a regular basis is essential for re-calibrating the accuracy of these equations to represent actual costs.

Significantly, the Margin is calculated through dispatch modelling exercises, and will depend upon the MCAP and the load following requirement. It is therefore not an independent variable in the above equations. This can create strange dependencies, and makes it particularly important that the Margin is recalibrated frequently, particularly at the onset of any different market conditions (significant changes in MCAP, the introduction of a carbon market, or a substantial increase in the amount of load following required).

Upon careful investigation of these equations, ROAM believes that they are not ideal for long term forecasting of costs. However, since these equations are the existing basis for payments to Verve, ROAM has used them to provide an estimate of ranges of possible costs. ROAM suggests that the costing procedure be substantially reviewed, and that the SWIS moves towards a market based mechanism for procuring and costing ancillary services (similar to that utilised in the NEM).

14.6) ANCILLARY SERVICES IN THE NEM

In the NEM, the Australian Energy Market Operator (AEMO) is responsible for ensuring the safe, secure and reliable operation of the power system. To do this, Frequency Control Ancillary Services are purchased from market participants through a competitive spot market⁴⁷. Participants wishing to offer ancillary services register for each separate category that are willing (and able) to supply (e.g., Fast Raise (6 Second Raise), Delayed Raise (5 Minute Raise), etc.) and submit a bid for the capacity which they are able to offer.

During each dispatch interval, AEMO's dispatch engine then enables a sufficient amount of capacity in each category to meet the requirements for that period. This is done in merit order of cost with the highest cost offer to be enabled setting the marginal price for that category (which all active participants will be paid for that interval). Arrangements exist for the modification of the energy target of scheduled generators to minimize the total cost (energy plus ancillary services) to the market.

Costs are allocated on a "causer pays" basis, with a "contribution factor" assigned to each participant for each 5 minute dispatch interval, and costs distributed proportionately between

⁴⁷ <http://www.aemo.com.au/electricityops/0160-0025.pdf>

both generators and customers.⁴⁸ Costs for ancillary services in the NEM were \$261,000,000 in the 2008-09 financial year.⁴⁹ An average of the weekly cost to customers (only) of ancillary services per unit demand in the NEM is shown in Figure 14.1. Total cost of ancillary services per unit energy was closer to \$0.90/MWh on average, but this may misrepresent the appropriate division of costs between generators and customers.

Figure 14.1 – Customer cost of ancillary services in the NEM⁵⁰

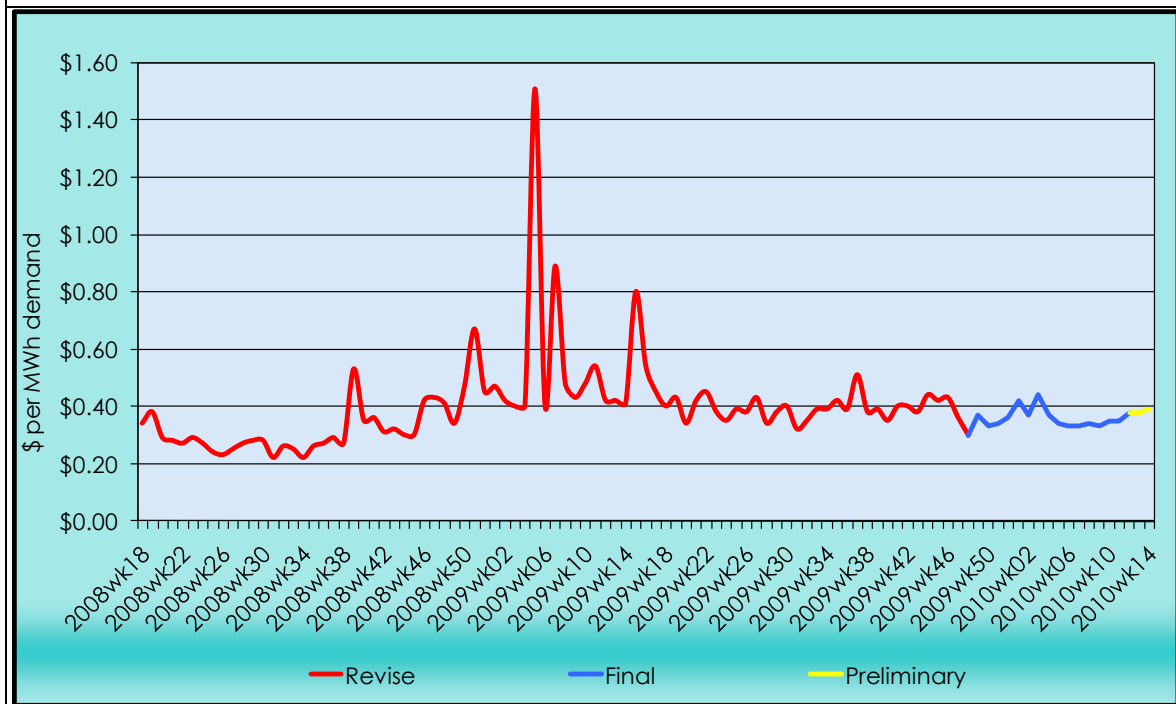

14.7) HISTORICAL COSTS OF LOAD FOLLOWING SERVICE

Costs of ancillary services as published by Western Power are listed in Table 14.1.

	Cost of load following (\$)	Amount of load following provided (MW)	Cost of load following (\$/MW)
2006-07	1,421,213	47	30,239
2007-08	1,489,716	50	29,794

⁴⁸ <http://www.aemo.com.au/electricityops/0160-0016.pdf>

⁴⁹ Based on http://www.nemweb.com.au/REPORTS/CURRENT/Ancillary_Services_Payments/

⁵⁰ Created from http://www.nemweb.com.au/REPORTS/CURRENT/Ancillary_Services_Payments/

2008-09	9,823,018 (Capacity - 6,441,298) (Availability - 3,381,721)	60	163,717
----------------	---	----	---------

14.8) PROJECTION OF FUTURE COSTS

There are two possible approaches to quantifying the future costs of providing the load following service:

1. Use the existing methodology outlined in the WEM Rules to determine what the apparent costs to market participants would be, if the Rules remain as they are.
2. Use a first principles approach to quantify the "actual" costs associated with the provision of the load following service.

ROAM has focused on the first approach for this study, since it provides more insight into possible flaws in the existing rules, and a better estimation of the costs that will actually be faced by market participants if the Rules remain as they are. First principles dispatch modelling was conducted for Scenario 2 to provide a comparison.

Upon undertaking this investigation, ROAM has determined that the existing methodology for calculating load following costs in the WEM Rules is not an accurate measure of "actual" costs of the provision of this service, particularly over the long term (as described above). This is an important insight, leading to the recommendation that this methodology is reviewed and addressed as a priority.

Since the existing methodology does not provide an accurate measure of "actual" costs, the projections of costs made on the basis of this existing methodology are similarly not an accurate measure of the actual costs of the provision of the load following service. Actual costs could instead be forecast on the basis of a dispatch modelling study⁵¹, as has been performed for Scenario 2 (see section 14.9).

14.8.1) Capacity Costs

Benchmarking

Based upon Reserve Capacity Prices published annually by the IMO (Table 14.2) and the amount of load following required in 2008-09, ROAM's calculation of the Capacity Cost of load following (utilising the equations outlined above) is consistent with the Capacity Cost published in 2008-09. Separate Capacity Costs and Availability Costs for load following were not published in earlier years.

⁵¹ Report to Independent Market Operator of Western Australia, 2009 Margin_Peak and Margin_Off-Peak review, Final Report v4.0. MMA, 20 December 2009.

Year	Reserve Capacity Price (\$/MW/year)
2006	\$127,500
2006-07	\$127,500
2007-08	\$127,500
2008-09	\$97,835
2009-10	\$108,459
2010-11	\$144,235
2011-12	\$131,805

Projection of future costs

To provide a projection of future Capacity Costs, ROAM has projected forward the average Reserve Capacity Price from 2010-11 and 2011-12 (\$138,020/MW pa), on the assumption that the technologies available to provide capacity to the market are likely to remain relatively unchanged over the period of this study. Projected Capacity Costs for load following on this basis are listed in Table 14.3.

Year	Load following requirement (MW)	Projected Capacity Cost - Load Following (\$pa)			
		Scenario 1	Scenario 2	Scenario 3	Scenario 4
2009-10	65	\$7,002,844	\$7,007,508	\$7,002,844	\$7,034,623
2010-11	66	\$9,577,229	\$9,598,865	\$9,577,229	\$9,654,684
2011-12	72	\$9,548,846	\$9,462,646	\$9,548,846	\$9,381,455
2012-13	133	\$18,382,881	\$13,685,095	\$13,711,319	\$13,635,408
2013-14	134	\$18,519,521	\$18,472,594	\$18,519,521	\$18,458,792
2014-15	232	\$32,015,115	\$18,490,537	\$19,079,882	\$18,574,729
2015-16	233	\$32,175,218	\$18,675,483	\$20,812,033	\$18,690,666
2016-17	234	\$32,292,535	\$20,741,643	\$20,969,376	\$18,893,555
2017-18	235	\$32,448,497	\$20,875,522	\$21,144,661	\$20,806,512
2018-19	245	\$33,802,473	\$21,009,401	\$25,241,094	\$21,012,162
2019-20	245	\$33,868,723	\$21,205,390	\$25,416,379	\$21,115,677

2020-21	256	\$35,316,552	\$21,394,477	\$25,557,160	\$22,371,659
2021-22	257	\$35,494,598	\$21,493,851	\$25,710,362	\$22,582,829
2022-23	258	\$35,593,973	\$22,800,901	\$27,267,227	\$22,682,204
2023-24	259	\$35,690,587	\$22,945,822	\$27,488,059	\$22,851,968
2024-25	260	\$35,821,706	\$23,143,190	\$27,619,178	\$22,999,649
2025-26	261	\$35,974,908	\$23,369,543	\$27,877,276	\$23,147,331
2026-27	270	\$37,308,181	\$23,577,953	\$28,204,383	\$23,325,377
2027-28	272	\$37,535,914	\$23,834,670	\$32,950,890	\$23,619,359
2028-29	273	\$37,691,876	\$29,810,935	\$33,156,540	\$27,561,210
2029-30	296	\$40,837,352	\$29,908,930	\$33,369,091	\$27,795,844
2030-31	297	\$40,965,710	\$30,125,621	\$33,563,699	\$27,949,046

14.8.2) Availability costs

Availability costs apply to both the spinning reserve and load following ancillary services, and are shared between the two (since the same plant can provide both services simultaneously). Availability costs as published by Western Power for 2008-09 are listed in the first row of Table 14.4. The later rows show a projection of these costs to later years, assuming a linear scaling with the quantity of ancillary services required. A linear scaling is implied by the equations outlined above for the calculation of costs.

Significantly, these projections assume that the existing market conditions continue relatively unchanged. Also, they assume that the existing structure of the Rules is maintained, particularly around the division of costs between spinning reserve and load following. ROAM's modelling suggests that this existing division of cost (as defined in the Rules) may be inaccurate, and should be reviewed (refer to section 14.9). These projections may therefore not be an accurate reflection of true costs, but rather provide an indication of future costs if market conditions and Rules remain similar to existing conditions and Rules.

M _p	Year	Load following requirement (MW)	Spinning Reserve requirement (peak) (MW)	Availability cost (\$ pa)		
				Total	Load Following	Spinning Reserve
15%	2008-09 (as published)	60	220	28,092,698	3,381,721	24,710,977
15%	2014-15 (projected)	232	220	29,619,920	17,220,276	12,399,643

	2020-21 (projected)	256	220	32,674,362	20,274,719	12,399,643
	2030-31 (projected)	297	220	37,900,881	25,501,238	12,399,643
30%	2014-15 (projected)	232	220	59,239,839	34,440,552	24,799,287
	2020-21 (projected)	256	220	65,348,724	40,549,437	24,799,287
	2030-31 (projected)	297	220	75,801,762	51,002,475	24,799,287

Table 14.5 – Availability costs (Scenario 2)

M _p	Year	Load following requirement (MW)	Spinning Reserve requirement (peak) (MW)	Availability cost (\$ pa)		
				Total	Load Following	Spinning Reserve
15%	2008-09 (as published)	60	220	28,092,698	3,381,721	24,710,977
15%	2014-15 (projected)	134	220	28,092,698	7,550,819	20,541,879
	2020-21 (projected)	155	220	28,092,698	8,736,676	19,356,022
	2030-31 (projected)	218	220	28,092,698	12,302,137	15,790,561
30%	2014-15 (projected)	134	220	56,185,397	15,101,638	41,083,758
	2020-21 (projected)	155	220	56,185,397	17,473,352	38,712,045
	2030-31 (projected)	218	220	56,185,397	24,604,274	31,581,123

Table 14.6 – Availability costs (Scenario 3)

M _p	Year	Load following requirement (MW)	Spinning Reserve requirement (peak) (MW)	Availability cost (\$ pa)		
				Total	Load Following	Spinning Reserve
15%	2008-09 (as published)	60	220	28,092,698	3,381,721	24,710,977

15%	2014-15 (projected)	138	220	28,092,698	7,791,485	20,301,213
	2020-21 (projected)	185	220	28,092,698	10,436,554	17,656,144
	2030-31 (projected)	243	220	31,052,647	18,653,004	12,399,643
30%	2014-15 (projected)	138	220	56,185,397	15,582,970	40,602,427
	2020-21 (projected)	185	220	56,185,397	20,873,109	35,312,288
	2030-31 (projected)	243	220	62,105,294	37,306,008	24,799,287

Table 14.7 – Availability costs (Scenario 4)						
M _p	Year	Load following requirement (MW)	Spinning Reserve requirement (peak) (MW)	Availability cost (\$ pa)		
				Total	Load Following	Spinning Reserve
15%	2008-09 (as published)	60	220	28,092,698	3,381,721	24,710,977
15%	2014-15 (projected)	135	220	28,092,698	7,585,200	20,507,498
	2020-21 (projected)	162	220	28,092,698	9,135,719	18,956,979
	2030-31 (projected)	203	220	28,092,698	11,413,308	16,679,390
30%	2014-15 (projected)	135	220	56,185,397	15,170,400	41,014,997
	2020-21 (projected)	162	220	56,185,397	18,271,438	37,913,959
	2030-31 (projected)	203	220	56,185,397	22,826,616	33,358,780

Assumptions

These projections were made on the Total Availability Cost scaling linearly with whichever ancillary service requirement was larger (load following or spinning reserve). In Scenario 1, from 2014-15 onwards the load following requirement is larger, and therefore dictates the scaling of the Total Availability Cost.

The projected Total Availability Cost was then split into load following and spinning reserve components using the published load following Availability cost from 2008-09. The existing equations defined in the WEM rules do not provide for the situation where the load following requirement exceeds the spinning reserve requirement, so ROAM has assumed that the costs of spinning reserve would be treated like the costs of load following are currently treated (as outlined in the equations above). The load following Availability Cost in 2008-09 was therefore scaled proportional to the peak spinning reserve requirement to determine the spinning reserve Availability Cost. The remaining Total Availability Cost was attributed to the Load Following Availability Cost.

These results assume that the MCAP does not change significantly. If the MCAP were to increase, the equations listed above indicate that the Total Availability Cost should increase proportionally. This may occur due to an emissions trading scheme or carbon price, or due to an increase in fuel costs. There is great uncertainty around these parameters at the moment.

It has been assumed for this analysis that peak conditions dominate; in particular that the availability cost for spinning reserve is dominated by peak trading intervals. This is likely to be the case, since the MCAP is likely to be significantly larger in peak intervals, and the spinning reserve requirement will also be larger, giving a much stronger weighting to these intervals in the sum.

M_p

The cost equations in the WEM rules use a Margin in peak and off-peak intervals to arbitrarily adjust the availability costs to the "correct" levels. In the first review period (2007-08 to 2009-10) these were set to 15% (M_p) and 12% (M_{op}). These were the values used for the calculation of the 2008-09 costs published by Western Power.

Recently the ERA has determined that these margins should be increased to 30% (M_p) and 103% (M_{op})⁵². The equations above indicate that the Availability Costs should scale linearly with these values. Since we have used the peak values, this implies a doubling of costs (assuming all other parameters remain the same, including MCAP). Although MCAP is projected to change somewhat from the calibration of these Margin values, the majority of this increase in cost is attributed to Verve Energy's contract gas supply constraining more frequently with the introduction of the LMS100 high efficiency gas turbine units (peak periods). The resulting values are illustrated in the last three rows of Table 14.4.

Spinning Reserve Costs

It is apparent from Table 14.4 that the availability cost of spinning reserve reduces from the existing level. This is because of the cost allocation methodology currently applied by the WEM rules to the load following costs, which ROAM has assumed to apply to spinning reserve costs once the load following requirement is the larger of the two. Because the spinning reserve is entirely provided by the load following plant, only half of the availability cost is applied to the

⁵² Economic Regulation Authority, Western Australia, Ancillary Service Parameters Determination - Margin_Peak, Margin_Off-Peak and Cost_LR. 31 March 2010.

spinning reserve. It may be desirable to use a different cost allocation; this should be explored further in conjunction with the other areas requiring attention highlighted by this study.

Analysis

Figure 14.2 illustrates the availability costs for load following and spinning reserve, calculated with the updated $M_p = 30\%$. Availability costs of load following increase as the load following requirement increases. A significant increase in the load following cost occurs when the load following requirement exceeds the spinning reserve requirement. This occurs in 2014-15 in Scenario 1, and 2027-28 in Scenario 3. The load following requirement remains below the peak spinning reserve requirement of 220 MW (based upon the maximum load of Collie) in Scenarios 2 and 4 for the duration of the study, so the increases in load following costs are more moderate in these scenarios.

Figure 14.2 illustrates how the availability cost of spinning reserve increases initially from the existing value (2008-09) to the value with an increased M_p , but decreases thereafter. This is because an increasing proportion of the spinning reserve requirement is being met by the load following plant, decreasing the availability costs of spinning reserve. This means that some of the increase in cost of load following is offset by a decrease in the cost of spinning reserve, although different market participants are typically responsible for these components.

Scenario 1 appears to have a relatively constant spinning reserve availability cost; this is coincidental. The initial increase from the increasing M_p is offset by a large decrease in 2014-15 when the load following requirement exceeds the spinning reserve requirement (significantly reducing the availability costs of spinning reserve).

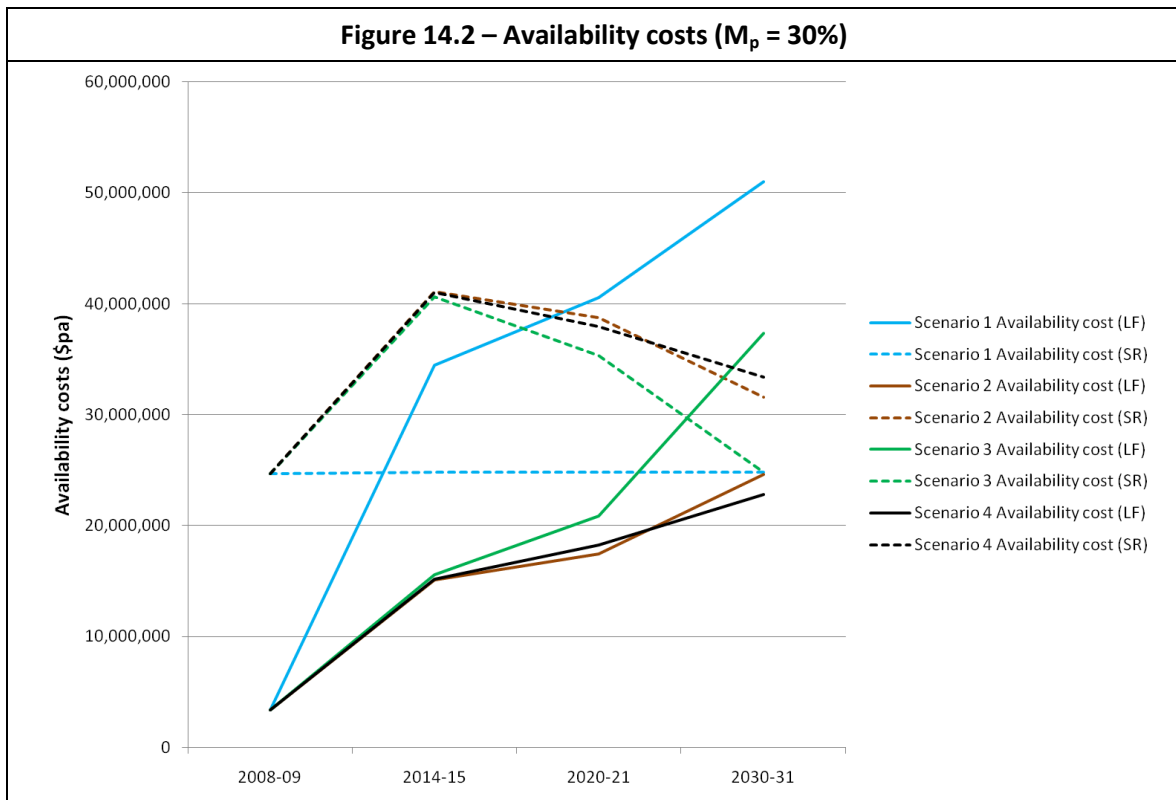

14.8.3) Total costs of load following

The Capacity Costs and Availability Costs projected for the load following service can be summed to produce the total load following costs listed in the following tables.

Table 14.8 – Load Following Costs (Scenario 1)

M_p	Year	Load following requirement (MW)	Capacity Cost of Load Following (\$ pa)	Availability Cost of Load Following (\$ pa)	Total Load Following Cost (\$ pa)
15%	2008-09 (as published)	60	6,441,298	3,381,721	9,823,019
15%	2014-15 (projected)	232	32,015,115	17,220,276	49,235,391
	2020-21 (projected)	256	35,316,552	20,274,719	55,591,271
	2030-31 (projected)	297	40,965,710	25,501,238	66,466,948
30%	2014-15 (projected)	232	32,015,115	34,440,552	66,455,667

	2020-21 (projected)	256	35,316,552	40,549,437	75,865,990
	2030-31 (projected)	297	40,965,710	51,002,475	91,968,185

Table 14.9 – Load Following Costs (Scenario 2)

M _p	Year	Load following requirement (MW)	Capacity Cost of Load Following (\$ pa)	Availability Cost of Load Following (\$ pa)	Total Load Following Cost (\$ pa)
15%	2008-09 (as published)	60	6,441,298	3,381,721	9,823,019
15%	2014-15 (projected)	134	18,490,537	7,550,819	26,041,356
	2020-21 (projected)	155	21,394,477	8,736,676	30,131,153
	2030-31 (projected)	218	30,125,621	12,302,137	42,427,758
30%	2014-15 (projected)	134	18,490,537	15,101,638	33,592,175
	2020-21 (projected)	155	21,394,477	17,473,352	38,867,829
	2030-31 (projected)	218	30,125,621	24,604,274	54,729,895

Table 14.10 – Load Following Costs (Scenario 3)

M _p	Year	Load following requirement (MW)	Capacity Cost of Load Following (\$ pa)	Availability Cost of Load Following (\$ pa)	Total Load Following Cost (\$ pa)
15%	2008-09 (as published)	60	6,441,298	3,381,721	9,823,019
15%	2014-15 (projected)	138	19,079,882	7,791,485	26,871,367
	2020-21 (projected)	185	25,557,160	10,436,554	35,993,714
	2030-31 (projected)	243	33,563,699	18,653,004	52,216,703
30%	2014-15 (projected)	138	19,079,882	15,582,970	34,662,852

	2020-21 (projected)	185	25,557,160	20,873,109	46,430,268
	2030-31 (projected)	243	33,563,699	37,306,008	70,869,706

Table 14.11 – Load Following Costs (Scenario 4)

M _p	Year	Load following requirement (MW)	Capacity Cost of Load Following (\$ pa)	Availability Cost of Load Following (\$ pa)	Total Load Following Cost (\$ pa)
15%	2008-09 (as published)	60	6,441,298	3,381,721	9,823,019
15%	2014-15 (projected)	135	18,574,729	7,585,200	26,159,929
	2020-21 (projected)	162	22,371,659	9,135,719	31,507,378
	2030-31 (projected)	203	27,949,046	11,413,308	39,362,354
30%	2014-15 (projected)	135	18,574,729	15,170,400	33,745,129
	2020-21 (projected)	162	22,371,659	18,271,438	40,643,097
	2030-31 (projected)	203	27,949,046	22,826,616	50,775,662

These costs are illustrated in Figure 14.3. Costs increase substantially over time as the load following requirement grows, particularly in Scenario 1 with very high wind penetration.

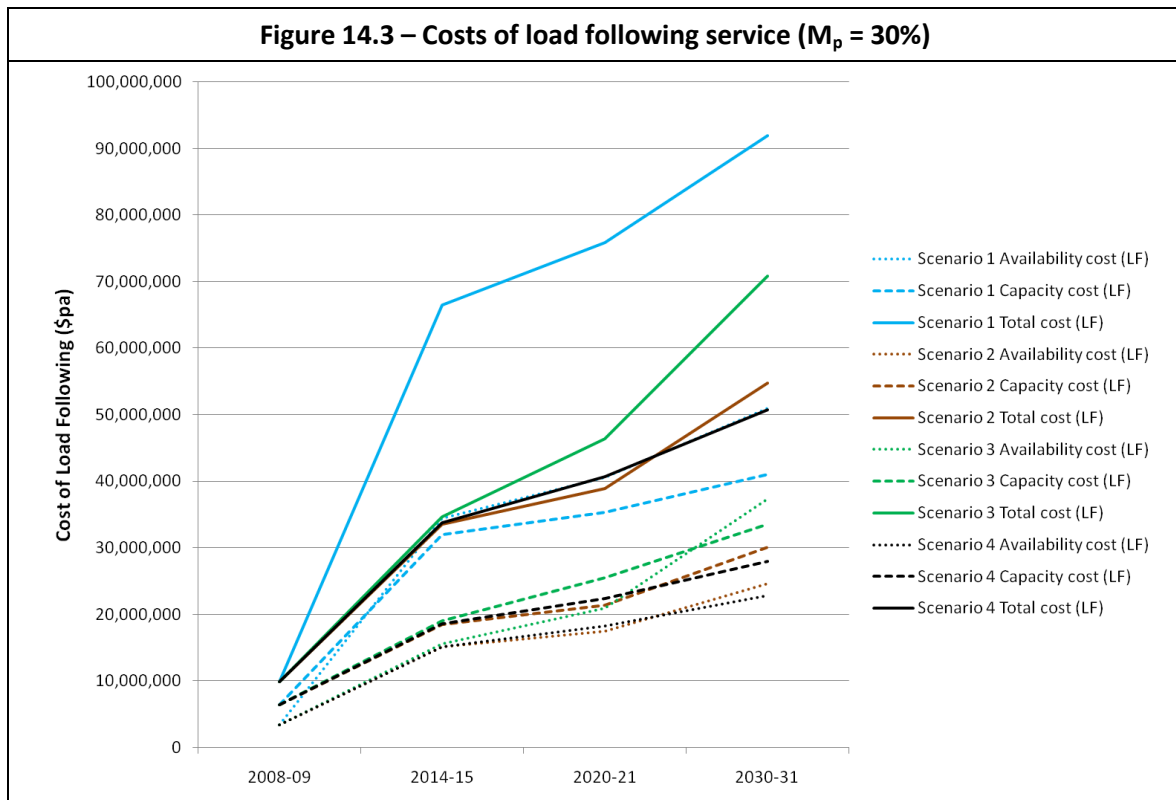

14.9) CALCULATION OF COSTS FROM DISPATCH MODELLING

To provide a comparison to the above method, ROAM performed dispatch modelling for Scenario 2 to calculate the availability costs of the load following service from first principles. These costs are not based upon the existing rule structure, but rather are an indication of the actual costs that Verve is likely to face if they must continue to provide the load following service under the existing Rules.

The earlier availability cost calculation (section 14.8.2) is based upon the assumption that existing market conditions continue. The alternative calculation provides an investigation of the sensitivity of these costs to various external factors, such as a rising gas price, or the application of a carbon price.

Methodology for dispatch modelling

ROAM has constructed a database that includes all existing and future generators in the SWIS, corresponding to the planting schedule for Scenario 2. Market data on the sent-out capacities, heat rates, fuel costs, and other significant factors affecting their operation were collected and used to construct generator bids. A half hourly demand profile was created, as described earlier in this report (section 6.2). Wind traces for individual wind farms were similarly created (section 6.1).

The dispatch merit order described earlier (section 8) was applied. This was essentially:

1. Load following plant is dispatched first, followed by:
2. Wind generation (quantity available at the time based upon wind traces) (SRMC)
3. Cogeneration plant
4. Coal-fired generation (includes NewGen Kwinana) to minimum loads
5. CCGT plant to minimum loads
6. Coal-fired generation to maximum loads (at SRMC)
7. CCGT plant to maximum loads (at SRMC)
8. OCGT plant to maximum loads (at SRMC)
9. Diesel and DSM (at SRMC)

Short run marginal costs (SRMCs) were calculated based upon a -5% carbon price trajectory. The following gas prices were assumed, based upon gas price projections and contract positions:

- Verve - \$3/GJ, rising to \$9/GJ from 2015
- Existing IPPs⁵³ - \$4/GJ
- New entrant IPPs - \$6/GJ, rising to \$9/GJ from 2015.

Two scenarios were simulated:

1. Scenario 2 with load following plant required in each year dispatched to the mid-point between their minimum and maximum load
2. Scenario 2 without load following plant operating (no load following)

Simulations were run on a half-hourly basis to determine:

- Half hourly price
- Half hourly volume of operation of each generator
- Half hourly costs of each generator (fixed operations and maintenance, variable operations and maintenance)

The availability cost was then calculated according to the following equation on a half hourly basis⁵⁴:

$$\text{Availability cost} = \text{GenCost}_{LF} - \text{GenCost}_{NLF} + (\text{GenVol}_{NLF} - \text{GenVol}_{LF}) \times \text{MCAP}_{LF}$$

where:

- GenCost_{LF} = Verve Energy's total generation costs in scenario with load following
- GenCost_{NLF} = Verve Energy's total generation costs in scenario without load following
- GenVol_{NLF} = Verve Energy's total generation volume in scenario without load following
- GenVol_{LF} = Verve Energy's total generation volume in scenario with load following
- MCAP_{LF} = System marginal price in scenario with load following

⁵³ IPP: Independent Power Provider

⁵⁴ Methodology equivalent to that used for calculation of Margin_{peak} and Margin_{off-peak}. MMA Report to Independent Market Operator of Western Australia, "2009 Margin_{Peak} and Margin_{Off-Peak} review, Final Report v.4.0". 10 December 2009.

This allows determination of the costs that Verve Energy is likely to incur from providing the load following service. It is assumed for this analysis that load following continues to be provided only by Verve (as is likely under the existing Rules).

Results of dispatch modelling

Table 14.12 shows the availability costs of load following as calculated using a first principles dispatch model. Key input assumptions that change over the course of the study are also listed in the table to illustrate their impacts on availability costs.

Year	Load Following Requirement (MW)	Plant providing load following	SMP (\$/MWh)	Verve gas price (\$/GJ)	Carbon price (\$/tCO ₂ -e)	Availability cost of load following (\$M)
2009-10	65	Pinjar GT11, Pinjar GT10	24	3	0	30.7
2010-11	67	Pinjar GT11, Pinjar GT10	26	3	0	30.3
2011-12	72	LMS100 U1, LMS100 U2	34	3	10	7.9
2012-13	99	LMS100 U1, LMS100 U2, Pinjar GT11	46	3	26	19.5
2013-14	134	LMS100 U1, LMS100 U2, Pinjar GT11, Pinjar GT10	47	3	28	31.4
2014-15	134	LMS100 U1, LMS100 U2, Pinjar GT11, Pinjar GT10	49	3	29	28.6
2015-16	135	LMS100 U1, LMS100 U2, Pinjar GT11, Pinjar GT10	56	9	31	171.5
2016-17	150	LMS100 U1, LMS100 U2, Pinjar GT11, Pinjar GT10	58	9	33	167.2
2017-18	151	LMS100 U1, LMS100 U2, Pinjar GT11, Pinjar GT10	60	9	35	163.9

2018-19	152	LMS100 U1, LMS100 U2, Pinjar GT11, Pinjar GT10	63	9	36	161.0
2019-20	154	LMS100 U1, LMS100 U2, Pinjar GT11, Pinjar GT10	64	9	38	160.3
2020-21	155	LMS100 U1, LMS100 U2, Pinjar GT11, Pinjar GT10	67	9	40	158.4
2021-22	156	LMS100 U1, LMS100 U2, Pinjar GT11, Pinjar GT10	69	9	41	158.6
2022-23	165	LMS100 U1, LMS100 U2, Pinjar GT11, Pinjar GT10, Pinjar GT9	67	9	43	215.7
2023-24	166	LMS100 U1, LMS100 U2, Pinjar GT11, Pinjar GT10, Pinjar GT9	66	9	45	222.5
2024-25	168	LMS100 U1, LMS100 U2, Pinjar GT11, Pinjar GT10, Pinjar GT9	69	9	47	219.7
2025-26	169	LMS100 U1, LMS100 U2, Pinjar GT11, Pinjar GT10, Pinjar GT9	77	9	48	203.1
2026-27	171	LMS100 U1, LMS100 U2, Pinjar GT11, Pinjar GT10, Pinjar GT9	80	9	50	198.5
2027-28	173	LMS100 U1, LMS100 U2, Pinjar GT11, Pinjar GT10, Pinjar GT9	83	9	52	194.3

2028-29	216	LMS100 U1, LMS100 U2, Pinjar GT11, Pinjar GT10, Pinjar GT9, Pinjar GT7, Pinjar GT5	83	9	54	227.9
2029-30	217	LMS100 U1, LMS100 U2, Pinjar GT11, Pinjar GT10, Pinjar GT9, Pinjar GT7, Pinjar GT5	85	9	56	228.5

The cost of load following is strongly affected by Verve's gas price (see Figure 14.4). When the gas price increases from \$3/GJ to \$9/GJ in 2015, the cost of load following increases substantially from \$29 million to \$172 million⁵⁵.

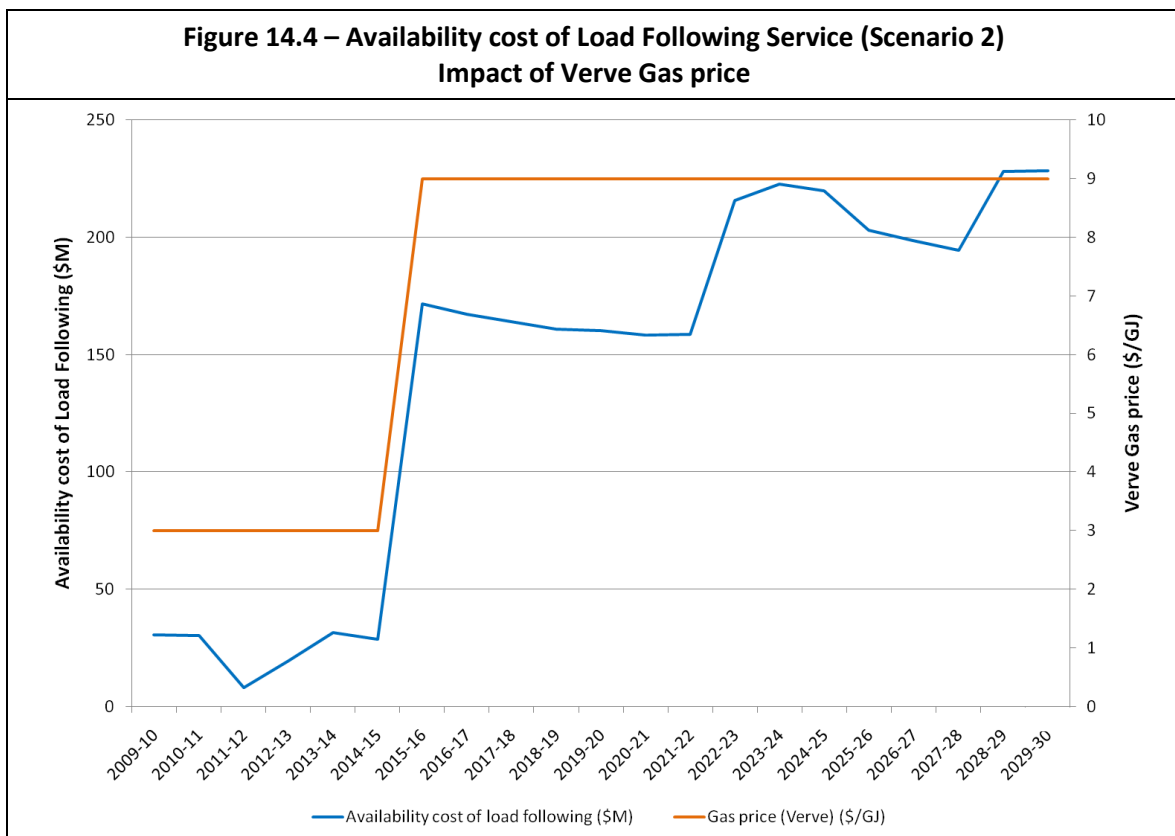

⁵⁵ The gas price increase featured in this diagram is simply a graphical representation of the input assumption used for the modelling, to demonstrate the impact that it has on availability costs of load following. The increase in gas price increases MCAP, which is incorporated into the calculation of the availability cost.

The increasing load following requirement is also a significant driver of increases in the availability cost of load following (see Figure 14.5). The cost decreases in 2011-12 due to the installation of the two new LMS100 units which can provide load following at a much higher efficiency, with a much smaller total quantity of plant online (these units are much more efficient than the Pinjar units that were used to provide load following in the previous year).

In 2022-23 the load following requirement increases by a small amount, causing a much larger corresponding increase in the load following cost. This is due to the necessity of bringing online the Pinjar GT9 unit for the additional 10 MW of load following, which was not previously required. Similarly in 2028-29 the Pinjar GT7 and GT5 units must be added to provide the load following required, substantially increasing costs.

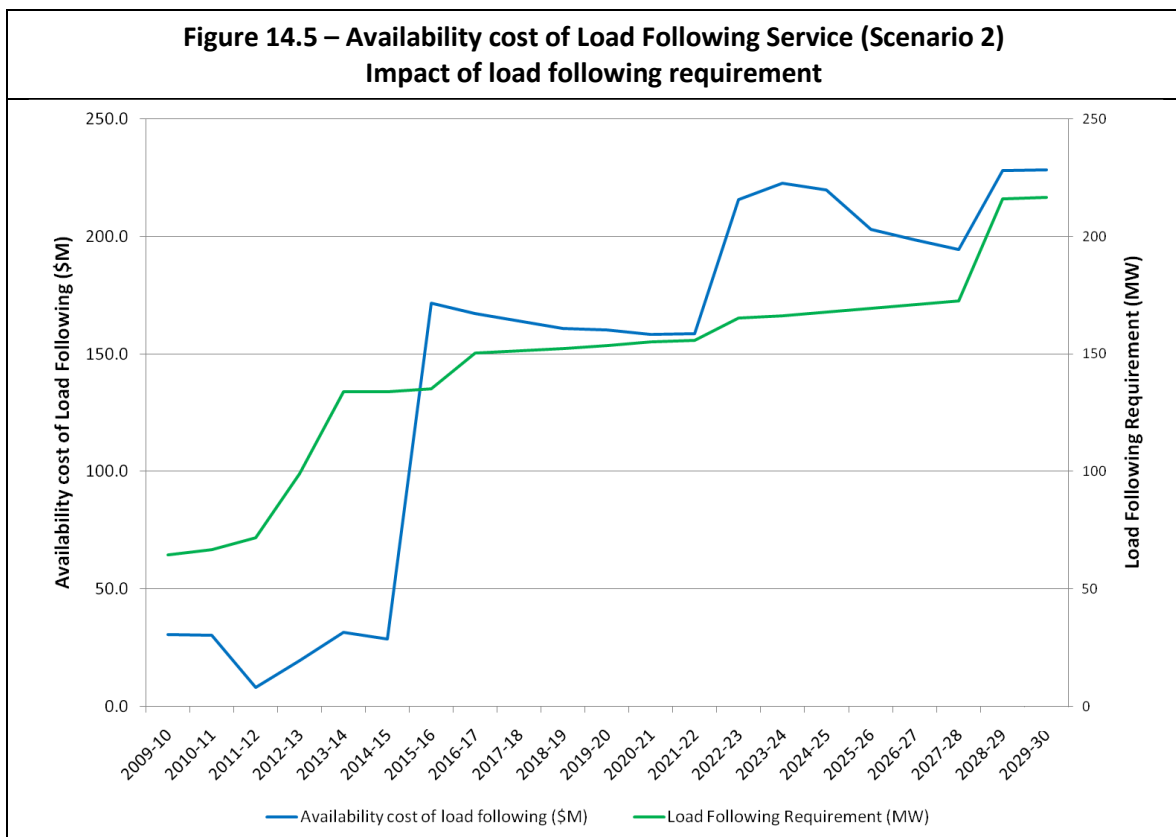

The cost of load following is also affected by an applied carbon price (see Figure 14.6) in a slightly more complicated manner. The carbon price acts to increase the costs of all generators in the system, increasing the system marginal price from \$24 /MWh in 2009-10 to \$85 /MWh in 2029-30. If Verve's generation volumes remain similar (competitiveness is maintained despite the increased carbon price) this then *decreases* the "cost" of load following to Verve, as calculated via the existing methodology. This is because the existing calculation of "cost" is actually based upon a compensation mechanism (refer to equation above for calculating availability cost). Verve is compensated for their increase in costs when providing the Load Following service, offset by the amount of revenue that they can recover from the market from sales of energy. Since load following plant is generally less emissions intensive than other plant in the system, MCAP increases more rapidly than do Verve's Load Following costs. This could mean that, if load

following availability costs are calculated via the existing methodology, Verve could receive less compensation for load following services with the entry of a carbon price (because they will be receiving a higher proportion of their costs as revenue from the market). This effect explains the apparent gradual reductions in availability cost over time when other factors remain the same (load following requirement is not increasing substantially, and the gas price remains constant).

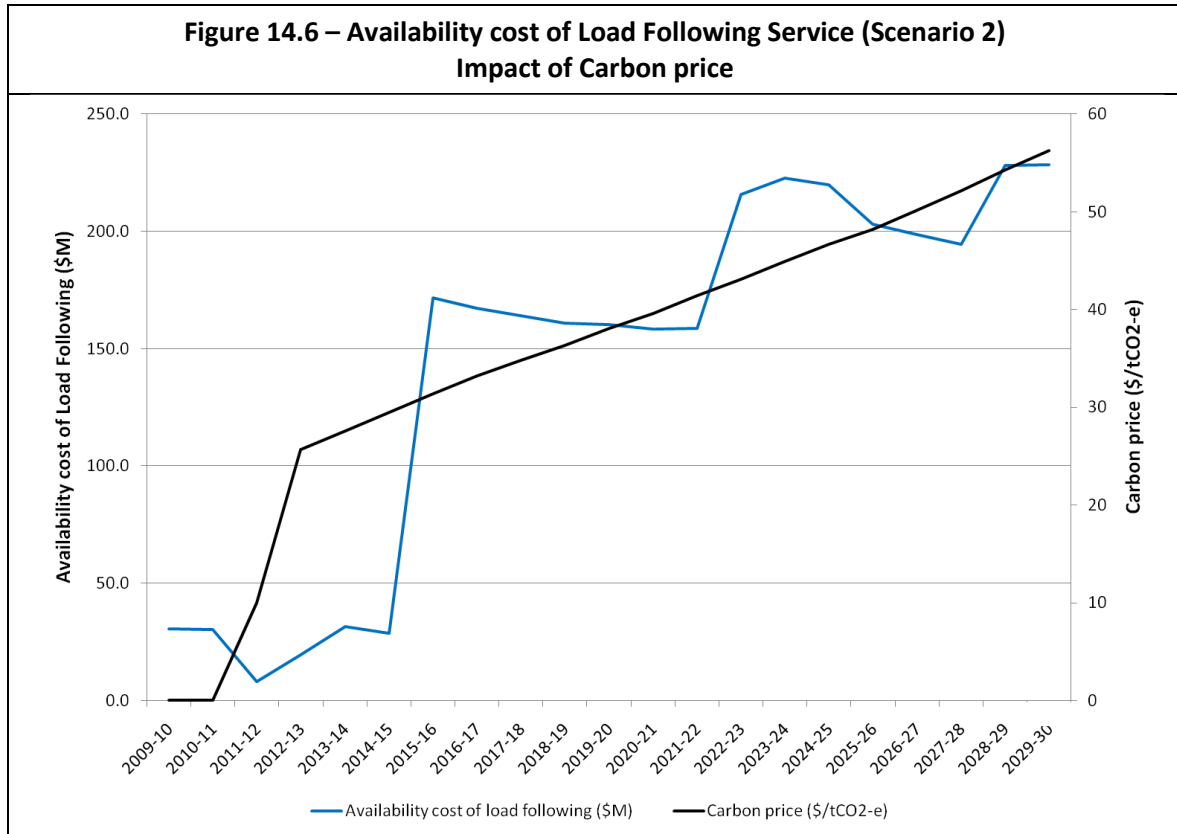

These factors mean that assumptions around gas prices and carbon prices (among other factors) are critical in any projection of costs of load following services. There is large uncertainty in these input assumptions, meaning that cost outcomes could vary widely.

Comparison of costs from dispatch model to those projected from existing costs

The availability costs calculated here are significantly larger than those calculated previously (section 14.8.2). This is partially due to the fact that the previous calculation assumes that market conditions remain relatively constant, where as this dispatch model assumes an applied carbon price and significantly increasing gas prices. Both of these have significant impacts on the availability cost.

In addition, the previously calculated costs are projected directly from costs published annually by Western Power for the load following service, and ROAM's analysis suggests that Western Power may be underestimating the true cost of providing this service (based upon the framework in the existing Rules).

Under the existing Rules the total availability cost of load following and spinning reserve is calculated based upon market modelling. The most recent analysis⁵⁶ calculates the aggregate availability cost of spinning reserve and load following to be \$30 to \$40 million pa for 2010-11 to 2012-13. Under the existing Rules this aggregate cost is then divided into spinning reserve and load following components based upon the relative sizes of these two requirements (60 MW of load following compared with 112 to 220 MW of spinning reserve). A further factor of a half is applied to the load following cost, since this cost is considered to be partially attributed to the spinning reserve service (load following plant simultaneously provides load following and spinning reserve). This means that the load following cost is likely to be only considered to contribute around 1/10th of the total availability cost (the rest being attributed to spinning reserve). This is reflected in the relative sizes of these costs published by Western Power⁵⁷ (\$3 million for load following availability, and \$25 million for spinning reserve in 2008/09).

ROAM's modelling, however, suggests that the costs of providing the load following service are likely to make up the majority of the availability cost, due to the more arduous nature of the service provided. Spinning reserve can be provided by any unit that is operating below maximum load, whereas for this analysis it has been assumed that load following can only be provided by a Verve OCGT operating at the mid-point between minimum and maximum loads (due to the fast response time required). Western Power states in their annual ancillary services report⁵⁸ that in 2008-09, the amount of spinning reserve generally exceeded the requirement, especially at night when units are left running on minimum output. This suggests that in the majority of periods sufficient spinning reserve service is available at zero cost (oversupplied). Attributing the majority of the availability cost to spinning reserve therefore appears to be a poor reflection of the division of actual costs.

Due to the different nature of the spinning reserve and load following services it is strongly recommended that a review of their relative costing in the Rules is undertaken. Although Verve can recover the same quantity of revenue regardless of the cost distribution, different market participants are responsible for the costs of load following and spinning reserve. This means that the relative proportions of the costs of these services is important.

Table 14.13 sums the availability cost to the capacity costs (refer to section 14.8.1) to determine the total cost of load following.

⁵⁶ MMA, Report to Independent Market Operator of Western Australia, "2009 Margin_Peak and Margin_Off-Peak review", Final Report v. 4.0, 10 December 2009.

⁵⁷ Western Power, "Ancillary Service Report 2009, prepared under clause 3.11.11 of the Market Rules by System Management - 28 May 2009".

⁵⁸ Western Power, "Ancillary Service Report 2009, prepared under clause 3.11.11 of the Market Rules by System Management - 28 May 2009".

Table 14.13 – Total costs of Load Following (Scenario 2)

Year	Availability costs of LF	Capacity costs of LF	Total costs of LF
2009-10	30,654,811	7,007,508	37,662,319
2010-11	30,250,988	9,598,865	39,849,853
2011-12	7,914,264	9,462,646	17,376,911
2012-13	19,471,259	13,685,095	33,156,354
2013-14	31,375,058	18,472,594	49,847,652
2014-15	28,588,743	18,490,537	47,079,280
2015-16	171,503,886	18,675,483	190,179,370
2016-17	167,193,939	20,741,643	187,935,582
2017-18	163,855,280	20,875,522	184,730,802
2018-19	160,954,546	21,009,401	181,963,947
2019-20	160,284,109	21,205,390	181,489,499
2020-21	158,351,186	21,394,477	179,745,663
2021-22	158,553,423	21,493,851	180,047,275
2022-23	215,682,715	22,800,901	238,483,615
2023-24	222,497,908	22,945,822	245,443,730
2024-25	219,661,340	23,143,190	242,804,531
2025-26	203,079,539	23,369,543	226,449,082
2026-27	198,503,613	23,577,953	222,081,566
2027-28	194,290,874	23,834,670	218,125,544
2028-29	227,924,688	29,810,935	257,735,624
2029-30	228,461,254	29,908,930	258,370,184

A.1) DIFFERENCES IN PROJECTED COSTS OF LOAD FOLLOWING - SUMMARY

In this report two methods have been used to project the future availability costs of load following:

First method - Existing Rules

Western Power publishes the costs of load following on an annual basis. Using the published availability cost of providing load following in 2008-09, ROAM projected forward the cost of providing the load following service to future years using the existing equations in the rules⁵⁹. By these equations, the availability cost scales linearly with the magnitude of the load following requirement. All other variables were assumed to remain constant, including MCAP (the market price in each trading interval). This captures increases in costs due to the increase in the load following requirement only (since all other variables remain constant).

Second method - Dispatch modelling

A dispatch model was used to directly determine the costs of providing the load following service. Two simulations were run; one with Verve plant providing load following, the second with no load following service provided. The availability cost of load following was then calculated as the difference in cost for Verve plant between the two scenarios, minus any additional revenue that they may have recovered from running load following plant⁶⁰.

$$\text{Availability cost}_{LF} = (\text{Gencost}_{LF} - \text{Gencost}_{NLF}) - (\text{GenVol}_{LF} - \text{GenVol}_{NLF}) \times \text{MCAP}$$

These two methods give answers that differ by a large margin. For example, in Scenario 2, the availability cost of load following in 2029-30 was calculated to be ~\$25 million by the first method, but ~\$230 million by the second method⁶¹. This difference is not an error, but rather provides important insight. The difference occurs for two reasons:

Primary reason - Assumptions in the rules regarding spinning reserve

In the existing WEM rules, the following process is used to calculate costs of load following. Every few years, dispatch modelling is performed to calculate the costs of load following and spinning reserve (similar to the "second method" described above, except that spinning reserve is also included). This modelling is used to calibrate two factors: Margin_peak and Margin_offpeak.

⁵⁹ Minor corrections were applied to the existing rules to make this projection possible. Two minor errors were identified. The first involved adding a term to account for load following provided by contract (non-Verve plant). The second involved allowing for the situation where the load following requirement exceeds the spinning reserve requirement.

⁶⁰ This was calculated as the difference in Verve's generator volumes (MWh) between the two scenarios, multiplied by the price in each trading interval.

⁶¹ The availability cost is summed with a capacity cost to calculate the total cost of load following. Capacity costs for Scenario 2 were calculated to be ~\$30 million in 2029-30.

These two factors are then used to calculate availability costs of load following and spinning reserve according to the following equations (summed over every trading interval).

$$\text{Availability cost}_{LF} = 0.5 \times \text{Margin}_{\text{peak/off-peak}} \times \text{MCAP} \times (0.5 \times \text{Requirement}_{LF})$$

$$\begin{aligned} \text{Availability cost}_{SR} &= 0.5 \times \text{Margin}_{\text{peak/offpeak}} \times \text{MCAP} \\ &\times (\text{Requirement}_{SR} - 0.5 \times \text{Requirement}_{LF}) \end{aligned}$$

This method calculates the cost of providing load following and spinning reserve simultaneously (in a single dispatch model run), and then assumes that the relative costs of these two services is proportional to the relative sizes of the two requirements. Since at the moment the load following requirement is much smaller than the spinning reserve requirement, this yields load following costs that are much smaller than spinning reserve costs. In addition, half of the cost of load following is attributed to spinning reserve, since plant providing load following service simultaneously provides spinning reserve.

For example, in 2008-09, Western Power published a total availability cost of \$28.1 million⁶². \$3.4 million of this (11%) was attributed to load following, compared with \$24.7 million (89%) for spinning reserve. This is due to a 60 MW load following requirement, half of which is attributed to spinning reserve (since load following plant simultaneously provides a spinning reserve service). By comparison, the spinning reserve requirement is likely to be close to 220 MW in peak times (70% of the capacity of Collie).

Importantly, the 'first method' used by ROAM (projecting forward costs using the existing rules) perpetuates this distribution of costs between spinning reserve and load following. By comparison, the dispatch modelling (the second method) does not. In the dispatch modelling exercise (the second method) the cost of load following was calculated independent of the cost of spinning reserve. The cost of load following alone in 2009-10 calculated via the dispatch model was calculated to be \$30.7 million. This is very close to the total availability cost (spinning reserve plus load following) as published by Western Power for 2008-09 (\$28.1 million). This indicates that the majority of the total availability cost is due to load following, with a minimal contribution from spinning reserve. This is supported by the fact that a very small number of periods in the dispatch model would have required additional spinning reserve beyond that available at zero cost or from the existing load following service (even though spinning reserve was not being modelled explicitly in this exercise).

The discrepancy between the costs calculated via the two methods therefore indicates that the methodology in the WEM rules for dividing costs between spinning reserve and load following is likely to be significantly flawed. The load following service is likely to be more arduous to provide, requiring constant dispatch of fast response plant above minimum loads with constant adjustment. This is particularly expensive during overnight periods when the MCAP is low and

⁶² Western Power, Ancillary Service Report 2009, prepared under clause 3.11.11 of the Market Rules by System Management - 28 May 2009.

OCGT plant is dispatched far out of merit order. By comparison, spinning reserve is provided at zero cost in many periods, particularly overnight when many generators are ramped down to minimum load (Western Power state in their 2008-09 report that the amount of spinning reserve generally exceeded the requirement).

Secondary reason - Differences in input assumptions

There were some differences in input assumptions between the two methods, and the cost calculation is sensitive to these. The most significant differences included:

- **Gas prices** - In the first method existing gas prices and contracts were continued. In the second method, gas prices were assumed to be the following. Verve: \$3/GJ, rising to \$9/GJ from 2015. Existing IPPs: \$4/GJ. New entrant IPPs: \$6/GJ, rising to \$9/GJ from 2015.
- **Carbon price trajectory** - a -5% carbon price trajectory was included in the second method, whereas no carbon price was assumed for the first method.

These will increase the cost to Verve plant, but also simultaneously increase the MCAP. Since increasing MCAP increases revenue recovered by Verve plant, this offsets some of the increase in availability cost (refer to previous equation). This limits the impact of changes in these variables.

Dispatch modelling for Scenarios 1, 3 and 4

In this report ROAM has calculated costs via the first method for all four scenarios. By contrast, the dispatch modelling method was applied to Scenario 2 only. This is because the first method was determined to provide more insight into changes that may be required in the WEM Rules (three distinct flaws were identified via this process).

Although it is possible to provide dispatch modelling calculations for the remaining three scenarios, it is unlikely that this will provide much further insight and understanding. Inconsistencies and areas of the Rules that require immediate attention have been identified, and are unlikely to be further enlightened through the analysis of more scenarios. ROAM recommends that the insights from this study are used to refocus attention on areas that need to be addressed as a priority, and areas where further important questions remain.

14.10) ALLOCATION OF COSTS

Existing allocation of costs

In the existing system the IMO allocates the cost of ancillary services between Market Participants on the following basis:

1. The monthly cost of load following will be allocated amongst Market Participants in proportion to their monthly contributing quantity, where this quantity comprises the sum of the Market Participant's metered load and metered Non-Scheduled Generation. Load following costs are not allocated to Scheduled Generation.
2. The monthly costs of spinning reserve is borne by generators in proportion to the deemed risk that the generator imposes on the system, based on the output of the generator in each Trading Interval during the month.

3. The monthly costs for Load Rejection Reserve, Dispatch Support and System Restart are recovered from Market Customers in proportion to their monthly metered consumption.

Causer pays principle

The Energy Supply Association of Australia (ESAA) recently advised⁶³:

"In relation to the funding of ancillary services, it is important that cost allocation is guided by the causer pays principle...This issue may become increasingly relevant as the penetration of intermittent generation increases in response to climate change policies, for example, the cost of back up generation for wind power."

The report recommended that the WA Government should implement a causer pays model for ancillary services where possible. Depending on the changes, this may impact on intermittent generators who are more likely to cause unexpected operation.

A recent report by Econnect⁶⁴ recommended that wind generators be responsible for the marginal increase in the cost of load following due to the variability of wind generation. This prevents system loads from obtaining a "windfall" benefit via reduced load following costs as wind is added to the system (accumulating an increasing share of the load following costs). Under this method loads would be charged for their full variability, and wind generation would only be charged for variability (or load following requirements) in excess of that amount.

This allocation methodology is recommended on the basis that managing the variability of intermittent loads is inherent in operating the system. In the absence of intermittent generation, intermittent loads would be required to pay for their full frequency control requirements, and would then receive a windfall gain if intermittent generation was added to the system. It could then be considered "fairer" if the charge for load following service reflected the past history of connections. This is problematic, however, since it subjects those who connect earlier to an ongoing higher penalty⁶⁵.

Paying the marginal cost of load following (in excess of the load following required by intermittent loads) allows intermittent generators to pay only for the load following services they require in excess of what is already required by loads (inherently required by the system). This is considered to be accurately representative of the cost burden that intermittent generators place on the system, and an appropriate price signal for wind generators. ROAM believes this to be a relatively fair and efficient approach.

⁶³ ESAA report, *Western Australian Energy Market Study*, Nov 2009

⁶⁴ Econnect, South West Interconnected System (SWIS), Maximising the Penetration of Intermittent Generation in the SWIS. Econnect Project No: 1465, prepared for Office of Energy, Western Australia. August 2005.

⁶⁵ Econnect, South West Interconnected System (SWIS), Maximising the Penetration of Intermittent Generation in the SWIS. Econnect Project No: 1465, prepared for Office of Energy, Western Australia. August 2005.

Future allocation of costs

ROAM has applied a marginal approach to load following costs, applying the full cost of the variability of demand to system loads, and applying only the variability in addition to this to intermittent generators.

Based upon ROAM's calculations of the proportion of load following requirement from loads and wind generation in isolation, the proportions listed in Table 14.14 and Table 14.15 result.

M _p	Year	Total Load Following Cost (\$ pa)	Proportion of cost to Loads	Proportion of cost to Intermittent Generators	Cost to Loads (\$ pa)	Cost to Intermittent Generators (\$ pa)
15%	2014-15	49,235,391	31%	69%	15,119,782	34,115,609
	2020-21	55,591,271	38%	62%	21,167,830	34,423,441
	2030-31	66,466,948	46%	54%	30,657,071	35,809,877
30%	2014-15	66,455,667	31%	69%	20,407,986	46,047,681
	2020-21	75,865,990	38%	62%	28,887,959	46,978,031
	2030-31	91,968,185	46%	54%	42,419,206	49,548,979

M _p	Year	Total Load Following Cost (\$ pa)	Proportion of cost to Loads	Proportion of cost to Intermittent Generators	Cost to Loads (\$ pa)	Cost to Intermittent Generators (\$ pa)
15%	2014-15	26,041,356	52%	48%	13,658,640	12,382,716
	2020-21	30,131,153	60%	40%	18,155,278	11,975,875
	2030-31	42,427,758	58%	42%	24,702,862	17,724,896
30%	2014-15	33,592,175	52%	48%	17,619,029	15,973,146
	2020-21	38,867,829	60%	40%	23,419,491	15,448,338
	2030-31	54,729,895	58%	42%	31,865,579	22,864,317

These costs are listed in dollars per megawatt of wind capacity installed, and in dollars per megawatt hour of wind generation (assuming a 40% capacity factor) in Table 14.16 and Table 14.17. By these metrics costs are highest in the early years, because the wind variability increases steeply with the initial installation of wind. The load following requirement increases more slowly

as more wind is added to the system, allowing the load following costs to be spread across a larger number of intermittent generators.

M_p	Year	Cost to Intermittent Generators (\$ pa)	Installed wind capacity (MW)	Cost to Intermittent Generators (\$/MW pa)	Cost to Intermittent Generators (\$/MWh)
15%	2014-15	34,115,609	826	41,317	\$12
	2020-21	34,423,441	1,046	32,919	\$9
	2030-31	35,809,877	1,776	20,167	\$6
30%	2014-15	46,047,681	826	55,768	\$16
	2020-21	46,978,031	1,046	44,925	\$13
	2030-31	49,548,979	1,776	27,904	\$8

M_p	Year	Cost to Intermittent Generators (\$ pa)	Installed wind capacity (MW)	Cost to Intermittent Generators (\$/MW pa)	Cost to Intermittent Generators (\$/MWh)
15%	2014-15	12,382,716	576	21,509	\$6
	2020-21	11,975,875	704	17,018	\$5
	2030-31	17,724,896	1,086	16,326	\$5
30%	2014-15	15,973,146	576	27,746	\$8
	2020-21	15,448,338	704	21,953	\$6
	2030-31	22,864,317	1,086	21,060	\$6

These costs are significant, and may be sufficient to deter wind penetration in the SWIS (in favour of less expensive sites in the NEM, or other parts of Australia). However, wind farms in the SWIS generally achieve excellent capacity factors (~40%), which are substantially better than those in other parts of Australia (compare with 30% for South Australian wind farms). This increased capacity factor is likely to more than outweigh additional ancillary services costs of this magnitude, allowing wind penetration in the SWIS to continue to grow.

Although these costs are calculated using the existing WEM rules, ROAM does not believe that they are representative of the actual costs of providing the load following service if more efficient methods of providing this service are explored. It is inefficient to expect Verve to continue to provide the entire load following service with a diminishing proportion of installed capacity in the

SWIS. Introducing an efficient market for ancillary services in the SWIS is of very high importance, and likely to be necessary to allow penetration of wind generation into this market.

Costs calculated from dispatch modelling

Costs calculated by dispatch modelling (as described in section 14.9) are illustrated for Scenario 2 in Table 14.18, with allocation to intermittent generators.

Table 14.18 – Allocation of costs of Load Following (Scenario 2) - Dispatch modelling outcomes							
Year	Availability costs of LF	Capacity costs of LF	Total costs of LF	Proportion paid by wind (marginal)	Installed capacity of wind (MW)	\$/MW pa paid by wind	\$/MWh paid by wind
2009-10	30,654,811	7,007,508	37,662,319	23%	191	46086	\$18
2010-11	30,250,988	9,598,865	39,849,853	20%	191	42022	\$17
2011-12	7,914,264	9,462,646	17,376,911	13%	191	12049	\$5
2012-13	19,471,259	13,685,095	33,156,354	35%	326	35236	\$14
2013-14	31,375,058	18,472,594	49,847,652	49%	576	42486	\$17
2014-15	28,588,743	18,490,537	47,079,280	48%	576	38885	\$15
2015-16	171,503,886	18,675,483	190,179,370	44%	576	146508	\$58
2016-17	167,193,939	20,741,643	187,935,582	48%	684	132148	\$52
2017-18	163,855,280	20,875,522	184,730,802	46%	684	123649	\$49
2018-19	160,954,546	21,009,401	181,963,947	44%	704	112546	\$44
2019-20	160,284,109	21,205,390	181,489,499	41%	704	106381	\$42
2020-21	158,351,186	21,394,477	179,745,663	40%	704	101523	\$40
2021-22	158,553,423	21,493,851	180,047,275	38%	704	96217	\$38
2022-23	215,682,715	22,800,901	238,483,615	39%	836	110849	\$44
2023-24	222,497,908	22,945,822	245,443,730	36%	836	107021	\$42
2024-25	219,661,340	23,143,190	242,804,531	35%	836	101970	\$40
2025-26	203,079,539	23,369,543	226,449,082	34%	836	91203	\$36
2026-27	198,503,613	23,577,953	222,081,566	32%	836	86118	\$34
2027-28	194,290,874	23,834,670	218,125,544	31%	836	80650	\$32
2028-29	227,924,688	29,810,935	257,735,624	43%	1036	108094	\$42
2029-30	228,461,254	29,908,930	258,370,184	42%	1086	99418	\$39

These costs are substantial (\$40 - \$60 /MWh), and are likely to be sufficient to deter wind penetration in the SWIS. If these higher costs are an accurate reflection of actual costs likely to eventuate for the provision of load following services in the SWIS, it is highly recommended that opportunities to minimise these costs are investigated. It is emphasised that these costs represent a "worst" case scenario, where none of the known opportunities for increased efficiency for the provision of this service have been implemented.

Opportunities for minimising costs could include:

- Implementing a competitive market for ancillary services, allowing utilisation of the most efficient plant for provision of load following
- Utilising plant other than OCGT plant for load following
- Utilising plant other than Verve plant for load following
- Investigating new technologies specifically designed for load following service (for example, the LMS100 units dramatically reduce load following costs)
- Investigating opportunities to minimise load following requirements, such as through
 - Effective wind forecasting
 - Allowing expanded frequency limits
 - More nuanced management of aggregate intermittent generation

14.10.1) Revision of WEM Rules

Implementing cost allocation for Load Following in this manner will require revision of the WEM Rules clause 3.14.1.

3.14.1. Market Participant p 's share of the Load Following Service payment cost in each Trading Month m is $Load_Following_Share(p,m)$ which equals is given by:

$$Load_Following_Share(p,m) = \frac{(MS_Loads(p,m) \times LFR_Loads(m)) + (MS_Gens(p,m) \times (LFR(m) - LFR_Loads(m)))}{(MS_Loads_total(m) \times LFR(m)) + (MS_Gens_total(m) \times LFR(m))}$$

(a) the Market Participant's contributing quantity; divided by

(b) the total contributing quantity of all Market Participants,

where a Market Participant's contributing quantity for Trading Month m is the sum of: i.

where

$MS_Loads(p,m)$ is the absolute value of the sum of the Metered Schedules for the Non-Dispatchable Loads, Interruptible Loads, and Curtailable Loads registered by the Market Participant p for all Trading Intervals during Trading Month m

MS_Loads_total(m) is the absolute value of the sum of the Metered Schedules for the Non-Dispatchable Loads, Interruptible Loads, and Curtailable Loads registered by all Market Participants

and ii.

MS_Gens(p,m) is the sum of the Metered Schedules for Non-Scheduled Generators registered by the Market Participant p for all Trading Intervals during Trading Month m

iii. [Blank]

MS_Gens_total(m) is the sum of the Metered Schedules for Non-Scheduled Generators registered by all Market Participants during Trading Month m

LFR(m) is the capacity necessary to cover the Ancillary Services Requirement for Load Following for Trading Month m as specified by the IMO under clause 3.22.1(fA);

LFR_Loads(m) is the capacity that would be necessary to cover the Ancillary Services Requirement for Load Following for the Trading Month m as specified by the IMO under clause 3.22.1(fA) if there were no Non-Scheduled Generators, and all variability was due to fluctuations in the load. This is calculated as outlined in clause 3.10.1(a) by setting the output of Non-Scheduled Generators and uninstructed output fluctuations from Scheduled Generators are zero at all times.

15) MODERATION OF INTERMITTENT GENERATORS TO REDUCE LOAD FOLLOWING REQUIREMENT

There is currently a requirement in the technical rules for the SWIS that non-scheduled generators do not increase or decrease their active power generation at a rate greater than 15% of the generator machine's nameplate rating per minute⁶⁶. ROAM conducted an analysis of the effectiveness of this requirement in limiting wind farm volatility (and therefore load following requirements), as illustrated below.

The 15% of capacity per minute limitation was applied to each wind farm trace individually, for the 2030-31 year of Scenario 1. It was assumed that wind farms can moderate an increase in output (through curtailment), but cannot moderate a decrease in output.

⁶⁶ Technical Rules for the South West Interconnected Network, Section 3, 3.3.3.5, b). p.62.

The load following requirement was found to be unchanged compared with the case where no ramp rate limit was applied (refer to Table 15.1). A 5% limit was similarly ineffective at reducing volatility, reducing the load following requirement by only 2 MW from 297 MW to 295 MW. Even a 1% limitation exhibited relatively little impact, reducing the load following requirement by only 21 MW. This is because with almost 1500 MW of wind installed, a 1% ramp limitation still permits an aggregate increase of 15 MW per minute, if all wind farms were to increase output simultaneously. Over a 30 minute period (which is the time frame relevant for the calculation of the existing load following metric) this amounts to a possible 438 MW increase in output.

In order to significantly impact the load following requirement it is necessary to apply a 0.2% ramp limitation. This reduces the load following requirement by 75 MW, and very substantially decreases the component that is due to wind variation. Notably, the load following requirement in the negative direction remains unchanged, since wind farms are assumed to be unable to moderate sudden decreases in output⁶⁷.

	Ramp rate limitation (% of wind farm capacity per minute)	Load and Wind		Wind only	
		Min	Max	Min	Max
Existing load following definition	None	-300	297	-277	294
	15%	-300	297	-277	295
	5%	-298	295	-275	290
	1%	-229	276	-253	219
	0.2%	-147	222	-204	91

A similar analysis has been performed with the alternative load following metrics, as illustrated in Table 15.2. The slow following requirement remains relatively unchanged regardless of any limitation on wind farm ramping, since this metric is dominated by shifts in load.

The regulation requirement responds similarly to the existing load following metric, but exhibits a greater response to a 1% limitation.

⁶⁷ In the case that a wind generator is already curtailed, they would be able to prevent a sudden decrease in output. It is assumed for this study that wind generation is rarely curtailed unless a wind farm specifically chooses to offer a load following service (discussed in section 16). Frequent curtailment of wind farms carries a large opportunity cost. If, however, wind farms were experiencing regular curtailment then they would be able to mitigate sudden decreases in output to the extent of their curtailment.

The fast response requirement is the most significantly affected, due to the short timeframe of this metric. A 0.2% limitation very substantially reduces the contribution of wind volatility to the fast response requirement (reduced from 50 MW to 3 MW).

	Ramp rate limitation (% of wind farm capacity per minute)	Load and Wind		Wind only	
		Min	Max	Min	Max
Slow Following	None	-1193	1241	-338	366
	15%	-1193	1241	-338	366
	5%	-1193	1241	-335	361
	1%	-1193	1244	-324	314
	0.2%	-1193	1254	-275	162
Regulation	None	-216	211	-190	204
	15%	-216	211	-190	204
	5%	-209	209	-188	196
	1%	-158	196	-170	129
	0.2%	-130	168	-130	48
Fast Response	None	-75	77	-48	50
	15%	-74	77	-48	50
	5%	-72	76	-47	38
	1%	-68	72	-35	15
	0.2%	-68	71	-21	3

These results indicate that ramp rate limits could be a useful tool to limit the volatility of wind farm output, if wind farm output is not curtailed too significantly. Based upon the calculated wind traces, ROAM found that to achieve a 15%/min limitation, negligible amounts of curtailment were necessary over the year, as illustrated in Table 15.3. A 5% limitation was similarly small (0.42%). However, neither of these limitation levels was effective at reducing the load following requirement by any metric.

A 1% limitation results in a 6% curtailment of aggregate wind farm output, and a 0.2% limitation results in a very substantial 21% curtailment of aggregate wind farm output. Neither of these curtailment levels are likely to be cost effective to wind farms.

Table 15.3 – Effect of limiting ramp rate (2030-31, Scenario 1) - existing metric

Ramp rate limitation (% wind farm capacity per minute)	Percentage of wind energy curtailed per annum (MWh)
15%	0.00%
5%	0.42%
1%	5.55%
0.2%	20.66%

These results indicate that the application of a constant ramp rate limitation sufficient to affect the load following requirement is likely to be prohibitively expensive to wind farms through lost revenue. Additionally, this level of curtailment is usually not required to maintain system security, since it is only necessary if all wind farms simultaneously increase output. These results suggest that a more nuanced approach to wind farm curtailment is likely to be necessary.

16) INTERMITTENT GENERATION PROVIDING ANCILLARY SERVICES

Wind farms can contribute to various aspects of ancillary services. The can contribute to:

- An inertial response (for fast response load following)
- Active frequency regulation (regulation) via active curtailment

These are explored in the following sections.

16.1) WIND FARMS CONTRIBUTING INERTIA

Some wind turbine technologies can provide an inertial response to the grid. At high penetration levels an inertial contribution from wind may become important to assist in arresting frequency rapid changes.

Wind turbines feature a large rotating turbine, which by its nature has stored kinetic energy. If the turbine is synchronised with the grid this kinetic energy can be a source of inertia. For example, fixed speed turbines (squirrel-cage induction generators, SCIG) are synchronised and therefore provide an inertial response. It has been shown that the introduction of a modest quantity of SCIG turbines can actually improve the frequency response of the system, since a relatively large capacity of wind is required to displace conventional generation⁶⁸.

⁶⁸ R. Doherty, A. Mullane, G. Nolan, D. Burke, A. Bryson, M. O'Malley, "An assessment of the Impact of wind generation on system frequency control". IEEE Trans. Power Sys., Vol 25, No. 1, 2010.

More modern turbine designs permit variable speed operation, which increases turbine efficiency (doubly-fed induction generators and full convertor generators). This is achieved by non-synchronous operation, which prevents the turbines contributing an inertial response to the system⁶⁹. There has been considerable interest in recent years in addressing this. It has been shown that through the addition of a control loop variable speed wind turbines can emulate an inertial response^{70 71}, and can therefore be used to assist with frequency control^{72 73 74}. The control loops can be designed to provide a much better controlled inertial response than that from SCIG turbines⁷⁵.

Frequency control features applied to wind turbines typically include a droop characteristic, providing similar behaviour in the event of a contingency to that of a conventional generator. Some grids with relatively high wind installation levels now require new wind installations to be capable of providing an inertial response of this nature (for example, the Irish Grid Code, the German Grid Code and the Great Britain Grid Code).

In order to provide an inertial response wind turbines must be physically turning. Recent analysis of wind in the Irish system indicates that when the total aggregated wind power output is greater than 20% of the installed wind capacity, 90% of the turbines are physically spinning and capable of providing kinetic energy to the power system during a frequency deviation event⁷⁶. Even variable speed turbines typically operate within a narrow range of rotational speed (15-19 rpm), so if the turbines are physically spinning they are providing their full capability of kinetic energy to the system.

Incentives for provision of inertia

This analysis indicates that wind turbines can feasibly provide an inertial response in the SWIS.

⁶⁹ A. Mullane, M. J. O'Malley, "The inertial response of induction machine based wind-turbines". IEEE Trans. Power Syst. vol. 20, pp.1496-1503, 2005.

⁷⁰ J. Ekanayake, N. Jenkins, "Comparison of the response of doubly-fed and fixed-speed induction generator wind turbines to changes in network frequency". IEEE Trans. Energy Convers. vol. 19, pp. 800-802, 2004.

⁷¹ J. Morren, S. de Haan, W. Kling, J. Ferreira, "Wind turbines emulating inertia and supporting primary frequency control". IEEE Trans. Power. Syst., vol. 21, no. 1, pp. 433-434, 2006.

⁷² N. Ullah, T. Thiringer, D. Karlsson, "Temporary primary frequency control support by variable speed wind turbines - Potential applications". IEEE Trans. Power. Syst. vol. 23, pp.601-612, 2008.

⁷³ J. Mauricio, A. Marano, A. Gomez-Exposito, J. Ramos, "Frequency regulation contribution through variable speed wind energy conversion systems", IEEE Trans. Power Syst. Vol 24, no. 1, pp.173-180, 2009.

⁷⁴ G. Lalor, A. Mullane, M. O'Malley, "Frequency control and wind turbine technologies". IEEE trans. power syst., Vol 20, no. 4, Nov 2005.

⁷⁵ P. Keung, P. Banakar, B. Ooi, "Kinetic energy of wind turbine generators for system frequency support, "IEEE Trans. Power. Syst., vol 24, no. 1 pp. 279-287, 2009.

⁷⁶ R. Doherty, A. Mullane, G. Nolan, D. Burke, A. Bryson, M. O'Malley, "An assessment of the Impact of wind generation on system frequency control". IEEE Trans. Power Sys., Vol 25, No. 1, 2010.

The frequency modelling included in this study (Section 11) suggests that an inertial response from wind generation may not be required in order to keep the frequency within required bounds, provided that all plant offering load following service also provide a sufficient governor response. However, if it becomes necessary to source more inertia for the SWIS, incentives for providing inertia could be considered in order to promote the preferential installation of synchronous wind turbines, or turbines with control loops capable of providing an inertial response.

Insufficient inertia should not be a limiting factor for the penetration of wind in the SWIS.

An alternative approach is to require all new wind installations to provide a degree of inertial response, although this may be unnecessarily constrictive on the developing wind industry in the SWIS and an inefficient way of producing the desired outcome. An inertial response is most important following a contingency event, which wind generation is unlikely to have caused. Wind generation contributes significantly to the load following (regulation) requirement, but does not contribute to the spinning reserve requirement^{77 78 79}. It therefore seems unfair to require wind generation to provide the desired inertial response. A market approach to sourcing the required inertia is likely to be more efficient.

16.2) CURTAILMENT TO PROVIDE REGULATION

It has been suggested that intermittent generators may be able to offer load following service by curtailing their output by a small margin^{80 81 82}.

16.2.1) Technical feasibility

Firstly, it must be considered whether it is technically feasible for intermittent generators to provide a load following service. They will need to be able to achieve the following:

1. Curtail output by a constantly adjustable amount

⁷⁷ G. Dany, "Power Reserve in Interconnected Systems with High Wind Power Production". IEEE Porto Power Tech Conference, Sept 2001.

⁷⁸ J. Duval, B. Meyer, "Frequency Behaviour of grid with high penetration rate of wind generation". IEEE Bucharest Power Tech Conference, 2009.

⁷⁹ H. Holtinen, R. Hirvonen, "Power System requirements for wind power ", in "Wind power in power systems", T. Ackermann editor, Ch. 8, pp.143-167, 2005.

⁸⁰ G. Ramtharan, J. Ekanayake, N. Jenkins, "Frequency support from doubly fed induction generator wind turbines". IEEE Renew. Power Gener., Vol 1, No. 1, pp. 3-9. 2007.

⁸¹ J. Ekanayake, L. Holdsworth, N. Jenkins, "Control of DFIG wind turbines", Power Engineer, 2003, Vol 17, No. 1, pp. 28-32

⁸² A. Mullane, M. O'Malley, "The inertial response of induction-machine-based wind turbines", IEEE Trans. Power Syst. 2005, Vol 20, No. 3, pp. 1496-1503.

2. Know the maximum available output of the intermittent generator at all times, and remain curtailed by a relatively constant amount below that level (unless raising or lowering generation in providing the load following service)
3. Accept instructions through an Automatic Generation Control (AGC) system
4. Adjust output continuously (minute to minute) in response to AGC signals

If these aspects can be feasibly achieved by an intermittent generator without a prohibitively large capital investment, then provision of load following services by that intermittent generator is likely to be technically feasible.

It has been shown that fuzzy logic control of the wind turbine pitch angle and generator torque can be used to create a constant power reserve. This power reserve can be used to provide active power to stabilise the grid in the event of a contingency⁸³. Other studies similarly illustrate the technical feasibility of wind farms contributing to frequency control^{84 85 86 87 88}.

16.2.2) Cost analysis

Secondly, it must be considered whether it is likely to be cost effective for intermittent generators to provide a load following service.

Based upon the analysis in section 14), the cost of ancillary services provided by Verve OCGT plant could range from \$6 /MWh to \$16 /MWh. By contrast, we assume that in order to provide one megawatt of load following service a wind farm would need to be curtailed by one megawatt, sacrificing revenue from the sale of wholesale electricity, and from the sale of renewable energy certificates (RECs).

It is expected that in any year RECs prices will be sufficient for the total revenue (from wholesale electricity and RECs) to be sufficient to cover the long run marginal costs of the most prevalent form of generation installed under the Renewable Energy Target (RET), which is likely to be wind technology. The long run marginal costs of most wind farms are currently of the order of \$120 /MWh. This means that an intermittent generator could be expected to be earning around \$120 /MWh for each megawatt hour sold.

⁸³ V. Courtecuisse, J. Sprooten, B. Robyns, J. Deuse. "Experiment of a wind generator participation to frequency control". EPE Journal, Vol. 18, no. 3, Sept 2008.

⁸⁴ J. Eek, K. Uhlen, T. Gjengedal, "Wind power contribution to primary frequency response in the Nordel power system", in proceedings of the third Nordic Wind Power Conference, May 2006.

⁸⁵ P. Bousseau, R. Belhomme, E. Monnot, N. Laverdure, D. Boeda, D. Roye, S. Bacha, "Contribution of wind farms to ancillary services", proceedings of CIGRE, Aug 2006, Paris, France.

⁸⁶ R. de Almeida, J. Lopes, "Participation of Doubly Fed Induction Wind Generators in System Frequency Regulation", IEEE Trans. Power Syst., Vol. 22, No. 3, 2007, pp. 944-950.

⁸⁷ P. Sorensen, A. Hansen, K. Thomsen, T. Buhl, P. Morthorsl, L. Nielsen, F. Iov, F. Blaabjerg, H. Nielsen, H. Madsen, M Donovan, "Operation and control of large wind turbines and wind farms", Riso National Laboratory Report, 2005.

⁸⁸ B. Khaki, M. Asgari, R. Sirjani, A. Mozdawar, "Contribution of DFIG wind turbines to system frequency control". IEEE, 2008.

By curtailing to provide one megawatt of load following service, an intermittent generator would therefore face an opportunity cost of \$120 /MWh, when the same service could be purchased from Verve at a cost of only \$6 /MWh to \$16 /MWh. This suggests that it is likely to be not cost effective for intermittent generators to provide a load following service.

While it is likely to be technically feasible, it is not likely to be cost effective for intermittent generators to provide a load following service (due to opportunity costs).

It has been similarly shown that for the provision of reactive power by wind farms, the opportunity cost is the largest component⁸⁹.

Some theoretical studies suggest that the non-uniform distribution of wind speed across a large wind farm can facilitate active power regulation with minimal reduction of total power generation⁹⁰. This suggests that a lower level of curtailment may be possible for a large wind farm to provide a load following service. These studies show promise, but must be proven experimentally and commercially before wide-scale implementation is possible.

Provision of load following service during curtailment

An exception to this occurs if an intermittent generator is already being curtailed for another reason (for example, if the minimum load is so low that the intermittent generator must be curtailed to allow sufficient load following plant to remain online). If an intermittent generator is already being curtailed by X MW, then that generator can offer X MW of load following service at no cost (since revenue has already been sacrificed). The intermittent generator can then avoid paying for Verve plant to provide the load following service at that time⁹¹.

In addition, since the intermittent generator is providing some load following service, less Verve plant is required to be dispatched for that service. If the intermittent generators in aggregate are curtailed by more than the total load following requirement, then they can provide the entire load following service at no cost, allowing Verve load following plant to be shut-down entirely. This allows more intermittent generation to be dispatched, through a reduction in the curtailment of the intermittent generator, and an increase in revenue from sales of electricity and RECs.

Under these conditions the total forecast output of the intermittent generators would need to be observed closely in case their output is likely to reduce substantially, requiring Verve load following plant to be brought back online.

⁸⁹ N. Ullah, K. Bahttacharya, T. Thiringer. "Wind farms as reactive power ancillary service providers - Technical and economic issues". IEEE Trans. Energy Convers., Vol. 24, No. 3, 2009.

⁹⁰ G. Tarnowski, R. Reginatto, "Adding active power regulation to wind farms with variable speed induction generators", IEEE 2007.

⁹¹ If curtailment of the wind farm is the result of network restrictions the wind farm would not be able to provide load following service, but would be able to regulate output to reduce variations and potentially avoid the need for additional load following plant to be operating (reducing costs).

This analysis indicates that this situation is likely to occur relatively rarely, and the capital investment involved in allowing an intermittent generator to provide a load following service may not be cost effective for those very rare circumstances. However, if minimum loads are lower than those used in this report, it may become of interest.

Figure 16.1 shows the percentage of the total wind farm capacity that would need to be curtailed to provide the whole load following service required. In early years wind farms would need to be curtailed by 35-40%; in later years they would only need to be curtailed by 15-20% of their total capacity.

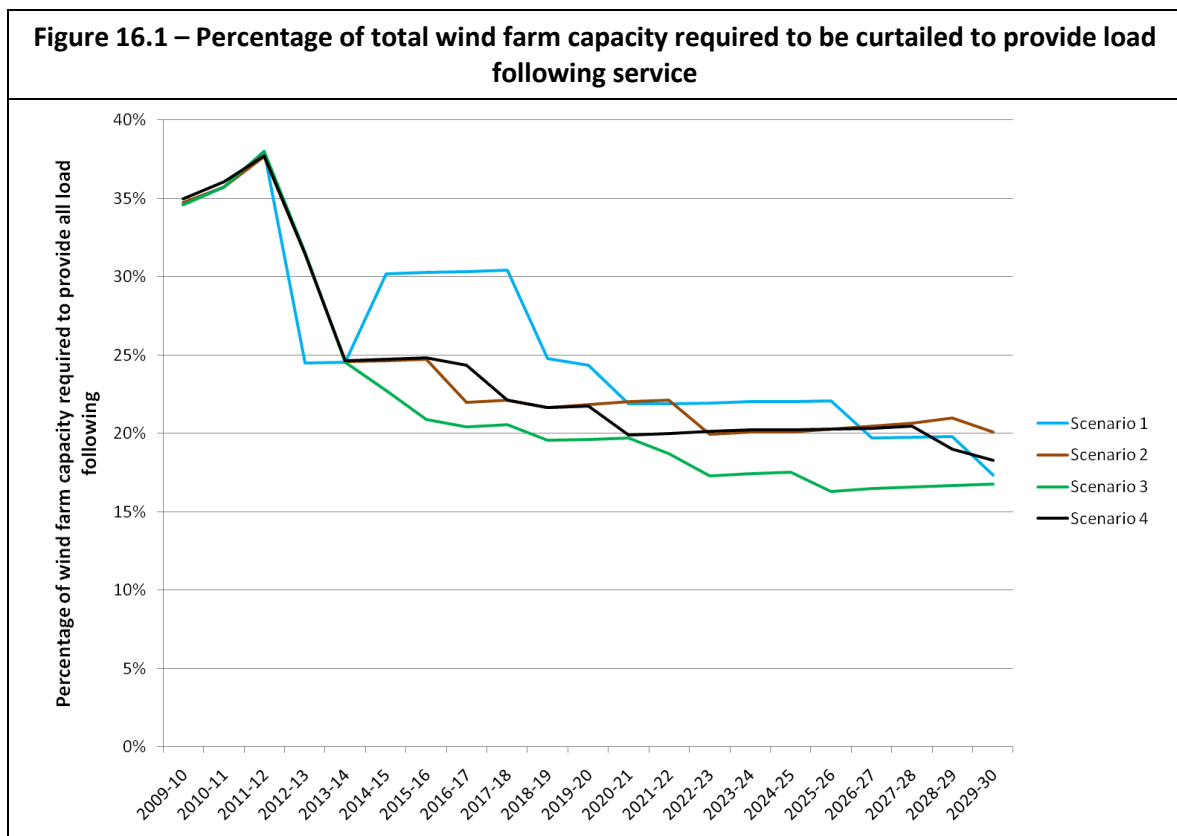

17) CONCLUSIONS AND RECOMMENDATIONS

Based upon the analysis conducted for this study, ROAM makes the following observations and conclusions:

The load following requirement increases substantially in response to penetration of intermittent generation (Section 7)

The load following requirement increases from the current value of 60 MW to 200-300 MW by 2030. The load following requirement is found to increase by 5-40% of the capacity of new installed wind farms, depending upon the location of the new wind farm (and its output

correlation with others previously installed). On average, 14% of the capacity of the new wind farm is added to the load following requirement.

Projected load following requirements can be technically provided under the existing rules and with existing infrastructure (Section 7.3)

To provide 300 MW of load following, Verve would need to dispatch 548 MW of OCGT plant on a continuous basis approximately half loaded. This can technically be provided by existing Verve plant. However, this is likely to be an inefficient and relatively expensive way to provide such a large quantity of load following service, and utilisation of opportunities to provide this service more efficiently are recommended.

Inertia and governor response are not limiting factors (Section 11.3)

This study suggests that if the existing definition for load following is used to allocate load following plant, the system frequency can be maintained to a sufficient level through the governor response of those units. This suggests that the existing methodology in use by System Management for maintaining system frequency is sufficient, and is likely to remain sufficient. In almost all cases no additional governor response is required, and system inertia does not become an issue. If additional fast response service is required, it is most effectively provided through an increased governor response (rather than through increasing system inertia). This could be provided with relative ease by tuning the governors of a wider range of plant.

The existing load following definition is sufficient (Section 5)

The current methodology for calculating the load following requirement does not account for "slow following" requirements (large, slow, coarse grained response load following), and "fast response" requirements (frequency control within one minute). ROAM developed metrics to account for these components, which were used to determine if they would become a problem in the event of high wind penetration (section 5). This report shows that these additional metrics are not likely to become an issue in the event of high wind penetration (section 7.2), and the existing definition of the load following service is likely to remain sufficient (section 11.3).

Equations in the Rules for determination of costs of load following are flawed (Section 14)

The equations defined in the existing WEM rules for the determination of the costs of the load following service are flawed. They do not allow for the situation where the load following requirement exceeds the spinning reserve requirement, which is likely to occur in the next few years. They also do not correctly account for load following services provided by contract (from providers other than Verve).

The cost of load following increases as wind levels increase (Section 14.8)

With the levels of wind penetration studied in this report (1000 MW by 2020 and 1700 MW by 2030) the costs of providing the load following service calculated using the existing methodology increase from current levels. With high wind penetration the total cost of load following increases from:

- \$10 million in 2008-09 to
- \$50-65 million by 2014-15,
- \$55-75 million by 2020 and

- \$65-90 million by 2030.

These projected costs equate to a 5 to 6 fold increase in total load following costs by 2014-15, and a 6 to 9 fold increase in total load following costs by 2030 (assuming that the existing rules continue to be applied). These costs are based upon the assumption that existing Rules and market conditions continue; costs could be much higher under alternative assumptions (for example, with higher gas prices, or a carbon price, as explored in section 14.9).

Costs increase rapidly in early years because the load following requirement increases rapidly as more wind is introduced. At higher levels of wind penetration the variability increases less (due to aggregation and geographical distribution of wind farms), so costs increase less dramatically in the later years of the study.

Cost calculations are very sensitive to changes in assumptions (Section 14.9) (Section 14.8.2)

If intermittent generators are responsible for the marginal cost of load following, they experience annual costs of \$20,000 - 55,000 per MW of installed wind capacity (based upon the assumption that existing market conditions continue). At a 40% capacity factor this equates to \$6-16 /MWh. Although this is a substantial cost, installation of wind in the SWIS could remain competitive with areas in the NEM due to the excellent wind resource available (40% capacity factor compared with 30% in South Australia, for example).

However, costs are found to be highly dependent on a wide range of assumptions, including the gas price and the presence (or absence) of an emissions trading scheme. Depending upon the assumptions used, costs could be much higher than those calculated based on the assumption that the existing Rules and market conditions continue (as used in section 14.8). Costs could be higher than \$300 million per annum by 2030, equating to \$50-\$60 /MWh in ancillary services costs for intermittent generators. This highlights the importance of various highly uncertain input assumptions in cost projections.

The division of cost between load following and spinning reserve needs review (section 14.9)

This analysis suggests that the existing methodology in the Rules for allocating availability costs between load following and spinning reserve is inaccurate. Although Verve can recover the same quantity of revenue regardless of the cost distribution, different market participants are responsible for the costs of load following and spinning reserve. This means that the relative proportions of the costs of these services is important.

Intermittent generators should pay the marginal cost of load following (Section 14.10)

60-80% of the load following requirement is projected to be due to intermittent generation, but if intermittent generators were required to pay this proportion of the load following cost, system loads would obtain a "wind-fall" gain through wind generation assuming their costs. Since load variability must be managed via a load following service as an inherent part of operating the system, intermittent generators should only be responsible for the costs of load following services in excess of this amount. This makes intermittent generators responsible for 50-60% of the costs of load following.

Dispatch priorities at time of minimum load will become important (Section 12)

In the most extreme scenario, by 2020-21 the installed wind capacity plus cogeneration and ancillary services capacity exceeds the annual minimum load. In the exceedingly rare circumstance that all installed wind farms were operating close to maximum capacity at the time of minimum load, this would mean that one or both of the following would need to occur to manage the system:

- Some (or all) wind farms would need to be curtailed
- Some (or all) large thermal plants would need to be shut down.

Importantly, the load is only forecast to be this low on one evening of the year. All other overnight troughs will have higher loads. In addition, due to geographical diversity of wind farms it will be a rare event to approach 100% output of all wind farms simultaneously. It is even more exceedingly unlikely that this event will occur at time of minimum load. Finally, this is the case only in the most extreme scenario (other scenarios have significantly lower quantities of installed wind). However, these results do suggest the increasing importance of transparent cost-based dispatch order priorities, particularly around overnight troughs. This should be addressed as a priority.

Facilities for wind curtailment are likely to be necessary (Section 12)

With high quantities of wind installed it is likely to become important that system management has the ability to curtail wind farms if necessary to manage the system.

Ramping limits on intermittent generators are ineffective at reducing variability (Section 15)

There is currently a requirement in the technical rules for the SWIS that non-scheduled generators do not increase or decrease their active power generation at a rate greater than 15% of the generator machine's nameplate rating per minute. This was found to be completely ineffective at reducing the load following requirement. To produce a significant reduction in the load following requirement it was necessary to reduce this ramp limit to 0.2% of the capacity of the wind farm. At this level, wind farms were curtailing 20% of their energy, which is clearly an inefficient result.

Intermittent generation is unlikely to be an attractive provider of load following service (Section 16)

While intermittent generators may have the technical ability to provide load following services, this would involve curtailing output by the amount of the load following requirement (20-30% of total capacity below available output). This involves sacrificing the substantial revenue available from the sale of electricity and Renewable Energy Certificates, and is unlikely to be competitive with the costs of ancillary services provided by Verve (or other thermal generation). Intermittent generators may be incentivised to provide load following services only if they are regularly curtailed by a large amount, in which case they can provide the load following service without sacrificing revenue, and possibly increase output if other load following plant can be taken offline.

Wind exhibits correlation within three distinct zones in the SWIS (Section 6.1.2)

Analysis conducted for this study indicates that wind generator output is likely to be correlated within three distinct zones: North coast (Geraldton and surrounds), around Perth, and South coast (Albany and surrounds). Distributing wind generation evenly across these zones will yield the most moderate outcome for load following requirements. Locating a new wind farm in an area that is uncorrelated with existing wind farms is shown to increase the load following requirement

by only 5% of the capacity of the wind farm. However, locating a new wind farm in an area that is highly correlated with existing wind farms can increase the load following requirement by 40% of the capacity of the wind farm.

17.1) RECOMMENDATIONS

Based upon the analysis in this report, ROAM makes the following recommendations:

Introduce an efficient, competitive market for the provision of ancillary services

By introducing an effective market for the provision of ancillary services, load following can be provided by the plant which can do so most efficiently. A co-optimised energy and reserve market similar to that in the NEM is suggested for further investigation. The establishment of an efficient market for load following and spinning reserve services would also avoid determining the costs of providing these services via arbitrary equations with the need for constant revision of calibration factors.

Arduous requirements for wind farms to provide system inertia should not be applied

The methodology in the Rules for the determination of the costs of load following and spinning reserve should be updated as a priority (suggested equations proposed in section 14.3).

The existing equations (clause 9.9.2 of the WEM Rules) are likely to become inadequate within the next few years. Alternative equations are proposed in the body of this report that address these immediate issues (section 14.4). Clauses 3.13.3, 3.13.3A and 3.22.1 are also affected (proposed revised texts are provided in section 14.4).

Actively seek opportunities to minimise load following costs.

Opportunities for minimising costs could include:

- Implementing a competitive market for ancillary services, allowing utilisation of the most efficient plant for provision of load following
- Implement market design changes to incentivise the commercial entry of technologies that can most cost effectively meet load following requirements
- Utilising plant other than OCGT plant for load following
- Utilising plant other than Verve plant for load following
- Investigating new technologies specifically designed for load following service (for example, the LMS100 units dramatically reduce load following costs)
- Investigating opportunities to minimise load following requirements, such as through
 - Effective wind forecasting
 - Allowing expanded frequency limits
 - More nuanced management of aggregate intermittent generation

ROAM recommends commissioning analysis to determine the relative effectiveness of these and other methods for reducing load following costs.

Review the methodology in the Rules for allocating the costs of spinning reserve and load following

Due to the different nature of the spinning reserve and load following services it is strongly recommended that a review of their relative costing in the Rules is undertaken. This can be achieved by modelling calculating these costs independently (rather than in aggregate). ROAM has proposed a detailed methodology and updated clause 9.9.2 incorporating changes that would address this issue. Over the longer term, the division of these costs could be most effectively achieved through the implementation of a competitive market for frequency control ancillary services.

Intermittent generators should pay the marginal cost of the provision of the load following service, above that required for load variability

This will require revision of clause 3.14.1 in the WEM Rules (allocation of load following costs). An alternative proposed drafting of this clause is provided in the body of the report (section 14.10.1).

Implement transparent cost-based dispatch merit order priorities in the SWIS

The current dispatch merit order priorities in the SWIS are far from a free cost-based and transparent market. This is likely to become a significant issue in the near future, and should be addressed as a priority. Market design changes should be investigated to provide a technically feasible least-cost outcome.

Intermittent generators must be able to curtail if necessary

It is important that sufficient installed intermittent generation of consequence has the facilities to curtail output if required (as is required by the existing Market Rules).

Ramp limits should not be applied to intermittent generators individually.

It may be effective to control aggregate ramping of intermittent generation, but this would be best achieved on a case-by-case basis by System Management as required. System Management has indicated that in their observations, whilst major ramp ups can occur across the wind farm fleet they are reasonably rare, normally occurring when major weather patterns (such as fronts) cross the coast.

Facilitating intermittent generators to provide load following services should not be an immediate priority.

Consider commissioning a detailed wind correlation study

It is important that wind farm developers have access to information relevant to their locational decisions. However, there is currently very little information available on wind correlation around the SWIS and its impacts on ancillary service requirements. Combined with appropriate incentives (such as intermittent generators being responsible for the correct proportion of the costs of ancillary services), this information could drive better wind locational decisions for the SWIS to minimise load following requirements. This study will also facilitate understanding the

degree of curtailment and the incidence of curtailment of wind production needed to implement other recommendations (in particular those associated with section 12)⁹².

⁹² Commissioning a study of this nature would necessitate sharing of hub height wind data at a one minute resolution, which has previously proved problematic.

Appendix A) LIST OF STATIONS IN THE SWIS

The properties of the existing stations in the SWIS used for this study are listed in Table A.1.

Table A.1 – Existing stations in the SWIS					
Plant Code	Plant name	Type	Participant name	Capacity (MW)	
				Minimum	Maximum
ALCOA_WGP	Alcoa Wagerup	Cogen	Alcoa of Australia Ltd T/A Alcoa World Alumina	20	25
ALINTA_PNJ_U1	Alinta Pinjarra U1	Cogen	Alinta Sales Pty Ltd	90	145
ALINTA_PNJ_U2	Alinta Pinjarra U2	Cogen	Alinta Sales Pty Ltd	90	145
PPP_KCP_EG1	Kwinana Cogen project (PPP_KCP_EG1)	Cogen	Verve Energy	53.2	79.2
SWCJV_WORSLEY_COGE_N_COG1	Worsley Cogen / SWCJV / Joint Venture	Cogen	Verve Energy	95	119
TIWEST_COG1	Tiwest cogen	Cogen	Verve Energy	14	37.7
ALINTA_WWF	Alinta wind farm (Walkaway)	Wind	Alinta Sales Pty Ltd	0	89.1
ALBANY_WF1	Albany	Wind	Verve Energy	0	21.6
Emu Downs	Emu Downs	Wind	EDWF Manager Pty Ltd	0	80
BW1_BLUEWATERS_G2	Bluewaters U1 G2	Coal	Griffin Power Pty Ltd	100	208
BW1_BLUEWATERS_G2	Bluewaters U2 G2	Coal	Griffin Power Pty Ltd	100	208
COLLIE_G1	Collie A G1	Coal	Verve Energy	160	315
MUJA_G7	Muja D G7	Coal	Verve Energy	70	211
MUJA_G8	Muja D G8	Coal	Verve Energy	70	211
MUJA_G5	Muja C G5	Coal	Verve Energy	65	185
MUJA_G6	Muja C G6	Coal	Verve Energy	65	185
COCKBURN_CCG1	Cockburn CCG1	CCGT	Verve Energy	165	236.6
KWINANA_G1	Kwinana Power Station A G1	Coal	Verve Energy	45	111.5
KWINANA_G2	Kwinana Power Station A G2	Coal	Verve Energy	45	111.5
KWINANA_G5	Kwinana Power Station C G5	Coal	Verve Energy	50	177
KWINANA_G6	Kwinana Power Station C G6	Coal	Verve Energy	50	177
NEWGEN_KWINANA_CC_G1	NewGen Kwinana CCG1	CCGT	NewGen Power Kwinana Pty Ltd	160	324
ALINTA_WGP_GT	Alinta Wagerup GT	OCGT	Alinta Sales Pty Ltd	114	190
ALINTA_WGP_U2	Alinta Wagerup U2	OCGT	Alinta Sales Pty Ltd	114	190
PRK_AG	Parkeston	OCGT	Goldfields Power Pty Ltd	0	68
STHRNCRS_EG	Southern Cross EG	OCGT	Southern Cross Energy	0	23
KWINANA_GT1	Kwinana GT1	OCGT	Verve Energy	6	20.8
PINJAR_GT11	Pinjar GT11	OCGT	Verve Energy	35	123
PINJAR_GT10	Pinjar GT10	OCGT	Verve Energy	35	116

Table A.1 – Existing stations in the SWIS

Plant Code	Plant name	Type	Participant name	Capacity (MW)	
				Minimum	Maximum
PINJAR_GT9	Pinjar GT9	OCGT	Verve Energy	35	116
KEMERTON_GT11	Kemerton GT11	OCGT	Verve Energy	80	154
KEMERTON_GT12	Kemerton GT12	OCGT	Verve Energy	80	154
PINJAR_GT1	Pinjar GT1	OCGT	Verve Energy	10	37.2
PINJAR_GT2	Pinjar GT2	OCGT	Verve Energy	10	37.2
PINJAR_GT3	Pinjar GT3	OCGT	Verve Energy	10	38.2
PINJAR_GT4	Pinjar GT4	OCGT	Verve Energy	10	38.2
PINJAR_GT5	Pinjar GT5	OCGT	Verve Energy	10	38.2
PINJAR_GT7	PinjarGT7	OCGT	Verve Energy	10	38.2
MUNGARRA_GT1	Mungarra GT1	CCGT	Verve Energy	10	37.2
MUNGARRA_GT2	Mungarra GT2	CCGT	Verve Energy	10	37.2
MUNGARRA_GT3	Mungarra GT3	CCGT	Verve Energy	10	38.2
WEST_KALGOORLIE_GT2	West Kalgoorlie GT2	OCGT	Verve Energy	10	38.2
WEST_KALGOORLIE_GT3	West Kalgoorlie GT3	OCGT	Verve Energy	6	24.6
GERALDTON_GT1	Geraldton GT1	OCGT	Verve Energy	6	20.8

The properties of new stations in the SWIS used for this study are listed in Table A.2. Planting schedules assumed for the timetable of development of these new stations are listed in the following appendix.

Table A.2 – New stations for development in the SWIS

Plant name	Type	Capacity (MW)		Participant
		Minimum	Maximum	
Energy Response DSM1	DSM	23	0	IPP
Energy Response DSM2	DSM	73	0	IPP
DSM1	DSM	200	0	IPP
DSM2	DSM	200	0	IPP
Bluewaters 3	Coal	215	107.5	IPP
Bluewaters 4	Coal	215	107.5	IPP
Coolimba Aviva Coal	Coal	400	200	IPP
Muja AB	Coal	220	110	IPP
Kwinana CCGT 1	CCGT	100	50	IPP
Kwinana CCGT 2	CCGT	100	50	IPP
Kwinana HEGT	CCGT	194	97	IPP
North Country CCGT 1	CCGT	125	62.5	IPP
North Country CCGT 2	CCGT	125	62.5	IPP
North Country CCGT 3	CCGT	125	62.5	IPP
North Metro CCGT 1	CCGT	110	55	IPP

Table A.2 – New stations for development in the SWIS

Plant name	Type	Capacity (MW)		Participant
		Minimum	Maximum	
North Metro CCGT 2	CCGT	110	55	IPP
North Metro CCGT 3	CCGT	110	55	IPP
North Metro CCGT 4	CCGT	110	55	IPP
Northern Terminal CCGT 1	CCGT	110	55	IPP
Northern Terminal CCGT 2	CCGT	110	55	IPP
Northern Terminal CCGT 3	CCGT	110	55	IPP
Kwinana OCGT 1	OCGT	100	27	IPP
Kwinana OCGT 2	OCGT	100	27	IPP
Kwinana OCGT 3	OCGT	100	27	IPP
Muja OCGT 1	OCGT	58	15.66	IPP
Muja OCGT 2	OCGT	58	15.66	IPP
Namarkkon	OCGT	74	19.98	IPP
North Country OCGT 1	OCGT	125	33.75	IPP
North Country OCGT 2	OCGT	125	33.75	IPP
North Metro OCGT 1	OCGT	110	29.7	IPP
North Metro OCGT 2	OCGT	110	29.7	IPP
North Metro OCGT 3	OCGT	110	29.7	IPP
Northern Terminal OCGT 1	OCGT	110	29.7	IPP
Northern Terminal OCGT 2	OCGT	110	29.7	IPP
Northern Terminal OCGT 3	OCGT	110	29.7	IPP
Joanna Plains Peaking	Diesel	106	28.62	IPP
Muja Diesel 1	Diesel	30	8.1	IPP
Muja Diesel 3	Diesel	30	8.1	IPP
Muja Diesel 4	Diesel	30	8.1	IPP
Tesla Diesel Units 1-2	Diesel	20	5.4	IPP
Tesla Diesel Units 3-8	Diesel	60	16.2	IPP
Tesla Diesel Units 9-15	Diesel	66	17.82	IPP
Wild Energy	Diesel	10	2.673	IPP
Alinta Walkaway 2	Wind	94	0	IPP
Badgingarra	Wind	130	0	IPP
Collgar	Wind	250	0	IPP
East Country Wind 1	Wind	250	0	IPP
Grasmere	Wind	14	0	IPP
Milyeannup	Wind	55	0	IPP
Muja Wind 1	Wind	215	0	IPP
Muja Wind 2	Wind	215	0	IPP
Nilgen	Wind	132	0	IPP

Table A.2 – New stations for development in the SWIS

Plant name	Type	Capacity (MW)		Participant
		Minimum	Maximum	
North Country Wind 1	Wind	200	0	IPP
North Country Wind 2	Wind	200	0	IPP
Spiritwest Neerabup	Biomass	30	14.95	IPP
WA Biomass	Biomass	40	20	IPP
Kalgoorlie PV	Solar PV	30	0	IPP
Mingenew Solar Thermal 1	Solar Thermal	50	0	IPP
Mingenew Solar Thermal 2	Solar Thermal	50	0	IPP
Mingenew Solar Thermal 3	Solar Thermal	100	0	IPP
Carnegie Wave 1	Wave	5	0	IPP
Carnegie Wave 2	Wave	20	0	IPP
Carnegie Wave 3	Wave	50	0	IPP
Carnegie Wave 4	Wave	100	0	IPP
EGS Geothermal 1	Geo	10	5	IPP
EGS Geothermal 2	Geo	50	25	IPP
EGS Geothermal 3	Geo	50	25	IPP
EGS Geothermal 4	Geo	50	25	IPP
HSA Geothermal 1	Geo	30	15	IPP
Newworld Geothermal 1	Geo	5	2.5	IPP
Newworld Geothermal 2	Geo	10	5	IPP
Newworld Geothermal 3	Geo	15	7.5	IPP
CCS Pilot 1	CCS	100	50	IPP
Coolimba Aviva Coal CCS	CCS	400	200	IPP
Kwinana B - LMS100 U1	OCGT	100	27	IPP
Kwinana B - LMS100 U2	OCGT	100	27	IPP

Appendix B) PLANTING SCHEDULES FOR SCENARIOS

The following tables show the planting schedules developed for each scenario.

Table B.1 – Scenario 1 Planting Schedule				
Year	Capacity (MW)	Plant	Type	Location
2010-11	23MW	Energy Response DSM1	DSM	SWIS
2010-11	-240MW	Kwinana A Retirement	Gas	Kwinana
2011-12	73MW	Energy Response DSM2	DSM	SWIS
2012-13	194MW	Kwinana HEGT	CCGT	Kwinana
2012-13	130MW	Badgingarra	Wind	North Country
2012-13	106MW	Joanna Plains Peaking	Diesel	North Country
2012-13	250MW	Collgar	Wind	East Country
2012-13	5MW	Carnegie Wave 1	Wave	Kwinana
2013-14	215MW	Bluewaters 3	Coal	Muja
2013-14	125MW	North Country OCGT 1	OCGT	North Country
2014-15	250MW	East Country Wind 1	Wind	East Country
2015-16	215MW	Bluewaters 4	Coal	Muja
2016-17	30MW	Spiritwest Neerabup	Biomass	North Metro
2016-17	20MW	Tesla Diesel Units 1-2	Diesel	SWIS
2016-17	58MW	Muja OCGT 1	OCGT	Muja
2016-17	110MW	North Metro CCGT 1	CCGT	North Metro
2017-18	125MW	North Country OCGT 2	OCGT	North Country
2018-19	200MW	North Country Wind 1	Wind	North Country
2018-19	110MW	Northern Terminal CCGT 1	CCGT	Northern Terminal
2019-20	74MW	Namarkkon	OCGT	East Country
2019-20	30MW	Muja Diesel 1	Diesel	Muja
2019-20	110MW	Northern Terminal CCGT 2	CCGT	Northern Terminal
2019-20	20MW	Carnegie Wave 2	Wave	Kwinana
2020-21	50MW	Mingenew Solar Thermal 1	Solar Thermal	North Country
2020-21	215MW	Muja Wind 1	Wind	Muja
2020-21	30MW	Muja Diesel 2	Diesel	Muja
2020-21	100MW	Kwinana CCGT 1	CCGT	Kwinana
2020-21	100MW	Kwinana OCGT 1	OCGT	Kwinana
2020-21	58MW	Muja OCGT 2	OCGT	Muja
2020-21	-370MW	Muja C Retirement	Coal	Muja
2021-22	200MW	DSM1	DSM	SWIS
2022-23	125MW	North Country CCGT 1	CCGT	North Country

Table B.1 – Scenario 1 Planting Schedule

Year	Capacity (MW)	Plant	Type	Location
2022-23	30MW	HSA Geothermal 1	Geo	North Country
2023-24	100MW	Kwinana OCGT 2	OCGT	Kwinana
2023-24	110MW	North Metro OCGT 1	OCGT	North Metro
2023-24	10MW	EGS Geothermal 1	Geo	North Country
2024-25	100MW	Kwinana CCGT 2	CCGT	Kwinana
2025-26	125MW	North Country CCGT 2	CCGT	North Country
2025-26	110MW	North Metro OCGT 2	OCGT	North Metro
2025-26	110MW	North Metro CCGT 2	CCGT	North Metro
2025-26	110MW	Northern Terminal OCGT 1	OCGT	Northern Terminal
2025-26	110MW	Northern Terminal CCGT 3	CCGT	Northern Terminal
2025-26	-422MW	Muja D Retirement	Coal	Muja
2026-27	200MW	North Country Wind 2	Wind	North Country
2026-27	110MW	North Metro OCGT 3	OCGT	North Metro
2026-27	110MW	Northern Terminal OCGT 2	OCGT	Northern Terminal
2027-28	110MW	Northern Terminal OCGT 3	OCGT	Northern Terminal
2028-29	125MW	North Country CCGT 3	CCGT	North Country
2028-29	100MW	Kwinana OCGT 3	OCGT	Kwinana
2029-30	215MW	Muja Wind 2	Wind	Muja
2029-30	50MW	Carnegie Wave 3	Wave	Muja

Table B.2 – Scenario 2 - Planting Schedule

Year	Capacity (MW)	Plant	Type	Location
2010-11	23MW	Energy Response DSM1	DSM	SWIS
2010-11	-240MW	Kwinana A Retirement	Gas	Kwinana
2011-12	106MW	Joanna Plains Peaking	Diesel	North Country
2011-12	73MW	Energy Response DSM2	DSM	SWIS
2012-13	194MW	Kwinana HEGT	CCGT	Kwinana
2012-13	130MW	Badgingarra	Wind	North Country
2012-13	5MW	Carnegie Wave 1	Wave	Kwinana
2013-14	220MW	Muja AB	Coal	Muja
2013-14	74MW	Namarkkon	OCGT	East Country
2013-14	250MW	Collgar	Wind	East Country
2014-15	100MW	Kwinana OCGT 1	OCGT	Kwinana
2015-16	40MW	WA Biomass	Biomass	Muja
2015-16	125MW	North Country CCGT 1	CCGT	North Country

Table B.2 – Scenario 2 - Planting Schedule

Year	Capacity (MW)	Plant	Type	Location
2015-16	125MW	North Country OCGT 1	OCGT	North Country
2016-17	14MW	Grasmere	Wind	Muja
2016-17	94MW	Alinta Walkaway 2	Wind	North Country
2016-17	100MW	Kwinana CCGT 1	CCGT	Kwinana
2016-17	58MW	Muja OCGT 1	OCGT	Muja
2017-18	20MW	Tesla Diesel Units 1-2	Diesel	SWIS
2017-18	58MW	Muja OCGT 2	OCGT	Muja
2017-18	110MW	Northern Terminal OCGT 1	OCGT	Northern Terminal
2018-19	30MW	Muja Diesel 1	Diesel	Muja
2018-19	30MW	Muja Diesel 2	Diesel	Muja
2018-19	110MW	North Metro OCGT 1	OCGT	North Metro
2018-19	20MW	Carnegie Wave 2	Wave	Kwinana
2019-20	30MW	Spiritwest Neerabup	Biomass	North Metro
2019-20	125MW	North Country OCGT 2	OCGT	North Country
2020-21	5MW	Newworld Geothermal 1	Geo	North Country
2020-21	110MW	North Metro CCGT 1	CCGT	North Metro
2021-22	60MW	Tesla Diesel Units 3-8	Diesel	SWIS
2021-22	30MW	Kalgoorlie PV	Solar PV	East Country
2021-22	10MW	Newworld Geothermal 2	Geo	North Country
2021-22	110MW	Northern Terminal CCGT 1	CCGT	Northern Terminal
2022-23	132MW	Nilgen	Wind	North Country
2022-23	100MW	Kwinana OCGT 2	OCGT	Kwinana
2022-23	30MW	HSA Geothermal 1	Geo	North Country
2023-24	215MW	Bluewaters 3	Coal	Muja
2024-25	50MW	Mingenew Solar Thermal 1	Solar Thermal	North Country
2024-25	110MW	North Metro CCGT 2	CCGT	North Metro
2025-26	66MW	Tesla Diesel Units 9-15	Diesel	SWIS
2025-26	200MW	DSM1	DSM	SWIS
2025-26	110MW	North Metro OCGT 2	OCGT	North Metro
2025-26	110MW	North Metro OCGT 3	OCGT	North Metro
2025-26	10MW	EGS Geothermal 1	Geo	North Country
2025-26	110MW	Northern Terminal CCGT 3	CCGT	Northern Terminal
2025-26	-370MW	Muja C Retirement	Coal	Muja
2026-27	15MW	Newworld Geothermal 3	Geo	North Country
2026-27	125MW	North Country CCGT 2	CCGT	North Country
2027-28	100MW	Kwinana CCGT 2	CCGT	Kwinana
2027-28	110MW	Northern Terminal CCGT 2	CCGT	Northern Terminal

Table B.2 – Scenario 2 - Planting Schedule

Year	Capacity (MW)	Plant	Type	Location
2028-29	200MW	North Country Wind 1	Wind	North Country
2028-29	110MW	North Metro CCGT 3	CCGT	North Metro
2029-30	50MW	Mingenew Solar Thermal 2	Solar Thermal	North Country
2029-30	30MW	Muja Diesel 3	Diesel	Muja
2029-30	30MW	Muja Diesel 4	Diesel	Muja
2029-30	50MW	Carnegie Wave 3	Wave	Muja

Table B.3 – Scenario 3 - Planting Schedule

Year	Capacity (MW)	Plant	Type	Location
2010-11	23MW	Energy Response DSM1	DSM	SWIS
2010-11	-240MW	Kwinana A Retirement	Gas	Kwinana
2011-12	73MW	Energy Response DSM2	DSM	SWIS
2012-13	194MW	Kwinana HEGT	CCGT	Kwinana
2012-13	130MW	Badgingarra	Wind	North Country
2012-13	106MW	Joanna Plains Peaking	Diesel	North Country
2012-13	5MW	Carnegie Wave 1	Wave	Kwinana
2013-14	250MW	Collgar	Wind	East Country
2013-14	125MW	North Country OCGT 1	OCGT	North Country
2013-14	110MW	North Metro CCGT 1	CCGT	North Metro
2014-15	55MW	Milyeannup	Wind	Muja
2014-15	5MW	Newworld Geothermal 1	Geo	North Country
2015-16	94MW	Alinta Walkaway 2	Wind	North Country
2015-16	200MW	DSM1	DSM	SWIS
2015-16	10MW	Newworld Geothermal 2	Geo	North Country
2016-17	74MW	Namarkkon	OCGT	East Country
2016-17	20MW	Tesla Diesel Units 1-2	Diesel	SWIS
2016-17	40MW	WA Biomass	Biomass	Muja
2016-17	58MW	Muja OCGT 1	OCGT	Muja
2016-17	125MW	North Country OCGT 2	OCGT	North Country
2016-17	110MW	Northern Terminal CCGT 1	CCGT	Northern Terminal
2016-17	110MW	Northern Terminal CCGT 2	CCGT	Northern Terminal
2016-17	20MW	Carnegie Wave 2	Wave	Kwinana
2016-17	-370MW	Muja C Retirement	Coal	Muja
2017-18	30MW	Spiritwest Neerabup	Biomass	North Metro
2017-18	200MW	DSM2	DSM	SWIS
2017-18	15MW	Newworld Geothermal 3	Geo	North Country

Table B.3 – Scenario 3 - Planting Schedule

Year	Capacity (MW)	Plant	Type	Location
2018-19	30MW	Kalgoorlie PV	Solar PV	East Country
2018-19	215MW	Muja Wind 1	Wind	Muja
2018-19	125MW	North Country CCGT 1	CCGT	North Country
2019-20	30MW	Muja Diesel 1	Diesel	Muja
2019-20	100MW	Kwinana OCGT 1	OCGT	Kwinana
2019-20	30MW	HSA Geothermal 1	Geo	North Country
2020-21	50MW	Mingenew Solar Thermal 1	Solar Thermal	North Country
2020-21	100MW	Kwinana CCGT 1	CCGT	Kwinana
2020-21	58MW	Muja OCGT 2	OCGT	Muja
2020-21	110MW	North Metro OCGT 2	OCGT	North Metro
2020-21	110MW	North Metro CCGT 2	CCGT	North Metro
2020-21	100MW	CCS Pilot 1	CCS	Muja
2020-21	-422MW	Muja D Retirement	Coal	Muja
2021-22	125MW	North Country CCGT 2	CCGT	North Country
2021-22	50MW	Carnegie Wave 3	Wave	Muja
2022-23	132MW	Nilgen	Wind	North Country
2022-23	110MW	North Metro OCGT 1	OCGT	North Metro
2022-23	10MW	EGS Geothermal 1	Geo	North Country
2023-24	400MW	Coolimba Aviva Coal CCS	CCS	North Country
2025-26	50MW	Mingenew Solar Thermal 2	Solar Thermal	North Country
2025-26	100MW	Kwinana OCGT 2	OCGT	Kwinana
2025-26	110MW	North Metro CCGT 3	CCGT	North Metro
2025-26	100MW	Carnegie Wave 4	Wave	North Country
2025-26	50MW	EGS Geothermal 2	Geo	North Country
2025-26	-350MW	Kwinana C Retirement	Coal	Kwinana
2026-27	100MW	Kwinana CCGT 2	CCGT	Kwinana
2026-27	110MW	Northern Terminal OCGT 1	OCGT	Northern Terminal
2027-28	200MW	North Country Wind 1	Wind	North Country
2027-28	125MW	North Country CCGT 3	CCGT	North Country
2028-29	110MW	North Metro CCGT 4	CCGT	North Metro
2028-29	100MW	Kwinana OCGT 3	OCGT	Kwinana
2029-30	50MW	EGS Geothermal 3	Geo	North Country
2029-30	50MW	EGS Geothermal 4	Geo	Muja

Table B.4 – Scenario 4 - Planting Schedule

Year	Capacity (MW)	Plant	Type	Location
2010-11	23MW	Energy Response DSM1	DSM	SWIS
2010-11	-240MW	Kwinana A Retirement	Gas	Kwinana
2011-12	106MW	Joanna Plains Peaking	Diesel	North Country
2011-12	73MW	Energy Response DSM2	DSM	SWIS
2012-13	220MW	Muja AB	Coal	Muja
2012-13	194MW	Kwinana HEGT	CCGT	Kwinana
2012-13	130MW	Badgingarra	Wind	North Country
2012-13	5MW	Carnegie Wave 1	Wave	Kwinana
2013-14	74MW	Namarkkon	OCGT	East Country
2013-14	250MW	Collgar	Wind	East Country
2013-14	100MW	Kwinana OCGT 1	OCGT	Kwinana
2013-14	125MW	North Country OCGT 1	OCGT	North Country
2014-15	125MW	North Country OCGT 2	OCGT	North Country
2015-16	400MW	Coolimba Aviva Coal	Coal	North Country
2016-17	14MW	Grasmere	Wind	Muja
2016-17	58MW	Muja OCGT 1	OCGT	Muja
2017-18	10MW	Wild Energy	Diesel	Muja
2017-18	40MW	WA Biomass	Biomass	Muja
2017-18	94MW	Alinta Walkaway 2	Wind	North Country
2017-18	58MW	Muja OCGT 2	OCGT	Muja
2017-18	110MW	Northern Terminal OCGT 1	OCGT	Northern Terminal
2018-19	20MW	Tesla Diesel Units 1-2	Diesel	SWIS
2018-19	30MW	Muja Diesel 1	Diesel	Muja
2018-19	30MW	Muja Diesel 2	Diesel	Muja
2018-19	110MW	North Metro OCGT 1	OCGT	North Metro
2018-19	20MW	Carnegie Wave 2	Wave	Kwinana
2019-20	215MW	Bluewaters 3	Coal	Muja
2020-21	30MW	Spiritwest Neerabup	Biomass	North Metro
2020-21	132MW	Nilgen	Wind	North Country
2020-21	5MW	Newworld Geothermal 1	Geo	North Country
2020-21	100MW	Kwinana OCGT 2	OCGT	Kwinana
2021-22	30MW	Kalgoorlie PV	Solar PV	East Country
2021-22	100MW	Kwinana CCGT 1	CCGT	Kwinana
2021-22	125MW	North Country CCGT 1	CCGT	North Country
2022-23	60MW	Tesla Diesel Units 3-8	Diesel	SWIS
2022-23	10MW	Newworld Geothermal 2	Geo	North Country
2022-23	30MW	HSA Geothermal 1	Geo	North Country

Table B.4 – Scenario 4 - Planting Schedule

Year	Capacity (MW)	Plant	Type	Location
2022-23	110MW	Northern Terminal OCGT 3	OCGT	Northern Terminal
2023-24	215MW	Bluewaters 4	Coal	Muja
2024-25	50MW	Mingenew Solar Thermal 1	Solar Thermal	North Country
2024-25	100MW	CCS Pilot 1	CCS	Muja
2025-26	66MW	Tesla Diesel Units 9-15	Diesel	SWIS
2025-26	110MW	North Metro OCGT 2	OCGT	North Metro
2025-26	10MW	EGS Geothermal 1	Geo	North Country
2025-26	110MW	Northern Terminal OCGT 2	OCGT	Northern Terminal
2026-27	110MW	North Metro OCGT 3	OCGT	North Metro
2027-28	125MW	North Country CCGT 2	CCGT	North Country
2027-28	110MW	North Metro CCGT 2	CCGT	North Metro
2028-29	215MW	Muja Wind 1	Wind	Muja
2028-29	15MW	Newworld Geothermal 3	Geo	North Country
2028-29	100MW	Kwinana CCGT 2	CCGT	Kwinana
2028-29	100MW	Kwinana OCGT 3	OCGT	Kwinana
2029-30	50MW	Mingenew Solar Thermal 2	Solar Thermal	North Country
2029-30	30MW	Muja Diesel 3	Diesel	Muja
2029-30	50MW	Carnegie Wave 3	Wave	Muja
2029-30	50MW	EGS Geothermal 2	Geo	North Country

Appendix C) DISPATCH MERIT ORDER

The dispatch merit order assumed as a starting point for this analysis is shown in the table below.

Table C.1 – Dispatch Merit Order				
	Station name	Dispatch to:	Type	Participant
1	Plant required for load following			
2	ALCOA_WGP	min_load	Cogen	Alcoa of Australia Ltd T/A Alcoa World Alumina
3	ALINTA_PNJ_U1	min_load	Cogen	Alinta Sales Pty Ltd
4	ALINTA_PNJ_U2	min_load	Cogen	Alinta Sales Pty Ltd
5	PPP_KCP_EG1	min_load	Cogen	Verve Energy
6	SWCJV_WORSLEY_COGEN_COG1	min_load	Cogen	Verve Energy
7	TIWEST_COG1	min_load	Cogen	Verve Energy
8	Kalgoorlie PV	max_load	Solar PV	IPP
9	Mingenew Solar Thermal 1	max_load	Solar Thermal	IPP
10	Mingenew Solar Thermal 2	max_load	Solar Thermal	IPP
11	Mingenew Solar Thermal 3	max_load	Solar Thermal	IPP
12	Carnegie Wave 1	max_load	Wave	IPP
13	Carnegie Wave 2	max_load	Wave	IPP
14	Carnegie Wave 3	max_load	Wave	IPP
15	Carnegie Wave 4	max_load	Wave	IPP
16	Alinta Walkaway 2	max_load	Wind	IPP
17	Badgingarra	max_load	Wind	IPP
18	Collgar	max_load	Wind	IPP
19	East Country Wind 1	max_load	Wind	IPP
20	Grasmere	max_load	Wind	IPP
21	Milyeannup	max_load	Wind	IPP
22	Muja Wind 1	max_load	Wind	IPP
23	Muja Wind 2	max_load	Wind	IPP
24	Nilgen	max_load	Wind	IPP
25	North Country Wind 1	max_load	Wind	IPP
26	North Country Wind 2	max_load	Wind	IPP
27	ALINTA_WWF	max_load	Wind	Alinta Sales Pty Ltd
28	EMU_DOWNS	max_load	Wind	EDWF Manager Pty Ltd
29	ALBANY_WF1	max_load	Wind	Verve Energy
30	Spiritwest Neerabup	min_load	Biomass	IPP
31	WA Biomass	min_load	Biomass	IPP
32	Bluewaters 3	min_load	Coal	IPP
33	Bluewaters 4	min_load	Coal	IPP

Table C.1 – Dispatch Merit Order

	Station name	Dispatch to:	Type	Participant
34	Coolimba Aviva Coal	min_load	Coal	IPP
35	BW1_BLUEWATERS_G2	min_load	Coal	Griffin Power Pty Ltd
36	BW1_BLUEWATERS_G2	min_load	Coal	Griffin Power Pty Ltd
37	COLLIE_G1	min_load	Coal	Verve Energy
38	MUJA_G8	min_load	Coal	Verve Energy
39	MUJA_G7	min_load	Coal	Verve Energy
40	MUJA_G6	min_load	Coal	Verve Energy
41	MUJA_G5	min_load	Coal	Verve Energy
42	COCKBURN_CCG1	min_load	CCGT	Verve Energy
43	KWINANA_G5	min_load	Coal	Verve Energy
44	KWINANA_G6	min_load	Coal	Verve Energy
45	KWINANA_G1	min_load	Coal	Verve Energy
46	KWINANA_G2	min_load	Coal	Verve Energy
47	Muja AB	min_load	Coal	Verve Energy
48	EGS Geothermal 1	min_load	Geo	IPP
49	EGS Geothermal 2	min_load	Geo	IPP
50	EGS Geothermal 3	min_load	Geo	IPP
51	EGS Geothermal 4	min_load	Geo	IPP
52	HSA Geothermal 1	min_load	Geo	IPP
53	Newworld Geothermal 1	min_load	Geo	IPP
54	Newworld Geothermal 2	min_load	Geo	IPP
55	Newworld Geothermal 3	min_load	Geo	IPP
56	Kwinana CCGT 1	min_load	CCGT	IPP
57	Kwinana CCGT 2	min_load	CCGT	IPP
58	Kwinana HEGT	min_load	CCGT	IPP
59	North Country CCGT 1	min_load	CCGT	IPP
60	North Country CCGT 2	min_load	CCGT	IPP
61	North Country CCGT 3	min_load	CCGT	IPP
62	North Metro CCGT 1	min_load	CCGT	IPP
63	North Metro CCGT 2	min_load	CCGT	IPP
64	North Metro CCGT 3	min_load	CCGT	IPP
65	North Metro CCGT 4	min_load	CCGT	IPP
66	Northern Terminal CCGT 1	min_load	CCGT	IPP
67	Northern Terminal CCGT 2	min_load	CCGT	IPP
68	Northern Terminal CCGT 3	min_load	CCGT	IPP
69	NEWGEN_KWINANA_CCG1	min_load	CCGT	NewGen Power Kwinana Pty Ltd
70	ALCOA_WGP	max_load	Cogen	Alcoa of Australia Ltd T/A Alcoa World Alumina
71	ALINTA_PNJ_U1	max_load	Cogen	Alinta Sales Pty Ltd
72	ALINTA_PNJ_U2	max_load	Cogen	Alinta Sales Pty Ltd
73	PPP_KCP_EG1	max_load	Cogen	Verve Energy
74	SWCJV_WORSLEY_COGEN_	max_load	Cogen	Verve Energy

Table C.1 – Dispatch Merit Order

	Station name	Dispatch to:	Type	Participant
	COG1			
75	TIWEST_COG1	max_load	Cogen	Verve Energy
76	EGS Geothermal 1	max_load	Geo	IPP
77	EGS Geothermal 2	max_load	Geo	IPP
78	EGS Geothermal 3	max_load	Geo	IPP
79	EGS Geothermal 4	max_load	Geo	IPP
80	HSA Geothermal 1	max_load	Geo	IPP
81	Newworld Geothermal 1	max_load	Geo	IPP
82	Newworld Geothermal 2	max_load	Geo	IPP
83	Newworld Geothermal 3	max_load	Geo	IPP
84	Spiritwest Neerabup	max_load	Biomass	IPP
85	WA Biomass	max_load	Biomass	IPP
86	CCS Pilot 1	max_load	CCS	IPP
87	Coolimba Aviva Coal CCS	max_load	CCS	IPP
88	BW1_BLUEWATERS_G2	max_load	Coal	Griffin Power Pty Ltd
89	BW1_BLUEWATERS_G2	max_load	Coal	Griffin Power Pty Ltd
90	MUJA_G8	max_load	Coal	Verve Energy
91	MUJA_G7	max_load	Coal	Verve Energy
92	MUJA_G6	max_load	Coal	Verve Energy
93	MUJA_G5	max_load	Coal	Verve Energy
94	COLLIE_G1	max_load	Coal	Verve Energy
95	COCKBURN_CCG1	max_load	CCGT	Verve Energy
96	KWINANA_G1	max_load	Coal	Verve Energy
97	KWINANA_G2	max_load	Coal	Verve Energy
98	KWINANA_G5	max_load	Coal	Verve Energy
99	KWINANA_G6	max_load	Coal	Verve Energy
100	Kwinana CCGT 1	max_load	CCGT	IPP
101	Kwinana CCGT 2	max_load	CCGT	IPP
102	Kwinana HEGT	max_load	CCGT	IPP
103	North Country CCGT 1	max_load	CCGT	IPP
104	North Country CCGT 2	max_load	CCGT	IPP
105	North Country CCGT 3	max_load	CCGT	IPP
106	North Metro CCGT 1	max_load	CCGT	IPP
107	North Metro CCGT 2	max_load	CCGT	IPP
108	North Metro CCGT 3	max_load	CCGT	IPP
109	North Metro CCGT 4	max_load	CCGT	IPP
110	Northern Terminal CCGT 1	max_load	CCGT	IPP
111	Northern Terminal CCGT 2	max_load	CCGT	IPP
112	Northern Terminal CCGT 3	max_load	CCGT	IPP
113	NEWGEN_KWINANA_CCG1	max_load	CCGT	NewGen Power Kwinana Pty Ltd
114	Kwinana OCGT 1	all_load	OCGT	IPP

Table C.1 – Dispatch Merit Order

	Station name	Dispatch to:	Type	Participant
115	Kwinana OCGT 2	all_load	OCGT	IPP
116	Kwinana OCGT 3	all_load	OCGT	IPP
117	Muja OCGT 1	all_load	OCGT	IPP
118	Muja OCGT 2	all_load	OCGT	IPP
119	Namarkkon	all_load	OCGT	IPP
120	North Country OCGT 1	all_load	OCGT	IPP
121	North Country OCGT 2	all_load	OCGT	IPP
122	North Metro OCGT 1	all_load	OCGT	IPP
123	North Metro OCGT 2	all_load	OCGT	IPP
124	North Metro OCGT 3	all_load	OCGT	IPP
125	Northern Terminal OCGT 1	all_load	OCGT	IPP
126	Northern Terminal OCGT 2	all_load	OCGT	IPP
127	Northern Terminal OCGT 3	all_load	OCGT	IPP
128	ALINTA_WGP_GT	all_load	OCGT	Alinta Sales Pty Ltd
129	ALINTA_WGP_U2	all_load	OCGT	Alinta Sales Pty Ltd
130	PRK_AG	all_load	OCGT	Goldfields Power Pty Ltd
131	STHRNCRS_EG	all_load	OCGT	Southern Cross Energy
132	Kwinana B - LMS100 U1	all_load	OCGT	Verve
133	Kwinana B - LMS100 U2	all_load	OCGT	Verve
134	KWINANA_GT1	all_load	OCGT	Verve Energy
135	PINJAR_GT11	all_load	OCGT	Verve Energy
136	PINJAR_GT10	all_load	OCGT	Verve Energy
137	PINJAR_GT9	all_load	OCGT	Verve Energy
138	KEMERTON_GT11	all_load	OCGT	Verve Energy
139	KEMERTON_GT12	all_load	OCGT	Verve Energy
140	PINJAR_GT1	all_load	OCGT	Verve Energy
141	PINJAR_GT2	all_load	OCGT	Verve Energy
142	PINJAR_GT3	all_load	OCGT	Verve Energy
143	PINJAR_GT4	all_load	OCGT	Verve Energy
144	PINJAR_GT5	all_load	OCGT	Verve Energy
145	PINJAR_GT7	all_load	OCGT	Verve Energy
146	MUNGARRA_GT1	all_load	CCGT	Verve Energy
147	MUNGARRA_GT2	all_load	CCGT	Verve Energy
148	MUNGARRA_GT3	all_load	CCGT	Verve Energy
149	WEST_KALGOORLIE_GT2	all_load	OCGT	Verve Energy
150	WEST_KALGOORLIE_GT3	all_load	OCGT	Verve Energy
151	GERALDTON_GT1	all_load	OCGT	Verve Energy
152	Joanna Plains Peaking	all_load	Diesel	IPP
153	Muja Diesel 1	all_load	Diesel	IPP
154	Muja Diesel 3	all_load	Diesel	IPP
155	Muja Diesel 4	all_load	Diesel	IPP

Table C.1 – Dispatch Merit Order

	Station name	Dispatch to:	Type	Participant
156	Tesla Diesel Units 1-2	all_load	Diesel	IPP
157	Tesla Diesel Units 3-8	all_load	Diesel	IPP
158	Tesla Diesel Units 9-15	all_load	Diesel	IPP
159	Wild Energy	all_load	Diesel	IPP
160	Energy Response DSM1	all_load	DSM	IPP
161	Energy Response DSM2	all_load	DSM	IPP
162	DSM1	all_load	DSM	IPP
163	DSM2	all_load	DSM	IPP

Appendix D) PLANT PROVIDING LOAD FOLLOWING

ROAM has assumed that the following plant is available in the SWIS to provide load following. Each plant becomes progressively available in each scenario as they are installed (refer to planting scenarios in Table B.1 to Table B.4. Plant are utilised in the priority order as shown (new plant, if available, is favoured).

Order	Plant name	Capacity (MW)		Load following provided (±MW)
		Minimum	Maximum	
1	Kwinana B - LMS100 U1	27	100	37
2	Kwinana B - LMS100 U2	27	100	37
3	PINJAR_GT11	35	123	44
4	PINJAR_GT10	35	116	41
5	PINJAR_GT9	35	116	41
6	PINJAR_GT7	10	38.2	14
7	PINJAR_GT5	10	38.2	14
8	PINJAR_GT4	10	38.2	14
9	PINJAR_GT3	10	38.2	14
10	PINJAR_GT2	10	37.2	14
11	PINJAR_GT1	10	37.2	14
12	MUNGARRA_GT3	10	38.2	14
13	MUNGARRA_GT2	10	37.2	14
14	MUNGARRA_GT1	10	37.2	14

Appendix E) PLANT ONLINE PROVIDING INERTIA

The tables below indicate the amount of each plant online at each time (minimum load, maximum load, and an intermediate load level). These values were calculated based upon the dispatch merit order listed above and the minimum and maximum load levels projected for each scenario. They were used as an input to the system frequency model for determining the required governor response to maintain stable frequencies with increasing fast deviations due to the penetration of intermittent generation.

Note that the total plant online is higher than the load at time of minimum load, because these values include the full capacities of plant that are operating at minimum load. The full capacity of the unit is considered to contribute to its inertia if it is operating (not just the proportion of its capacity that is actually generating at that time).

Table E.1 – Plant online (Scenario 1)															
	Load	Total ⁹³	Coal	CCS ⁹⁴	CCGT	OCGT	Diesel	Geo	Biomass	Wind	Cogen	Solar PV	Solar Thermal	DSM ⁹⁵	Wave
2009-10	Min	2504	1523	0	0	0	0	0	0	191	551	0	0	0	0
	Int	3641	2100	0	561	0	0	0	0	191	551	0	0	0	0
	Max	4249	2100	0	561	608	0	0	0	191	551	0	0	0	0
2012-13	Min	2719	1153	0	0	200	0	0	0	571	551	0	0	0	5
	Int	4420	2100	0	755	200	0	0	0	571	551	0	0	0	5
	Max	5336	2100	0	755	1116	0	0	0	571	551	0	0	0	5
2014-15	Min	2507	423	0	0	200	0	0	0	821	551	0	0	0	5
	Int	5154	2315	0	755	200	0	0	0	821	551	0	0	0	5
	Max	5750	2315	0	755	796	0	0	0	821	551	0	0	0	5
2019-20	Min	2587	215	0	0	200	0	0	30	1021	551	0	0	0	25
	Int	5986	2530	0	1085	200	0	0	30	1021	551	0	0	0	25
	Max	6748	2530	0	1085	962	0	0	30	1021	551	0	0	0	25

⁹³ This includes the full capacities of plant running at minimum load, since the full capacity of the plant is the relevant parameter for the calculation of inertia.

⁹⁴ CCS technology is not included in Scenario 2.

⁹⁵ DSM and Diesel plant are not dispatched at time of maximum load, but are required for system security in case of plant outages.

2024-25	Min	2644	0	0	0	200	0	0	0	1236	551	0	50	0	25
	Int	6653	2530	0	1410	200	0	40	30	1236	551	0	50	0	25
	Max	7593	2530	0	1410	1140	0	40	30	1236	551	0	50	0	25
2029-30	Min	2944	0	0	75	200	0	0	0	1460	551	0	0	0	75
	Int	7664	2530	0	1955	200	0	40	30	1651	551	0	50	0	75
	Max	8279	2530	0	1955	815	0	40	30	1651	551	0	50	0	75

Table E.2 – Plant online (Scenario 2)

	Load	Total ⁹⁶	Coal	CCS ⁹⁷	CCGT	OCGT	Diesel	Geo	Biomass	Wind	Cogen	Solar PV	Solar Thermal	DSM ⁹⁸	Wave
2009-10	Min	2504	1523	0	0	0	0	0	0	191	551	0	0	0	0
	Int	3641	2100	0	561	0	0	0	0	191	551	0	0	0	0
	Max	4403	2100	0	561	762	0	0	0	191	551	0	0	0	0
2012-13	Min	2959	1523	0	237	200	0	0	0	321	551	0	0	0	5
	Int	4054	2100	0	755	200	0	0	0	321	551	0	0	0	5
	Max	5275	2100	0	755	1421	0	0	0	321	551	0	0	0	5
2014-15	Min	3089	1523	0	0	200	0	0	0	571	551	0	0	0	5
	Int	4640	2320	0	755	200	0	0	0	571	551	0	0	0	5
	Max	5804	2320	0	755	1364	0	0	0	571	551	0	0	0	5
2019-20	Min	3287	1523	0	0	200	0	0	70	679	551	0	0	0	25
	Int	5063	2320	0	980	200	0	0	70	679	551	0	0	0	25
	Max	6739	2320	0	980	1876	0	0	70	679	551	0	0	0	25
2024-25	Min	3249	1157	0	0	200	0	0	70	811	551	30	50	0	25
	Int	5981	2535	0	1310	200	0	45	70	811	551	30	50	0	25
	Max	7641	2535	0	1310	1860	0	45	70	811	551	30	50	0	25

⁹⁶ This includes the full capacities of plant running at minimum load, since the full capacity of the plant is the relevant parameter for the calculation of inertia.

⁹⁷ CCS technology is not included in Scenario 2.

⁹⁸ DSM and Diesel plant are not dispatched at time of maximum load, but are required for system security in case of plant outages.

2029-30	Min	3414	946	0	0	200	0	0	70	1011	551	30	100	0	75
	Int	6938	2535	0	1865	200	0	70	70	1011	551	30	100	0	75
	Max	8489	2535	0	1865	1751	0	70	70	1011	551	30	100	0	75

Table E.3 – Plant online (Scenario 3)

	Load	Total ⁹⁹	Coal	CCS ¹⁰⁰	CCGT	OCGT	Diesel	Geo	Biomass	Wind	Cogen	Solar PV	Solar Thermal	DSM ¹⁰¹	Wave
2009-10	Min	2504	1523	0	0	0	0	0	0	191	551	0	0	0	0
	Int	3641	2100	0	561	0	0	0	0	191	551	0	0	0	0
	Max	4249	2100	0	561	608	0	0	0	191	551	0	0	0	0
2012-13	Min	2959	1523	0	237	200	0	0	0	321	551	0	0	0	5
	Int	4054	2100	0	755	200	0	0	0	321	551	0	0	0	5
	Max	5199	2100	0	755	1344	0	0	0	321	551	0	0	0	5
2014-15	Min	2959	1338	0	0	200	0	0	0	626	551	0	0	0	5
	Int	4590	2100	0	865	200	0	5	0	626	551	0	0	0	5
	Max	5631	2100	0	865	1241	0	5	0	626	551	0	0	0	5
2019-20	Min	2897	731	0	0	200	0	0	70	935	551	30	0	0	25
	Int	5535	2100	0	1210	200	0	60	70	935	551	30	0	0	25
	Max	6465	2100	0	1210	1130	0	60	70	935	551	30	0	0	25
2024-25	Min	2852	416	0	0	200	0	0	70	1067	551	30	50	0	75
	Int	6150	2100	0	1545	200	0	70	70	1067	551	30	50	0	75
	Max	7100	2100	0	1545	1150	0	70	70	1067	551	30	50	0	75
2029-30	Min	2830	0	0	0	200	0	0	0	1267	551	30	100	0	175
	Int	7210	2100	0	1990	200	0	220	70	1267	551	30	100	0	175
	Max	7825	2100	0	1990	815	0	220	70	1267	551	30	100	0	175

⁹⁹ This includes the full capacities of plant running at minimum load, since the full capacity of the plant is the relevant parameter for the calculation of inertia.

¹⁰⁰ CCS technology is not included in Scenario 2.

¹⁰¹ DSM and Diesel plant are not dispatched at time of maximum load, but are required for system security in case of plant outages.

Table E.4 – Plant online (Scenario 4)

	Load	Total ¹⁰²	Coal	CCS ¹⁰³	CCGT	OCGT	Diesel	Geo	Biomass	Wind	Cogen	Solar PV	Solar Thermal	DSM ¹⁰⁴	Wave
2009-10	Min	2504	1523	0	0	0	0	0	0	191	551	0	0	0	0
	Int	3641	2100	0	561	0	0	0	0	191	551	0	0	0	0
	Max	4403	2100	0	561	762	0	0	0	191	551	0	0	0	0
2012-13	Min	2959	1523	0	237	200	0	0	0	321	551	0	0	0	5
	Int	4274	2320	0	755	200	0	0	0	321	551	0	0	0	5
	Max	5495	2320	0	755	1421	0	0	0	321	551	0	0	0	5
2014-15	Min	3089	1523	0	0	200	0	0	0	571	551	0	0	0	5
	Int	4640	2320	0	755	200	0	0	0	571	551	0	0	0	5
	Max	6017	2320	0	755	1577	0	0	0	571	551	0	0	0	5
2019-20	Min	3080	1346	0	0	200	0	0	40	679	551	0	0	0	25
	Int	5423	2935	0	755	200	0	0	40	679	551	0	0	0	25
	Max	7326	2935	0	755	2103	0	0	40	679	551	0	0	0	25
2024-25	Min	3130	1038	0	0	200	0	0	70	811	551	30	50	0	25
	Int	6266	3150	0	980	200	0	45	70	811	551	30	50	0	25
	Max	8414	3150	0	1092	2235	0	45	70	811	551	30	50	0	25
2029-30	Min	3275	830	0	0	200	0	0	70	1026	551	30	100	0	75
	Int	7029	3150	0	1315	200	0	120	70	1026	551	30	100	0	75
	Max	9418	3150	0	1315	2589	0	120	70	1026	551	30	100	0	75

¹⁰² This includes the full capacities of plant running at minimum load, since the full capacity of the plant is the relevant parameter for the calculation of inertia.

¹⁰³ CCS technology is not included in Scenario 2.

¹⁰⁴ DSM and Diesel plant are not dispatched at time of maximum load, but are required for system security in case of plant outages.

Appendix F) DISPATCH MODELLING WITH 2-4-C

Forecasting with 2-4-C

2-4-C is ROAM's flagship product, a complete proprietary electricity market forecasting package. It was built to match as closely as possible the operation of the AEMO Market Dispatch Engine (NEMDE) used for real day-to-day dispatch in the NEM. However, it is capable of modelling any electricity network, and is in use to model small systems such as the North-West Interconnected System (NWIS) of Western Australia, and the enormous 4000 bus CALISO system of California.

2-4-C implements the highest level of detail, and bases dispatch decisions on generator bidding patterns and availabilities. The model includes modelling of forced full and partial and planned outages for each generator, including renewable energy generators and inter-regional transmission capabilities and constraints.

ROAM continually monitors real generator bid profiles and operational behaviours, and with this information constructs realistic 'market' bids for all generators. Then any known factors that may influence existing or new generation are taken into account. These might include for example water availability, changes in regulatory measures, or fuel availability. The process of doing this is central to delivering high quality, realistic operational profiles that translate into sound wholesale price forecasts.

Key Parameters used by the Model

Data contained within the **2-4-C** model is a combination of the best information sources within information available in the public domain including:

- All released IMO Statements of Opportunity through to the present, together with half-hourly historical load profiles by region;
- Annual Planning Statements by Network Service Providers;
- Corporate Annual Reports for many market participants (generators, retailers and network service providers), and;
- General reports from market participants.

F.1) MODELLING ASSUMPTIONS

Demand side assumptions

Inclusion of customers

A bulk load consumption facility has been included to represent the cumulative, time-sequential, load consumption profile used in the study.

Demand-side participation

The vast majority of demand in the wholesale market currently operates as a series of aggregated loads for the purposes of schedule and dispatch. Though some individual customers may be responsive to price, the majority of end-consumers are shielded from short-term price fluctuations through retail contracts. Thus, incentives to reduce demand during high-price periods are dissipated.

In this study, several aggregated demand side participants are included, and bid above diesel generation (as the most expensive capacity in the market). This reflects the high cost of demand side participation.

Supply side assumptions (generation assets)

Existing projects

These market forecasts take into account all existing market scheduled generation facilities. In addition, the likely commissioning schedule (beginning typically three months prior to commercial operation) for new generators has been taken into account.

Individual unit capacities and heat rates

Details of unit capacities and heat rates (for thermal plants) have been collated and included on the basis of information available from the public domain.

Unit emissions intensity factors

Emissions Intensity Factors have been collated from public sources and along with heat rates are the basis for determining the uplift in Short Run Marginal Cost (and hence market bids) for each generator under the Carbon Pollution Reduction Scheme.

Forecast station outage parameters

2-4-C utilises independent schedules for each unit of:

- Planned maintenance, and
- Randomised forced outage (both full and partial outage) distribution.

These schedules have been constructed based on information in the public domain and historical generator availabilities - in particular, the following six key parameters are used in the development of outage schedules and are detailed in the table below.

Table F.1 – Generator outage modelling assumptions	
<i>Full Forced Outage Rate:</i>	Proportion of time per year the unit will experience full forced outages.

<i>Partial Forced Outage Rate:</i>	Proportion of time per year the unit will experience partial forced outages.
<i>Number of Full Outages:</i>	The frequency of full outages per year.
<i>Number of Partial Outages:</i>	The frequency of partial outages per year.
<i>Derated Value:</i>	Proportion of the unit's maximum capacity that the unit will be derated by in the event of a partial outage.
<i>Full Maintenance Schedule:</i>	Maintenance schedule of planned outages (each planned outage has a start and end date between which the unit will be unavailable).

Generation commercial data

In the development of the chosen trading strategy for each generator, key commercial data is used, including:

- The intra-regional Marginal Loss Factor (MLF);
- Operations and maintenance cost;
- Fuel cost, which has been computed with reference to:
 - Unit heat rate;
 - Fuel heating value, and;
 - Fuel unit price;
- Emission factors for greenhouse gas production.

Applying a carbon price

The carbon cost for each generator (in \$/MWh) is given by each generator's emissions factor (tCO₂/MWh), multiplied by the cost of emissions permits. Since the electricity market in Australia is not internationally trade exposed, it is anticipated that generators will largely increase their bids by the amount of their respective carbon costs. Hence, the effects of a carbon price was modelled by adding the carbon cost (\$/MWh) to the bids of each generator. Once these uplifts were applied to all bid bands of all generators, the competitive dispatch was recalculated for each half hourly interval.

Solar Photovoltaics modelling

Solar generators were modelled as a Gaussian output that increased to a peak in the middle of the day, with longer hours during the summer. The profile is shown in the figure below. Solar PV generators were bid into the market at \$0, with volumes based upon their unit trace outputs in each half hour period.

Figure F.1 – Example Solar PV Generation Profile (by time of day and day of financial year)

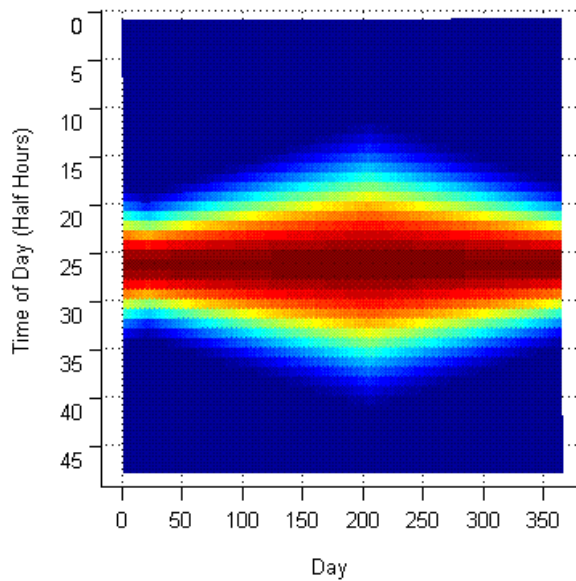
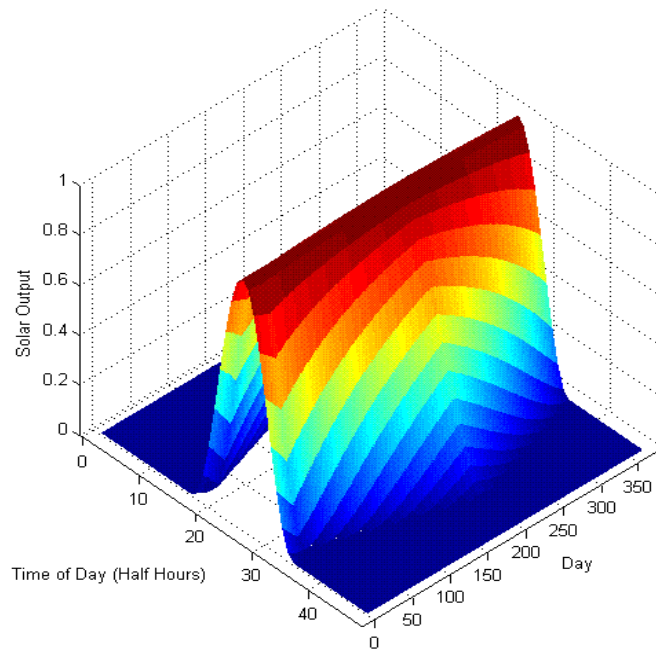

Solar thermal, geothermal and biomass modelling

Solar thermal, geothermal and biomass (bagasse) generators were bid at the following prices:

Table F.2 – Renewable generator bidding

Plant type	Bid price
Biomass / Bagasse	\$12-15 /MWh
Geothermal	\$0 /MWh
Solar Thermal	\$0 /MWh
Solar PV	\$0 /MWh
Wind	\$0 /MWh

Transmission and distribution system assumptions

Losses are modelled commercially in either of two ways, in accordance with existing market rules. Intra-regional losses are modelled by static, but periodically adjusted, marginal loss factors (MLF) in relation to a Regional Reference Node (RRN). These MLF's are published annually (and assumed for new stations).

Market forecasting has been completed on a gross basis. Therefore, the energy profiles assumed for each node have incorporated allowance for (transmission and distribution) losses and generator auxiliary energy.

Assumptions with regard to market externalities

There are numerous externalities that will impact on the operation of the competitive energy market. Several of these are outlined below.

Inflation

All monetary figures provided in this report are listed in equivalent 2009-10 dollars (net of the impact of inflation).

The impact of the Goods and Services Tax

Wholesale market prices are quoted exclusive of the Goods and Services Tax (GST). Hence, projections of the wholesale spot price are provided net of GST.